

Integrating the Healthcare Enterprise



5 **IHE Pathology and Laboratory Medicine (PaLM)
Technical Framework**

10 **Volume 2x
(PaLM TF-2x)
Transactions**

15

20

**Revision 7.0 - Final Text
July 5, 2016**

25

Please verify you have the most recent version of this document, which is published [here](#).

CONTENTS

1	Introduction	6
30	1.1 Introduction to IHE	6
	1.2 Intended Audience	6
	1.3 Overview of Technical Framework Volume 2	6
	1.4 Comment Process.....	7
	1.5 Copyright Licenses	7
35	1.5.1 Copyright of Base Standards	7
	1.6 Trademark.....	8
	1.7 Disclaimer Regarding Patent Rights.....	8
	1.8 History of Document Changes.....	8
2	Conventions	9
40	2.1 Transaction Modeling and Profiling Conventions	9
	2.2 Additional Standards Profiling Conventions used by PaLM TF	9
	2.2.1 Simplified convention for HL7 v2.x message static definition	9
	2.2.2 Simplified convention for HL7 v2.x segment static definition	10
	2.2.3 HL7 v2.x Acknowledgement mode applied in the PaLM TF	10
45	2.2.4 HL7 v2.x Acknowledgement policies applied in the PaLM TF	10
	2.3 Use of Coded Entities and Coding Schemes.....	12
3	Real World Use Cases.....	13
	3.1 Guidelines	13
	3.2 Two Hematology Batteries on a Blood Specimen.....	13
50	3.2.1 Storyboard.....	13
	3.2.2 Interaction Diagram	15
	3.2.3 Messages.....	15
	3.2.3.1 LAB-1 (OP → OF): Message “New order” with one Specimen.....	15
	3.2.3.2 LAB-4 (OF → AM): Message “New order”	16
55	3.2.3.3 LAB-1 (OF → OP): Message “Status changed”	16
	3.2.3.4 LAB-3 (OF->ORT): Message “Order Status Change”	17
	3.2.3.5 LAB-21 (AM→ Analyzer): New AWOS.....	17
	3.2.3.6 LAB-23 (Analyzer → AM): Specimen for AWOS Arrived	18
	3.2.3.7 LAB-23 (Analyzer → AM): Tests Performed.....	18
60	3.2.3.8 LAB-5 (AM->OF): Message “New Results”	18
	3.2.3.9 LAB-1 (OF->OP): Message “Status Changed”	19
	3.2.3.10 LAB-3 (OF->ORT): Message “Status Changed”	19
	3.3 Test on a Series of Specimens: Glucose Tolerance Study	20
	3.3.1 Storyboard.....	20
65	3.3.2 Interaction Diagram	23
	3.3.3 Messages.....	23
	3.3.3.1 LAB-1 (OP → OF): Message “New order” with the first 3 Specimens.....	23
	3.3.3.2 LAB-4 (OF → AM): Message “New order” with the first 2 Specimens	24

	3.3.3.3 LAB-1 (OF → OP): Message “Status changed” with the first 3 Specimens	24
70	3.3.3.4 LAB-3 (OF → ORT): Message first Specimens accepted for an order	25
	3.3.3.5 LAB-5 (AM → OF): Message “New results” for the first 2 Work Orders	25
	3.3.3.6 LAB-1 (OF → OP): Message “Status Changed”	25
	3.3.3.7 LAB-3 (OF → ORT): Message “Status Changed”	26
	3.3.3.8 LAB-1(OP → OF): Message “Change Order/Service Request”	26
75	3.3.3.9 LAB-4 (OF → AM): Message “New order” with the last 2 Specimens	26
	3.3.3.10 LAB-1 (OF → OP): Message “Status changed” with all Specimens	27
	3.3.3.11 LAB-3 (OF → ORT): Message “Status Changed”	27
	3.3.3.12 LAB-5 (AM → OF): “New results” for the last 2 Work Orders	28
	3.3.3.13 LAB-1 (OF → OP): Message “Status Changed”	28
80	3.3.3.14 LAB-3 (OF → ORT): Message “Status Changed”	28
	3.4 Battery with 2 Specimens: Creatinine clearance	29
	3.4.1 Storyboard.....	29
	3.4.2 Interaction Diagram	31
	3.4.3 Messages.....	31
85	3.4.3.1 LAB-1 (OP → OF): Message “New order” with one Specimen.....	31
	3.4.3.2 LAB-4 (OF → AM): Message “New order”	32
	3.4.3.3 LAB-1 (OF → OP): Message “Status Changed”	32
	3.4.3.4 LAB-3 (OF->ORT): Message “Order Status Change”	32
	3.4.3.5 LAB-5 (AM->OF): Message “New Results”	33
90	3.4.3.6 LAB-1 (OF->OP): Message “Status Changed”	33
	3.4.3.7 LAB-3 (OF->ORT): Message “Status Changed”	33
	3.5 Microbiology with Two Specimens and Three Germs Identified	34
	3.5.1 Storyboard.....	34
	3.5.2 Interaction Diagram	36
95	3.5.3 Messages.....	38
	3.5.3.1 LAB-1 (OP → OF): Message “New order” with Two Specimens.....	38
	3.5.3.2 LAB-3 (OF → ORT): Message “Order Status Change”	38
	3.5.3.3 LAB-3 (OF → ORT): Message “Status Changed”	38
	3.5.3.4 LAB-2(OF → OP): Message “Send Order Number”	39
100	3.5.3.5 LAB-3 (OF → ORT): Message “Status Changed”	40
	3.5.3.6 LAB-2(OF → OP): Message “Send Order Number”	41
	3.5.3.7 LAB-3 (OF → ORT): Message “Status Changed”	41
	3.5.3.8 LAB-3 (OF → ORT): Message “Status Changed”	42
	3.6 Rejection of a Specimen	45
105	3.6.1 Storyboard.....	45
	3.6.2 Interaction Diagram	46
	3.6.3 Messages.....	47
	3.6.3.1 LAB-1 (OP -> OF):Message “Create new order”	47
	3.6.3.2 LAB-3 (OF -> ORT/OP) : Acceptance of the order.....	47
110	3.6.3.3 LAB-3 (OF -> ORT/OP) : Rejection of a specimen.....	47
	3.6.3.4 LAB-1 (OP->OF): ‘New Order’ with new specimen for same order group	48

	Appendices.....	49
	Appendix A – HL7 v2.x Common Data Types	50
	A.1 CX – Extended Composite ID with Check Digit	50
115	A.2 EI – Entity Identifier	50
	A.3 EIP – Entity Identifier Pair.....	51
	A.4 HD – Hierarchic Designator.....	52
	Appendix B – <Place Holder>.....	53
	Appendix C – Common HL7 Message Segments	54
120	C.1 MSH – Message Header Segment.....	54
	C.2 NTE – Notes and Comment Segment	58
	C.3 PID – Patient Identification Segment	59
	C.4 PV1 – Patient Visit Segment	61
	C.5 ORC – Common Order Segment.....	61
125	C.6 TQ1 – Timing Quantity Segment	69
	C.7 SPM – Specimen Segment	70
	C.8 SAC – Container Detail Segment.....	85
	C.9 OBX - Observation/Result Segment	87
	C.10 Correlations of Status between ORC, OBR, OBX.....	92
130	C.10.1 Semantics of the Main Status Code Associations	92
	C.10.2 Status Transition Diagrams	93
	C.10.2.1 ORC-5: Order Status.....	93
	C.10.2.2 OBR-25: Order Result Status	94
	C.10.2.3 OBX-11: Observation Result Status	95
135	C.10.3 Relationship between the 3 Status Fields	95
	C.11 Microbiology Reporting Rules	96
	C.11.1 Principle.....	96
	C.11.2 Culture Results	96
	C.11.2.1 Definition	96
140	C.11.2.2 OBX-3 Observation Identifier	96
	C.11.2.3 OBX-4 Observation Sub-ID	97
	C.11.2.4 OBX-5 Observation Value.....	98
	C.11.3 Antimicrobial Sensitivities Results	99
	C.11.3.1 Definition.....	99
145	C.11.3.2 An Example	99
	C.11.3.3 OBR-26 Parent Result	101
	C.11.3.4 OBR-29 Parent.....	101
	C.11.3.5 OBX-3 Observation Identifier	102
	C.11.3.6 OBX-5 Observation Value.....	102
150	C.11.3.7 OBX-8 Abnormal Flags.....	103
	C.12 QAK – Query Acknowledgment Segment.....	103
	C.13 MFI – Master File Identification Segment	104
	C.14 MFE – Master File Entry Segment.....	105
	Appendix D – <Place Holder>.....	107

155	Appendix E – Implementation Notes for POCT1-A DML.....	108
	E.1 IHE usages for DML	108
	E.2 Conversations and Topics.....	108
	E.3 Characteristics of DML Messages.....	112
	E.4 Main Data Types in DML for Transactions LAB-30 and LAB-31	115
160	Glossary	118

1 Introduction

This document, Volume 2x of the IHE Pathology and Laboratory Medicine (PaLM) Technical Framework, defines transactions used in IHE Pathology and Laboratory Medicine profiles.

165 1.1 Introduction to IHE

Integrating the Healthcare Enterprise (IHE) is an international initiative to promote the use of standards to achieve interoperability among health information technology (HIT) systems and effective use of electronic health records (EHRs). IHE provides a forum for care providers, HIT experts and other stakeholders in several clinical and operational domains to reach consensus on standards-based solutions to critical interoperability issues.

170 The primary output of IHE is system implementation guides, called IHE Profiles. IHE publishes each profile through a well-defined process of public review and trial implementation and gathers profiles that have reached final text status into an IHE Technical Framework, of which this volume is a part.

175 For more general information regarding IHE, refer to www.ihe.net. It is strongly recommended that, prior to reading this volume, the reader familiarizes themselves with the concepts defined in the *IHE Technical Frameworks General Introduction*, which is published on [this page](#).

1.2 Intended Audience

The intended audience of IHE Technical Frameworks Volume 2 is:

- 180
- IT departments of healthcare institutions
 - Technical staff of vendors participating in the IHE initiative
 - Experts involved in standards development

1.3 Overview of Technical Framework Volume 2

Volume 2 is comprised of several distinct sections:

- 185
- Section 1 provides background and reference material.
 - Section 2 presents the conventions used in this volume to define the transactions.
 - Section 3 defines Pathology and Laboratory Medicine transactions in detail, specifying the roles for each actor, the standards employed, the information exchanged, and in some cases, implementation options for the transaction.

190 The appendices in Volume 2 provide clarification of technical details of the IHE data model and transactions. A glossary of terms and acronyms used in the IHE Technical Framework, including those from relevant standards, is provided in the IHE Technical Framework General Introduction, which is published on [this page](#). Due to the length of the document, some domains may divide Volume 2 into smaller volumes labeled 2a, 2b, etc. In this case, the Volume 2

195 appendices are gathered in Volume 2x. Code and message samples may also be stored on the
IHE ftp server. In this case, explicit links to the ftp server will be provided in the transaction text.

1.4 Comment Process

IHE International welcomes comments on this document and the IHE initiative. They can be
submitted by sending an email to the co-chairs and secretary of the Pathology and Laboratory
200 Medicine domain committees at palm@ihe.net.

1.5 Copyright Licenses

IHE International hereby grants to each Member Organization, and to any other user of these
documents, an irrevocable, worldwide, perpetual, royalty-free, nontransferable, nonexclusive,
205 non-sublicensable license under its copyrights in any IHE profiles and Technical Framework
documents, as well as any additional copyrighted materials that will be owned by IHE
International and will be made available for use by Member Organizations, to reproduce and
distribute (in any and all print, electronic or other means of reproduction, storage or
transmission) such IHE Technical Documents.

The licenses covered by this Copyright License are only to those copyrights owned or controlled
210 by IHE International itself. If parts of the Technical Framework are included in products that also
include materials owned or controlled by other parties, licenses to use those products are beyond
the scope of this IHE document and would have to be obtained from that other party.

1.5.1 Copyright of Base Standards

IHE technical documents refer to and make use of a number of standards developed and
215 published by several standards development organizations. All rights for their respective base
standards are reserved by these organizations. This agreement does not supersede any copyright
provisions applicable to such base standards.

Health Level Seven, Inc. has granted permission to IHE to reproduce tables from the HL7^{®1}
standard. The HL7 tables in this document are copyrighted by Health Level Seven, Inc. All rights
220 reserved. Material drawn from these documents is credited where used.

The Clinical and Laboratory Standards Institute (CLSI) has granted to IHE the permission to
reproduce tables and figures from the POCT1-A standard. The POCT1-A tables and figures in
the IHE Pathology and Laboratory Medicine Technical Framework are copyrighted by CLSI. All
rights reserved.

225 IHE grants permission to CLSI to reproduce either parts of the Pathology and Laboratory
Medicine Technical Framework.

¹ HL7 is the registered trademark of Health Level Seven International.

1.6 Trademark

IHE[®] and the IHE logo are trademarks of the Healthcare Information Management Systems Society in the United States and trademarks of IHE Europe in the European Community. They may only be used with the written consent of the IHE International Board Operations Committee, which may be given to a Member Organization in broad terms for any use that is consistent with the IHE mission and operating principles.

1.7 Disclaimer Regarding Patent Rights

Attention is called to the possibility that implementation of the specifications in this document may require use of subject matter covered by patent rights. By publication of this document, no position is taken with respect to the existence or validity of any patent rights in connection therewith. IHE International is not responsible for identifying Necessary Patent Claims for which a license may be required, for conducting inquiries into the legal validity or scope of Patents Claims or determining whether any licensing terms or conditions provided in connection with submission of a Letter of Assurance, if any, or in any licensing agreements are reasonable or non-discriminatory. Users of the specifications in this document are expressly advised that determination of the validity of any patent rights, and the risk of infringement of such rights, is entirely their own responsibility. Further information about the IHE International patent disclosure process including links to forms for making disclosures is available at http://www.ihe.net/Patent_Disclosure_Process. Please address questions about the patent disclosure process to the secretary of the IHE International Board: secretary@ihe.net.

1.8 History of Document Changes

This section provides a brief summary of changes and additions to this document.

Date	Document Revision	Change Summary
July 2016	7.0	Adoption of IHE_TF_Template_Vol2_Rev1.0_2014-07-01, Incorporation of the LAW Profile “Final Text”, Update of the LDA Profile by removal of the transactions transferred to LAW. Incorporation of option “labels & containers delivered” for the LBL Profile. Reorganization of Vol 2 content in 4 volumes: <ul style="list-style-type: none">- 2a contains LTW and LDA transactions,- 2b contains LAW transactions and specific appendices,- 2c contains LBL, LPOCT and LCSD transactions- 2x contains common appendices

250

2 Conventions

This document has adopted the following conventions for representing the framework concepts and specifying how the standards upon which the IHE Technical Framework is based shall be applied.

255 2.1 Transaction Modeling and Profiling Conventions

In order to maintain consistent documentation methods, modeling methods for IHE transactions and profiling conventions for frequently used standards are maintained as appendix E “Profiling” in the *IHE Technical Frameworks General Introduction* published on [this page](#).

260 Methods described include the Unified Modeling Language (UML) and standards conventions include DICOM^{®2}, HL7 v2.x, HL7 CDA^{®3}, etc. These conventions are critical to understanding this volume and should be reviewed prior to reading this text.

In addition, this same appendix E provides:

- the network guidelines to be applied for HL7 v2.x messaging (see E.3.2.1) ;
- the message control for HL7 v2.x messaging, and the common definition of the MSH segment (see E.3.2.2) ;
- the acknowledgement modes for HL7 v2.x, and the common definition of the related segments MSA and ERR (see E.3.2.3) ;
- the message granularity, which states that there should be as many messages as trigger events, in other words, one trigger event and one business object per message (see E.3.2.5).
- the empty field convention (“NULL value) for HL7 v2.x messaging (see E.3.2.6) ;

2.2 Additional Standards Profiling Conventions used by PaLM TF

275 This section defines profiling conventions for standards which are not described in the *IHE Technical Frameworks General Introduction*, and which are applied by the transactions of the Pathology and Laboratory Medicine Technical Framework, unless otherwise specified.

2.2.1 Simplified convention for HL7 v2.x message static definition

For readability and brevity reasons, HL7 v2.x message static definitions of the Pathology and Laboratory Medicine Technical Framework may omit the “not supported segments” (segments marked with usage “X”).

² DICOM is the registered trademark of the National Electrical Manufacturers Association for its standards publications relating to digital communications of medical information.

³ CDA is the registered trademark of Health Level Seven International.

280 HL7 v2.x message static definitions of the Pathology and Laboratory Medicine Technical
Framework show in their leftmost column “*Segment*” the optionality and repeatability of
message segments as they appear in the base standard, respectively represented by square
brackets and curly braces. The reader must be aware that the “Usage” and “Card.” Columns on
the right bring further constraints specified by the IHE static definition, which may restrict these
285 base standard optionality and repeatability.

2.2.2 Simplified convention for HL7 v2.x segment static definition

For readability and brevity reasons, HL7 v2.x segment static definitions of the Pathology and
Laboratory Medicine Technical Framework may omit the “optional fields” (fields marked with
usage “O”).

2.2.3 HL7 v2.x Acknowledgement mode applied in the PaLM TF

290 Except otherwise specified, applications implementing transactions of the IHE Pathology and
Laboratory Medicine Technical Framework based on HL7 v2.x messages, use the HL7 original
acknowledgement mode.

An OML message shall be acknowledged by one single ORL message. An OUL or an ORU
295 message shall be acknowledged by one single ACK message.

Nevertheless, these acknowledgements are application-level acknowledgements (i.e., not
transport acknowledgements) and must be generated by the receiving application after it has
parsed the message and processed its content. The receiving application shall automatically
generate the application-level acknowledgement messages without waiting for human approval
300 of the contents of the message that was received.

2.2.4 HL7 v2.x Acknowledgement policies applied in the PaLM TF

From a transactional viewpoint a MLLP (Minimal Lower Layer Protocol) network connection is
unidirectional. Event-triggered messages flow in one direction and acknowledgement messages
related to those event-triggered messages flow in the other direction.

305 The acknowledgement message to an event-triggered message shall be sent *immediately* to the
sender on the same MLLP connection that carried the event-triggered message. The receiver of
an event-triggered message should assume that the sending application is blocking and send an
application-level acknowledgement as soon as possible.

It may take the receiving system a while (seconds, minutes) to acknowledge a message. If the
310 MLLP connection is broken whilst the sending application is still waiting for an
acknowledgement, the sending application shall initiate a new MLLP connection and resend the
message.

The acknowledgement message is an application-level acknowledgement. The application
acknowledgement shall only be created by an application that is able to examine a message at the
315 semantic / business-process level. Intermediate message brokers do not have this capacity and
therefore shall not be used to generate the contents of application acknowledgements.

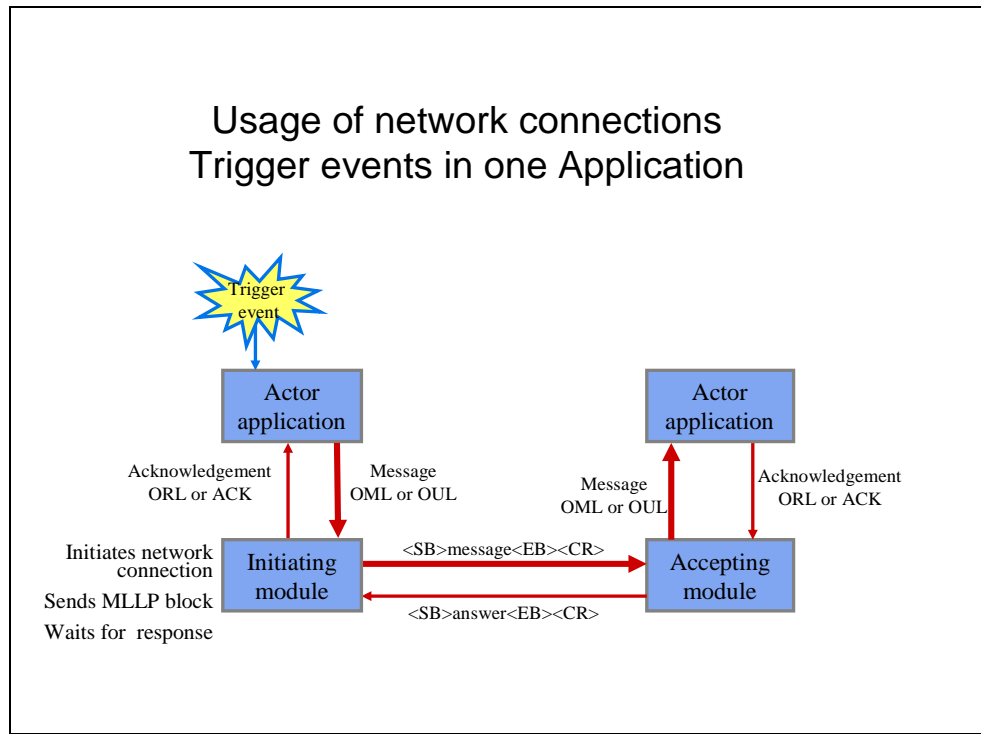

320 Transactions between 2 applications which contain trigger events on both sides (such as LAB-1 for example) require at least two network connections between the actors, one for each direction:

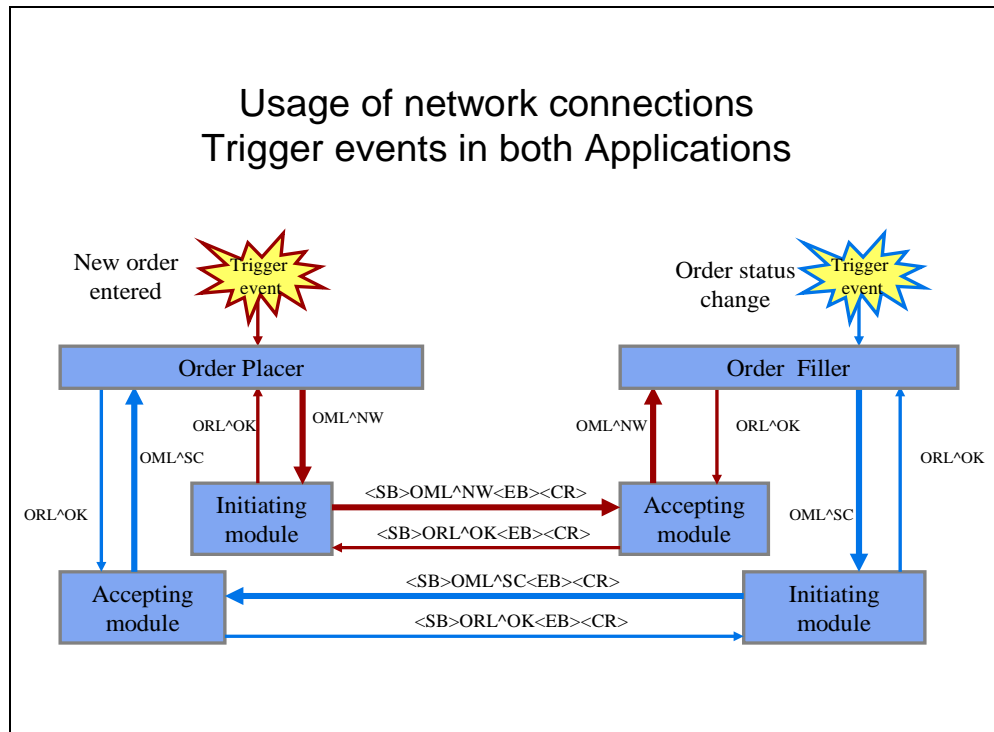

2.3 Use of Coded Entities and Coding Schemes

IHE maintains coding schemes in the *IHE Technical Frameworks General Introduction* Appendix published on [this page](#).

325

3 Real World Use Cases

3.1 Guidelines

Each of the real world use cases in this section are to be considered as a template for handling a category of laboratory testing throughout all the transactions of the Pathology and Laboratory
330 Medicine Technical Framework. Only the major steps and interactions are described.

Each use case is described by a storyboard that describes the complete workflow in chronological order, completed by an interaction diagram, and illustrated by the most significant messages of this workflow.

The message descriptions are abbreviated, to focus on the main points of interest.

335 For brevity, only some of the application acknowledgements are shown.

The actors' names are abbreviated with their initials (OP, OF, AM, ORT). These abbreviations are also used in the MSH-3 (sending application) and MSH-5 (receiving application) fields.

All use cases assume that the placer order is related to a placer group number (ORC-4).

All tests are identified in OBX segments by their LOINC code when available.

340 Colors point out key information in the messages.

3.2 Two Hematology Batteries on a Blood Specimen

3.2.1 Storyboard

This example corresponds to the use case described in Volume 1 as “Externally placed order with specimens unidentified or to be collected by the laboratory”. The specimen is not identified
345 by the ordering care unit.

Dr. Physician orders two batteries of tests on the same specimen: blood count and differential blood count.

Human actors and organizations participating to the process:

Assigning authority:	Abbeville Hospital
350 Placer:	Urology department
Filler:	Cytology laboratory
Ordering facility:	Urology
Patient:	John III, Patient hospital identifier: 6543210, Patient visit number: 999888, class = inpatient
355 Orderer:	Dr. Uro
Placer order enterer:	Janet Nurse

Specimen collector: John Collect
Technician: Marc Techos
Clinical expert: Jane Cyto

360

ID numbers used by the workflow:

ID number	Value	Assigned by
Patient hospital ID	6543210	Admission office (ADT)
Patient visit number	9998888	Admission office (ADT)
Care unit order group	555	Urology department (OP)
Care unit order (1st battery)	9876543	Urology department (OP)
Care unit order (2nd battery)	9876544	Urology department (OP)
Laboratory order (1st battery) idem for work order	456	Cytology laboratory (OF)
Laboratory order (2nd battery) idem for work order	457	Cytology laboratory (OF)
Work Order Step Code (1st battery)	456	Cytology laboratory (AM)
Work Order Step Code (2nd battery)	457	Cytology laboratory (AM)
Specimen	456_1	Cytology laboratory (OF)

365

LAB-1 interaction: The Care Unit collects a specimen related to an order for a blood count and a differential count, and sends the specimen to the chemistry laboratory. The Order Placer sends a message “new order” (NW) accompanying the specimen, to let the laboratory start the testing.

370

LAB-4, LAB-1 and LAB-3 interactions: The laboratory checks the specimen and schedules the work. An identifier is assigned to the specimen by the Order Filler and the corresponding identification label is printed out. The Order Filler sends a unique work order to the Automation Manager. The Order Filler notifies both Order Placer and Order Result Tracker of the scheduled work.

LAB-5, LAB-1 and LAB-3 interactions: After technical validation by a laboratory technician (Marc Techos), the Automation Manager sends back all the observations to the Order Filler.

LAB-1 and LAB-3 interactions: After clinical validation, the Order Filler notifies the results to the Order Result Tracker, and notifies the status change to the Order Placer.

375 **3.2.2 Interaction Diagram**

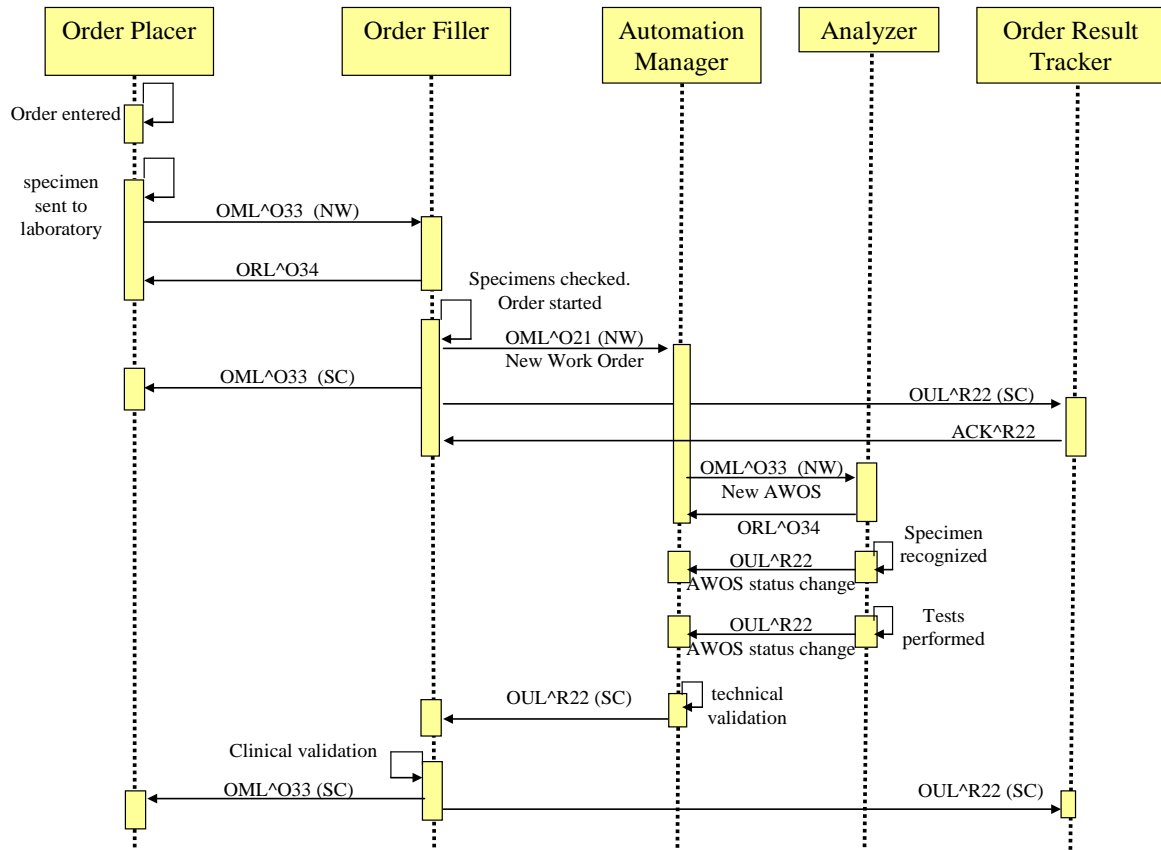

3.2.3 Messages

3.2.3.1 LAB-1 (OP → OF): Message “New order” with one Specimen

380 A new placer order sent to the Order Filler:

```

MSH|^~\&|OP|Urology|OF|Cytology|200310060820||OML^O33^OML_O33|001|T|2.5|||USA||EN
PID|1||6543210^^Abbeville Hospital^PI||ILL^JOHN^^^^L||19810101|M
PV1|1|I|||||9998888
SPM|1||BLD|||||P|||||200310060735|||||1
385 ORC|NW|9876543^Urology|555^Urology
|||200310060710^NURSE^JANET|||||Urology^^^^^FI^^UR01
TQ1|1|||||R
OBR|1|9876543^Urology||85027^Hemogram and platelet count, automated^C4|
|||^COLLECT^JOHN|||^URO^^^^DR
390 ORC|NW|9876544^Urology|555^Urology
|||200310060710^NURSE^JANET|||||Urology^^^^^FI^^UR01
TQ1|1|||||R
OBR|1|9876544^Urology||85009^Differential WBC Count, buffy coat^C4|
|||^COLLECT^JOHN|||^URO^^^^DR
    
```

395

The related acknowledgement message isn't shown.

3.2.3.2 LAB-4 (OF → AM): Message “New order”

A new work order is sent to the Automation Manager:

400 MSH|^~\&|OF|Cytology|AM|Automation|200310060825||OML^O33^OML_O33|101|T|2.5|||USA|EN
PID|1||6543210^^^Abbeville Hospital^PI||ILL^JOHN^^^^L||19810101|M
PV1|1|I|||||9998888
SPM|1|456_1^Cytology|BLD|||||P|||||200310060735|200310060821|||||1
405 ORC|NW||555^Urology||||200310060710|^NURSE^JANET|||||||Urology^^^^^FI^^^UR01
TQ1|1|||||R
OBR|1|456^Cytology||85027^Hemogram and platelet count, automated^C4|
|||^COLLECT^JOHN|||^URO^^^^DR
ORC|NW||555^Urology||||200310060710|^NURSE^JANET|||||||Urology^^^^^FI^^^UR01
TQ1|1|||||R
410 OBR|1|457^Cytology||85009^Differential WBC Count, buffy coat^C4|
|||^COLLECT^JOHN|||^URO^^^^DR

Acknowledgement sent by the Automation Manager:

415 MSH|^~\&|AM|Automation|OF|Cytology|200310060826||ORL^O34^ORL_O34|301|T|2.5|||USA|EN
MSA|AA|101
PID|1||6543210^^^Abbeville Hospital^PI||ILL^JOHN^^^^L||19810101|M
SPM|1|456_1^Cytology|BLD|||||P|||||200310060735|200310060821|||||1
420 ORC|OK||555^Urology|SC||||200310060710|^NURSE^JANET|||||||
Urology^^^^^FI^^^UR01
TQ1|1|||||R
OBR|1|456^Cytology||85027^Hemogram and platelet count, automated^C4|
|||^COLLECT^JOHN|S|||^URO^^^^DR
ORC|OK||555^Urology|SC||||200310060710|^NURSE^JANET|||||||
425 Urology^^^^^FI^^^UR01
TQ1|1|||||R
OBR|1|457^Cytology||85009^Differential WBC Count, buffy coat^C4|
|||^COLLECT^JOHN|S|||^URO^^^^DR

430 3.2.3.3 LAB-1 (OF → OP): Message “Status changed”

The placer order has been assigned a filler order number, the specimen is available and identified by the laboratory:

435 MSH|^~\&|OF|Cytology|OP|Urology|200310060825||OML^O33^OML_O33|108|T|2.5|||USA|EN
PID|1||6543210^^^Abbeville Hospital^PI||ILL^JOHN^^^^L||19810101|M
PV1|1|I|||||9998888
SPM|1|456_1^Cytology|BLD|||||P|||||200310060735|200310060821|Y|||||1
ORC|SC|9876543^Urology||555^Urology|IP||||200310060710|^NURSE^JANET|||||||
Urology^^^^^FI^^^UR01
TQ1|1|||||R
440 OBR|1|9876543^Urology|456^Cytology|85027^Hemogram and platelet count, automated^C4|
|||^COLLECT^JOHN|P|||||^URO^^^^DR|||||I

```
ORC | SC | 9876544^Urology | 555^Urology | IP | ||| 200310060710 | ^NURSE^JANET | |||||  
Urology^^^^^^FI^^^UR01  
TQ1 | 1 | ||||| R  
445 OBR | 1 | 9876544^Urology | 457^Cytology | 85009^Differential WBC Count, buffy coat^C4 |  
||| | ^COLLECT^JOHN | P | ||| | ^URO^^^DR | ||||| I
```

The related acknowledgement message isn't shown.

450 3.2.3.4 LAB-3 (OF->ORT): Message "Order Status Change"

The Order Result Tracker is informed that a new order is being performed:

```
MSH | ^~\& | OF | Cytology | ORT | 200310060825 | OUL^R22^OUL_R22 | 122 | T | 2.5 | ||| | USA | | EN  
PID | 1 | 6543210^^^Abbeville Hospital^PI | ILL^JOHN^^^^^L | 19810101 | M  
PV1 | 1 | I | ||||| 9998888  
455 SPM | 1 | 456_1^Cytology | BLD | ||||| P | ||||| 200310060735 | 200310060821 | | Y | ||||| 1  
OBR | 1 | 9876543^Urology | 456^Cytology | 85027^Hemogram and platelet count, automated^C4 |  
||| | ^COLLECT^JOHN | P | ||| | ^URO^^^DR | ||||| I  
ORC | SC | 9876543^Urology | 555^Urology | IP | ||| 200310060710 | ^NURSE^JANET | |||||  
Urology^^^^^^FI^^^UR01  
460 TQ1 | 1 | ||||| R  
OBR | 2 | 9876544^Urology | 457^Cytology | 85009^Differential WBC Count, buffy coat^C4 |  
||| | ^COLLECT^JOHN | P | ||| | ^URO^^^DR | ||||| I  
ORC | SC | 9876544^Urology | 555^Urology | IP | ||| 200310060710 | ^NURSE^JANET | |||||  
465 Urology^^^^^^FI^^^UR01  
TQ1 | 1 | ||||| R
```

Acknowledgement sent by the Order Results Tracker:

```
470 MSH | ^~\& | ORT | OF | Cytology | 200310060826 | ACK^R22^ACK | 401 | T | 2.5 | ||| | USA | | EN  
MSA | AA | 122
```

3.2.3.5 LAB-21 (AM-> Analyzer): New AWOS

```
475 MSH | ^~\& | AM | Cytology | LD | Cytology | 200506121348 | OML^O33^OML_O33 | 001 | T | 2.5 | ||| | USA | | EN  
PID | 1 | 6543210^^^Abbeville Hospital^PI | ILL^JOHN^^^^^L | 19810101 | M  
PV1 | 1 | I | ||||| 9998888  
SPM | 1 | 456_1 | BLD | ||||| P | ||||| 200506121330 | ||||| 1  
ORC | NW | 9876543^Urology | ||||| 200506121315 | 66622^NURSE^JANET | ||||| | Urology  
TQ1 | ||||| R  
480 OBR | 9876543 | 85027^Hemogram and platelet count, automated^C4 | ||||| | 14788^URO  
ORC | NW | 9876544^Urology | ||||| 200506121315 | 66622^NURSE^JANET | ||||| | Urology  
TQ1 | ||||| R  
OBR | 9876544 | 85009^Differential WBC count, buffy coat^C4 | ||||| | 14788^URO
```

Acknowledgement sent by the Analyzer:

```
485 MSH | ^~\& | LD | Cytology | AM | Cytology | 200506121349 | ORL^O34^ORL_O34 | 101 | T | 2.5 | ||| | USA | | EN  
MSA | AA | 001  
PID | 1 | 6543210^^^Abbeville Hospital^PI | ILL^JOHN^^^^^L | 19810101 | M  
PV1 | 1 | I | ||||| 9998888  
SPM | 1 | 456_1 | BLD
```

490 ORC OK 9876543^Urology|||||200506121349
OBR 9876543||85027^Hemogram and platelet count, automated^C4
ORC OK 9876544^Urology|||||200506121349
OBR 9876544||85009^Differential WBC count, buffy coat^C4

3.2.3.6 LAB-23 (Analyzer → AM): Specimen for AWOS Arrived

495 MSH ^~\&|LD|Cytology|AM|Cytology|200506121400||OUL^R22^OUL_R22|102|T|2.5|||||USA|EN
PID 1||6543210^^^Abbeville Hospital^PI||ILL^JOHN^^^^^L||19810101|M
PV1 1|I|||||||9998888
SPM 1|456_1|BLD
OBR 9876543||85027^Hemogram and platelet count, automated^C4|||||||I
500 ORC SC 9876543^Urology|||||200506121400
OBR 9876544||85009^Differential WBC count, buffy coat^C4|||||||I

Acknowledgement not shown.

3.2.3.7 LAB-23 (Analyzer → AM): Tests Performed

505 MSH ^~\&|LD|Cytology|AM|Cytology|200506121410||OUL^R22^OUL_R22|102|T|2.5|||||USA|EN
PID 1||6543210^^^Abbeville Hospital^PI||ILL^JOHN^^^^^L||19810101|M
PV1 1|I|||||||9998888
SPM 1|456_1|BLD
OBR 9876543||85027^Hemogram and platelet count, automated^C4|||||||R
510 ORC SC 9876543^Urology|||||200506121410
OBX 1|NM|11156-7^LEUKOCYTES^LN||8.2|10*3/mm3||||R||200506121410
OBX 2|NM|11273-0^ERYTHROCYTES^LN||4.08|10*3/mm3||||R||200506121410
OBX 3|NM|20509-6^HEMOGLOBIN^LN||13.4|10*3/mm3||||R||200506121410
OBX 4|NM|20570-8^HEMATOCRIT^LN||39.7|10*3/mm3||||R||200506121410
515 OBX 5|NM|30428-7^MVC^LN||97|10*3/mm3||||R||200506121410
OBX 6|NM|28539-5^MCH^LN||33.0|10*3/mm3||||R||200506121410
OBX 7|NM|28540-3^MCHC^LN||33.8|10*3/mm3||||R||200506121410
OBX 8|NM|11125-2^PLATELETS^LN||220|10*3/mm3||||R||200506121410
OBR 9876544||85009^Differential WBC count, buffy coat^C4|||||||R
520 ORC SC 9876544^Urology|||||200506121410
OBX 1|NM|23761-0^NEUTROPHILS/100 LEUKOCYTES^LN||72|%||||R||200506121410
OBX 2|NM|26450-7^EOSINOPHILS/100 LEUKOCYTES ^LN||2|%||||R||200506121410
OBX 3|NM|26478-8^LYMPHOCYTES/100 LEUKOCYTES ^LN||20|%||||R||200506121410
OBX 4|NM|26485-3^MONOCYTES/100 LEUKOCYTES ^LN||6|%||||R||200506121410
525 OBX 5|NM|30180-4^BASOPHILS/100 LEUKOCYTES ^LN||0|%||||R||200506121410

3.2.3.8 LAB-5 (AM->OF): Message “New Results”

The Automation Manager sends the final results for the work order:

530 MSH ^~\&|AM|Automation|OF|Urology|200310060900||OUL^R22^OUL_R22|308|T|2.5|||||USA|EN
PID 1||6543210^^^Abbeville Hospital^PI||ILL^JOHN^^^^^L||19810101|M
PV1 1|I|||||||9998888
SPM 1|456_1^Cytology|BLD|||||P|||||200310060735|200310060821|Y|||||1
OBR 1|456^Cytology||85027^Hemogram and platelet count, automated^C4|
|||^COLLECT^JOHN|P|||||^URO^^^^DR|
535 |||^200310060832||F|||||^TECHOS&MARC^200310060833
ORC SC||CM||200310060710|^NURSE^JANET|||||||Urology^^^^^FI^^^UR01

540 OBX|1|NM|11156-7^LEUKOCYTES^LN||8.2|10*3/mm3|4-10|N||F|||200310060830
 OBX|2|NM|11273-0^ERYTHROCYTES^LN||4.08|10*6/mm3|10-12|N||F|||200310060830
 OBX|3|NM|20509-6^HEMOGLOBIN^LN||13.4|g/dL|11.5-14.5|N||F|||200310060830
 OBX|4|NM|20570-8^HEMATOCRIT^LN||39.7|%|37-47|N||F|||200310060830
 OBX|5|NM|30428-7^MCV^LN||97|fL|80-95|N||F|||200310060830
 OBX|6|NM|28539-5^MCH^LN||33.0|pg|27-32|N||F|||200310060830
 OBX|7|NM|28540-3^MCHC^LN||33.8|%|30-36|N||F|||200310060830
 OBX|8|NM|11125-2^PLATELETS^LN||220|10*9/L|150-400|N||F|||200310060830
 545 OBR|2|457^Cytology||85009^Differential WBC Count, buffy coat^C4|
 |||^COLLECT^JOHN|P|||||^URO^^^^DR
 |||^200310060832||F|||||^&TECHOS&MARC^200310060833
 ORC|SC|||CM|||200310060710|^NURSE^JANET|||||Urology^^^^^FI^^UR01
 550 OBX|1|NM|23761-0^NEUTROPHILS/100 LEUKOCYTES^LN||72|%|N||F|||200310060830
 OBX|2|NM|26450-7^EOSINOPHILS/100 LEUKOCYTES^LN||2|%|N||F|||200310060830
 OBX|3|NM|26478-8^LYMPHOCYTES/100 LEUKOCYTES^LN||20|%|N||F|||200310060830
 OBX|4|NM|26485-3^MONOCYTES/100 LEUKOCYTES^LN||6|%|N||F|||200310060830
 OBX|5|NM|30180-4^BASOPHILS/100 LEUKOCYTES^LN||0|%|N||F|||200310060830

555 The related acknowledgement message isn't shown.

3.2.3.9 LAB-1 (OF->OP): Message "Status Changed"

The clinical expert has performed the clinical validation at 09h29. The order is completed:

560 MSH|^~\&|OF|Urology|OP|Urology|200310060930||OML^O33^OML_O33|181|T|2.5|||USA||EN
 PID|1||6543210^^Abbeville Hospital^PI||ILL^JOHN^^^^L||19810101|M
 PV1|1|I|||||9998888
 SPM|1|456_1^Cytology||BLD|||||P|||||200310060735|200310060821||Y|||||1
 ORC|SC|9876543^Urology||555^Urology|CM|||200310060710|^NURSE^JANET|||||Urology^^^^^FI^^UR01
 565 TQ1|1|||||R
 OBR|1|9876543^Urology|456^Cytology|85027^Hemogram and platelet count, automated^C4|
 |||^COLLECT^JOHN|P|||||^URO^^^^DR|||||F|||||^&CYTO&JANE^200310060929
 ORC|SC|9876544^Urology||555^Urology|CM|||200310060710|^NURSE^JANET|||||Urology^^^^^FI^^UR01
 570 TQ1|1|||||R
 OBR|1|9876544^Urology|457^Cytology|85009^Differential WBC Count, buffy coat^C4|
 |||^COLLECT^JOHN|P|||||^URO^^^^DR|||||F|||||^&CYTO&JANE^200310060929

The related acknowledgement message isn't shown.

575

3.2.3.10 LAB-3 (OF->ORT): Message "Status Changed"

The clinical expert has performed the clinical validation at 09h29. The order is completed. The results are final:

580 MSH|^~\&|OF|Cytology|ORT||200310060931||OUL^R22^OUL_R22|182|T|2.5|||USA||EN
 PID|1||6543210^^Abbeville Hospital^PI||ILL^JOHN^^^^L||19810101|M
 PV1|1|I|||||9998888
 SPM|1|456_1^Cytology||BLD|||||P|||||200310060735|200310060821||Y|||||1
 OBR|1|9876543^Urology|456^Cytology|85027^Hemogram and platelet count, automated^C4|

```
585 | | | | ^COLLECT^JOHN|P| | | | ^URO^^^^DR|
| | | | | 200310060929| | | | | &CYTO&JANE^200310060929
ORC | SC | 9876543^Urology | 555^Urology | CM | | | | 200310060710 | ^NURSE^JANET | | | | | | | | | |
Urology^^^^^^FI^^UR01
TQ1 | 1 | | | | | | | R
OBX | 1 | NM | 11156-7^LEUKOCYTES^LN | 8.2 | 10*3/mm3 | 4-10 | N | | | | F | | | 200310060830
590 | OBX | 2 | NM | 11273-0^ERYTHROCYTES^LN | 4.08 | 10*6/mm3 | 10-12 | N | | | | F | | | 200310060830
OBX | 3 | NM | 20509-6^HEMOGLOBIN^LN | 13.4 | g/dL | 11.5-14.5 | N | | | | F | | | 200310060830
OBX | 4 | NM | 20570-8^HEMATOCRIT^LN | 39.7 | % | 37-47 | N | | | | F | | | 200310060830
OBX | 5 | NM | 30428-7^MCV^LN | 97 | fL | 80-95 | N | | | | F | | | 200310060830
OBX | 6 | NM | 28539-5^MCH^LN | 33.0 | pg | 27-32 | N | | | | F | | | 200310060830
595 | OBX | 7 | NM | 28540-3^MCHC^LN | 33.8 | % | 30-36 | N | | | | F | | | 200310060830
OBX | 8 | NM | 11125-2^PLATELETS^LN | 220 | 10*9/L | 150-400 | N | | | | F | | | 200310060830
OBR | 2 | 9876544^Urology | 457^Cytology | 85009^Differential WBC Count, buffy coat^C4 |
| | | | ^COLLECT^JOHN|P| | | | ^URO^^^^DR|
| | | | | 200310060929| | | | | &CYTO&JANE^200310060929
600 | ORC | SC | 9876544^Urology | 555^Urology | CM | | | | 200310060710 | ^NURSE^JANET | | | | | | | | | |
Urology^^^^^^FI^^UR01
TQ1 | 1 | | | | | | | R
OBX | 1 | NM | 23761-0^NEUTROPHILS/100 LEUKOCYTES^LN | 72 | % | N | | | | F | | | 200310060830
OBX | 2 | NM | 26450-7^EOSINOPHILS/100 LEUKOCYTES^LN | 2 | % | N | | | | F | | | 200310060830
605 | OBX | 3 | NM | 26478-8^LYMPHOCYTES/100 LEUKOCYTES^LN | 20 | % | N | | | | F | | | 200310060830
OBX | 4 | NM | 26485-3^MONOCYTES/100 LEUKOCYTES^LN | 6 | % | N | | | | F | | | 200310060830
OBX | 5 | NM | 30180-4^BASOPHILS/100 LEUKOCYTES^LN | 0 | % | N | | | | F | | | 200310060830
```

The related acknowledgement message isn't shown.

610

3.3 Test on a Series of Specimens: Glucose Tolerance Study

3.3.1 Storyboard

This use case is in the context given by the first general use case presented in Volume 1 “3.1.1: Externally placed order with identified specimens”. The ordering care unit thus identifies the specimens.

615

Dr. Physician orders one battery and provides a series of specimen collected at different times. The battery consists of one single test: glucose concentration on blood serum, repeated on a number of specimens, to be performed by the chemistry laboratory. The order is assumed to be part of a group of placer orders identified by the placer group number ‘666’.

620

Glucose tolerance is ordered as a single battery requesting for glucose test on an unspecified number of blood serum drawn at different intervals, after initial glucose ingestion”. The SPM segments in the order message indicate the number of specimens, which can vary. The result consists of all the observation performed on each related individual specimen. All specimens produce results, except one unfortunately broken.

625

Human actors and organizations participating to the process:

Assigning authority: Memphis Hosp.

Placer: Entero-gastric department
Filler: Chemistry laboratory
Ordering facility: Entero-gastric
630 Patient: Adam Everyman Jr., account number: 12345 (check-digit 5 modulo 10),
class = outpatient.
Orderer: Dr. Physician, phone number 821, ID number in the hospital 222222
Placer order enterer: Nancy Nurse, ID number 222221
Specimen collector: M. Bleeder, ID number 1234
635 Technician: Suzy Technician, ID number 333333
Clinical expert: Jane Chemistry-Expert, ID number 444444

ID numbers used by the workflow:

ID number	Value	Assigned by
Patient ID	12345	Admission office (ADT)
Care unit order	12345678	Entero-gastric department (OP)
Care unit order group	666	Entero-gastric department (OP)
1 st specimen	123456781	Entero-gastric department (OP)
2 nd specimen	123456782	Entero-gastric department (OP)
3 rd specimen	123456783	Entero-gastric department (OP)
4 th specimen	123456784	Entero-gastric department (OP)
5 th specimen	123456785	Entero-gastric department (OP)
Laboratory order	555	Chemistry laboratory (OF)
1 st work order	555_1	Chemistry laboratory (OF)
2 nd work order	555_2	Chemistry laboratory (OF)
3 rd work order	555_3	Chemistry laboratory (OF)
4 th work order	555_4	Chemistry laboratory (OF)

640 **LAB-1 interaction:** The Care Unit collects the first three specimens related to an order for
glucose tolerance, with the high priority ‘ASAP’, and sends these specimens to the chemistry
laboratory. The Order Placer sends a message “new order” (NW) accompanying the first three
specimens, to let the laboratory start the testing. OBR-11 “Specimen action code” is valued to
645 “P” (pending specimen) indicating that some specimens for this order are still pending (i.e., not
yet collected). The order placer provides an observation reporting the initial quantity of sugar
absorbed by the patient.

LAB-4, LAB-1 and LAB-3 interactions: The laboratory checks the specimens and schedules
the work. The Order Filler sends the first work orders to the Automation Manager. The Order

650 Filler notifies both Order Placer and Order Result Tracker of the scheduled work, notifying that the third specimen being broken, won't produce any observation. SPM-20 (specimen availability) = 'N' and SPM-21 (specimen reject reason) = 'RB' (broken container). Since this is a timing series, the Order Placer won't replace this specimen. There will simply be a missing point in the final observation graph.

655 **LAB-5, LAB-1 and LAB-3 interactions:** After technical validation, the Automation Manager sends back the first two observations to the Order Filler. Given that the order priority is "ASAP", the Order Filler notifies these partial results to the Order Result Tracker, and notifies the status change to the Order Placer, without waiting for the clinical validation.

660 **LAB-1 interaction:** Later on, as the two last specimens are sent to the laboratory, the Order Placer sends an additional message for that order, with the order control "change order request" (XO). This message contains the complete list of specimens. OBR-11 "Specimen action code" is valued to "S", indicating that the specimen collection is complete, and that the laboratory can achieve its work.

665 **LAB-4, LAB-1 and LAB-3 interactions:** The laboratory checks the last specimens. The Order Filler sends the last work orders to the Automation Manager. The Order Filler notifies both Order Placer and Order Result Tracker with the progress of the order.

LAB-5 interaction: After technical validation, the Automation Manager sends the last results to the Order Filler.

LAB-1 and LAB-3 interactions: After clinical validation, the Order Filler notifies the final results to the Order Result Tracker, and notifies the status change to the Order Placer.

670 **3.3.2 Interaction Diagram**

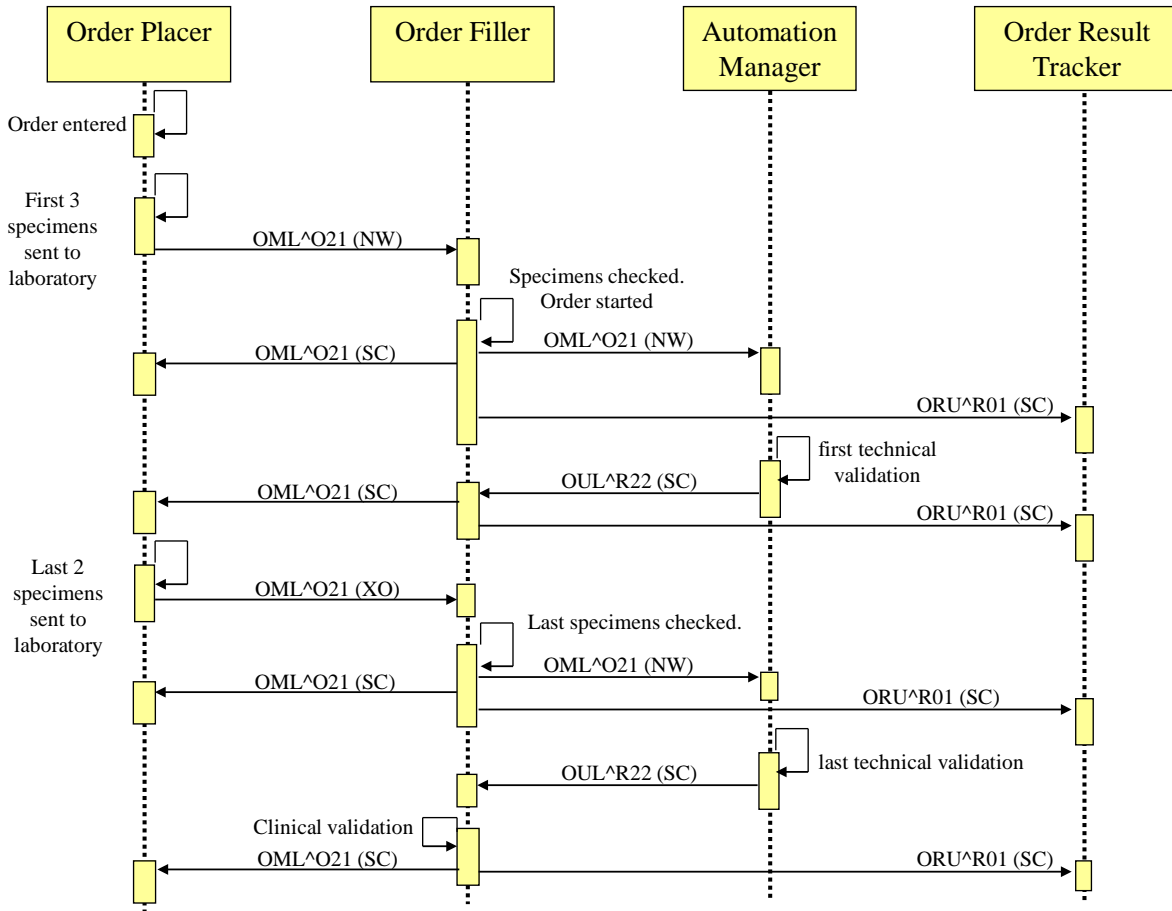

3.3.3 Messages

3.3.3.1 LAB-1 (OP → OF): Message “New order” with the first 3 Specimens

A new placer order sent to the Order Filler: Priority “ASAP” for this placer order. One observation provided by the placer. Three first specimens collected. The other specimens are pending.

675

```

MSH|^~\&|OP|Entero-gastric|OF|Chemistry|200309060820||OML^O21^OML_O21|
msgOP123|T|2.5|123| ||USA|EN
680 PID|1||12345^5^M10^Memphis_Hosp^PI|EVERYMAN^ADAM^JR^^L|19800101|M
PV1|1|O|Ward|||||||12345
ORC|NW|12345678^gastric|666^gastric|||||200309060710|222221^NURSE^NANCY|||||||Ent
ero-gastric^^^^^FI^^EG02
685 TQ1|||||||A
OBR||12345678^gastric||82951^Glucose Tolerance Test^C4|||||1234^BLEEDER|
P|||||222222^PHYSICIAN^^^DR|821
OBX|1|NM|GLUCOSE|75|g||||F|||200309060735
    
```

690 SPM|1|123456781^gastric||SER|||||P|||||200309060735|||||||1
SPM|2|123456782^gastric||SER|||||P|||||200309060755|||||||1
SPM|3|123456783^gastric||SER|||||P|||||200309060815|||||||1

The related acknowledgement message isn't shown.

3.3.3.2 LAB-4 (OF → AM): Message “New order” with the first 2 Specimens

695 Two new work orders sent to the Automation Manager: Priority ASAP. One observation provided.

700 MSH|^~\&|OF|Chemistry|AM|Automation|200309060825||OML^O21^OML_O21|msgOF101|T|2.5|123||
||USA||EN
PID|1||12345^5^M10^Memphis_Hosp^PI||EVERYMAN^ADAM^^JR^^L|19800101|M
PV1|1|O|Ward|||||||12345
ORC|NW||666^gastric|||200309060824|222221^NURSE^NANCY|||||||
Entero-gastric^^^^^FI^^EG02
TQ1|||||||A
OBR||555_1^chemistry||GLUC^GLUCOSE^L|||||1234^BLEEDER|S|||||22222^PHYSICIAN^^^DR|82
1
705 SPM|1|123456781^gastric||SER|||||P|||||200309060735|200309060821|||||||1
ORC|NW||666^gastric|||200309060710|222221^NURSE^NANCY|||||||
Entero-gastric^^^^^FI^^EG02
TQ1|||||||A
OBR||555_2^chemistry||GLUC^GLUCOSE^L|||||1234^BLEEDER|S|||||
710 22222^PHYSICIAN^^^DR|821
SPM|1|123456782^gastric||SER|||||P|||||200309060755|200309060821|||||||1

The related acknowledgement message isn't shown.

3.3.3.3 LAB-1 (OF → OP): Message “Status changed” with the first 3 Specimens

715 The placer order has been assigned a filler order number. One specimen is rejected:

720 MSH|^~\&|OF|Chemistry|OP|Entero-gastric|200309060825||OML^O21^OML_O21|msgOF102|
T|2.5|123|||USA||EN
PID|1||12345^5^M10^Memphis_Hosp^PI||EVERYMAN^ADAM^^JR^^L|19800101|M
PV1|1|O|Ward|||||||12345
ORC|SC|12345678^gastric||666^gastric|IP|||200309060824|222221^NURSE^NANCY|||||||
Entero-gastric^^^^^FI^^EG02
TQ1|||||||A
OBR||12345678^gastric|555^chemistry|82951^Glucose Tolerance Test^C4|||||
1234^BLEEDER|P|||||22222^PHYSICIAN^^^DR|821|||||||I
725 SPM|1|123456781^gastric||SER|||||P|||||200309060735|200309060821|Y|||||1
SPM|2|123456782^gastric||SER|||||P|||||200309060755|200309060821|Y|||||1
SPM|3|123456783^gastric||SER|||||P|||||200309060815|200309060821|N|RB|||||1

The related acknowledgement message isn't shown.

730

3.3.3.4 LAB-3 (OF → ORT): Message first Specimens accepted for an order

The Order Result Tracker is informed that a new order is in process: The observation related to the 3rd specimen (unavailable) is canceled.

```
735 MSH|^~\&|OF|Chemistry|ORT||200309060825||ORU^R01^ORU_R01|msgOF103|T|2.5|123|||USA|EN
PID|1||12345^5^M10^Memphis_Hosp^PI||EVERYMAN^ADAM^^JR^^L|19800101|M
PV1|1|O|Ward|||||||12345
ORC|SC|12345678^gastric||666^gastric|IP|||200309060824|222221^NURSE^NANCY
|||Enterogastric^^^^^^FI^^EG02
740 OBR||12345678^gastric|555^chemistry|82951^Glucose Tolerance Test^C4|||||
1234^BLEEDER|P||||222222^PHYSICIAN^^^DR|821|||||I
TQ1|||||A
OBX|1|NM|GLUCOSE||75|g||||F||200309060735
OBX|2|NM|30264-6^GLUCOSE 40M POST DOSE GLUCOSE^LN|||||X
745 SPM|1|123456781^gastric||SER||||P||||200309060735|200309060821||Y||||1
SPM|2|123456782^gastric||SER||||P||||200309060755|200309060821||Y||||1
SPM|3|123456783^gastric||SER||||P||||200309060815|200309060821||N|RB||||1
```

The related acknowledgement message isn't shown.

3.3.3.5 LAB-5 (AM → OF): Message “New results” for the first 2 Work Orders

750 The Automation Manager sends the two final results for the 2 work orders, technically validated by Suzy TECHNICIAN at 8h33:

```
MSH|^~\&|AM|Automation|OF|Chemistry|200309060833||OUL^R22^OUL_R22|msgAM1|T|2.5|123|||
USA|EN
755 PID|1||12345^5^M10^Memphis_Hosp^PI||EVERYMAN^ADAM^^JR^^L|19800101|M
SPM|1|123456781^gastric||SER||||P||||200309060735|200309060821|||||1
OBR||555_1^chemistry||GLUC^GLUCOSE^L||||1234^BLEEDER
|S||||222222^PHYSICIAN^^^DR|821||||200309060832||F|||||
333333&TECHNICIAN&Suzy&&&&MEMPHIS HOSPITAL^200309060833
760 OBX|1|NM|14749-6^GLUCOSE^LN||4200|umol/l||N||F||200309060830
SPM|2|123456782^gastric||SER||||P||||200309060755|200309060821|||||1
OBR||555_2^chemistry||GLUC^GLUCOSE^L||||1234^BLEEDER
|S||||222222^PHYSICIAN^^^DR|821||||200309060832||F|||||
333333&TECHNICIAN&Suzy&&&&MEMPHIS HOSPITAL^200309060833
OBX|1|NM|14749-6^GLUCOSE^LN||6000|umol/l||N||F||200309060832
```

765 The related acknowledgement message isn't shown.

3.3.3.6 LAB-1 (OF → OP): Message “Status Changed”

Some results are available, not clinically validated (i.e., not verified)

```
770 MSH|^~\&|OF|Chemistry|OP|Enterogastric|200309060834||OML^O21^OML_O21|msgOF104|
T|2.5|123|||USA|EN
PID|1||12345^5^M10^Memphis_Hosp^PI||EVERYMAN^ADAM^^JR^^L|19800101|M
PV1|1|O|Ward||||||12345
ORC|SC|12345678^gastric||666^gastric|A|||200309060834|222221^NURSE^NANCY|
|||Enterogastric^^^^^^FI^^EG02
775 TQ1|||||A
OBR||12345678^gastric|555^chemistry|82951^Glucose Tolerance
Test^C4||||1234^BLEEDER|P||||222222^PHYSICIAN^^^DR|821|||||R
SPM|1|123456781^gastric||SER||||P||||200309060735|200309060821||Y||||1
SPM|2|123456782^gastric||SER||||P||||200309060755|200309060821||Y||||1
```

SPM|3|123456783^gastric ||SER|||||P|||||200309060815|200309060821||N|RB|||||1

780 The related acknowledgement message isn't shown.

3.3.3.7 LAB-3 (OF → ORT): Message “Status Changed”

The two first results are sent, not clinically validated (i.e., not verified):

785 MSH|^~\&|OF|Chemistry|ORT||200309060825||ORU^R01^ORU_R01|msgOF105|T|2.5|123|||USA|EN
PID|1||12345^5^M10^Memphis_Hosp^PI||EVERYMAN^ADAM^^JR^^L|19800101|M
PVL|1|O|Ward|||||||12345
ORC|SC|12345678^gastric||666^gastric|A|||||200309060834|222221^NURSE^NANCY|
|||||Enterogastric^^^^FI^^EG02
790 OBR||12345678^gastric|^chemistry|82951^Glucose Tolerance
Test^C4|||||1234^BLEEDER|P|||||22222^PHYSICIAN^^^DR|821||||||R
TQ1|||||||A
OBX|1|NM|GLUCOSE||75|g|||||F|||200309060735
OBX|2|NM|14996-3^GLUCOSE PRE 75 G GLUCOSE PO^LN||4200|umol/l|4000-6100|N||
R||200309060755
795 OBX|3|NM|30263-8^GLUCOSE 20M POST DOSE GLUCOSE^LN||6000|umol/l|<7800|N||
R||200309060755
OBX|4|NM|30264-6^GLUCOSE 40M POST DOSE GLUCOSE^LN|||X
SPM|1|123456781^gastric ||SER|||||P|||||200309060735|200309060821||Y|||||1
SPM|2|123456782^gastric ||SER|||||P|||||200309060755|200309060821||Y|||||1
800 SPM|3|123456783^gastric ||SER|||||P|||||200309060815|200309060821||N|RB^Broken
container|||||1

The related acknowledgement message isn't shown.

3.3.3.8 LAB-1(OP → OF): Message “Change Order/Service Request”

The last 2 specimens have been collected and are sent to the laboratory:

805 MSH|^~\&|OP|Enterogastric|OF|Chemistry|200309060900||OML^O21^OML_O21|msgOP124|
T|2.5|123|||USA|EN
PID|1||12345^5^M10^Memphis_Hosp^PI||EVERYMAN^ADAM^^JR^^L|19800101|M
PVL|1|O|Ward|||||||12345
810 ORC|XO|12345678^gastric||666^gastric||||||200309060855|222221^NURSE^NANCY|
|||||Enterogastric^^^^FI^^EG02
TQ1|||||||A
OBR||12345678^gastric||82951^Glucose Tolerance Test^C4|||||1234^BLEEDER|S|||||
22222^PHYSICIAN^^^DR|821
815 OBX|1|NM|GLUCOSE||75|g|||||F|||200309060735
SPM|1|123456781^gastric ||SER|||||P|||||200309060735|1
SPM|2|123456782^gastric ||SER|||||P|||||200309060755|1
SPM|3|123456783^gastric ||SER|||||P|||||200309060815|1
SPM|4|123456784^gastric ||SER|||||P|||||200309060835|1
SPM|5|123456785^gastric ||SER|||||P|||||200309060855|1

820 The related acknowledgement message isn't shown.

3.3.3.9 LAB-4 (OF → AM): Message “New order” with the last 2 Specimens

Two new work orders sent to the Automation Manager:

825 MSH|^~\&|OF|Chemistry|AM|Automation|200309060905||OML^O21^OML_O21|msgOF106|T|2.5|123|
||USA|EN
PID|1||12345^5^M10^Memphis_Hosp^PI||EVERYMAN^ADAM^^JR^^L|19800101|M

```

PV1|1|O|Ward|||||||12345
ORC|NW|||666^gastric|||200309060904|222221^NURSE^NANCY|||||||
Entero-gastric^^^^^^FI^^EG02
TQ1|||||||A
830 OBR||555_4^chemistry||GLUC^GLUCOSE^L|||1234^BLEEDER|
S|||222222^PHYSICIAN^^^DR|821
SPM|1|123456784^gastric||SER|||||P|||||200309060835|200309060902|||||1
ORC|NW|||666^gastric|||200309060904|222221^NURSE^NANCY|||||||
Entero-gastric^^^^^^FI^^EG02
835 TQ1|||||||A
OBR||555_5^chemistry||GLUC^GLUCOSE^L|||1234^BLEEDER|S|||||
222222^PHYSICIAN^^^DR|821
SPM|1|123456785^gastric||SER|||||P|||||200309060855|200309060902|||||1
    
```

The related acknowledgement message isn't shown.

840 3.3.3.10 LAB-1 (OF → OP): Message “Status changed” with all Specimens

All the specimens have been checked by the laboratory staff.

```

MSH|^~\&|OF|Chemistry|OP|Entero-gastric|200309060905||OML^O21^OML_O21|msgOF107|
T|2.5|123|||USA||EN
PID|1||12345^5^M10^Memphis_Hosp^PI||EVERYMAN^ADAM^^JR^^L|19800101|M
845 PV1|1|O|Ward|||||||12345
ORC|SC|12345678^gastric||666^gastric|A|||200309060904|222221^NURSE^NANCY|
|||||Entero-gastric^^^^^^FI^^EG02
TQ1|||||||A
OBR||12345678^gastric|555^chemistry|82951^Glucose Tolerance test^C4|||||
850 1234^BLEEDER|P|||||222222^PHYSICIAN^^^DR|821|||||R
SPM|1|123456781^gastric||SER|||||P|||||200309060735|200309060821|Y|||||1
SPM|2|123456782^gastric||SER|||||P|||||200309060755|200309060821|Y|||||1
SPM|3|123456783^gastric||SER|||||P|||||200309060815|200309060821|N|RB|||||1
SPM|4|123456784^gastric||SER|||||P|||||200309060835|200309060902|Y|||||1
855 SPM|5|123456785^gastric||SER|||||P|||||200309060855|200309060902|Y|||||1
    
```

The related acknowledgement message isn't shown.

3.3.3.11 LAB-3 (OF → ORT): Message “Status Changed”

The last two specimens have been received. All the work is scheduled:

```

MSH|^~\&|OF|Chemistry|ORT||200309060905||ORU^R01^ORU_R01|msgOF108|T|2.5|123|||USA||EN
860 PID|1||12345^5^M10^Memphis_Hosp^PI||EVERYMAN^ADAM^^JR^^L|19800101|M
PV1|1|O|Ward|||||||12345
ORC|SC|12345678^gastric||666^gastric|A|||200309060904|222221^NURSE^NANCY|||||||En
tero-gastric^^^^^^FI^^EG02
OBR||12345678^gastric|555^chemistry|82951^Glucose Tolerance Test^C4|||||
865 1234^BLEEDER|S|||||222222^PHYSICIAN^^^DR|821|||||R
TQ1|||||||A
OBX|1|NM|GLUCOSE||75|g|||||F|||200309060735
OBX|2|NM|14996-3^GLUCOSE PRE 75 G GLUCOSE PO^LN||4200|umol/l|4000-6100|N|||
R||200309060735
870 OBX|3|NM|30263-8^GLUCOSE 20M POST DOSE GLUCOSE^LN||6000|umol/l|<7800|N|||
R||200309060755
OBX|4|NM|30264-6^GLUCOSE 40M POST DOSE GLUCOSE^LN|||X
SPM|1|123456781^gastric||SER|||||P|||||200309060735|200309060821|Y|||||1
SPM|2|123456782^gastric||SER|||||P|||||200309060755|200309060821|Y|||||1
875 SPM|3|123456783^gastric||SER|||||P|||||200309060815|200309060821|N|RB^Broken
container|||||1
    
```

```
SPM|4|123456784^gastric ||SER|||||P|||||200309060835|200309060902||Y|||||1  
SPM|5|123456785^gastric ||SER|||||P|||||200309060855|200309060902||Y|||||1
```

The related acknowledgement message isn't shown.

880 3.3.3.12 LAB-5 (AM → OF): “New results” for the last 2 Work Orders

The Automation Manager sends the two final results for the 2 work orders, technically validated by Suzy TECHNICIAN at 9h12.

```
MSH|^~\&|AM|Automation|OF|Chemistry |200309060912||OUL^R22^OUL_R22|msgAM2|  
T|2.5|123|||USA||EN  
885 PID|1||12345^5^M10^Memphis_Hosp^PI||EVERYMAN^ADAM^^JR^^L|19800101|M  
SPM|1|123456784^gastric ||SER|||||P|||||200309060835|200309060902|||1  
OBR||555_4^chemistry||30266-1^GLUCOSE 1.6H POST DOSE GLUCOSE^LN|||1234^BLEEDER|  
S|||222222^PHYSICIAN^^^DR|821|||200309060911||F|||||  
890 333333&TECHNICIAN&Suzy&&&&MEMPHIS HOSPITAL^200309060912  
OBX|1|NM|14749-6^GLUCOSE^LN||7200|umol/l||N||F|||200309060910  
SPM|2|123456785^gastric ||SER|||||P|||||200309060855|200309060902|||1  
OBR||555_5^chemistry||GLUC^GLUCOSE^L|||1234^BLEEDER|S|||  
222222^PHYSICIAN^^^DR|821|||200309060911||F|||||  
895 333333&TECHNICIAN&Suzy&&&&MEMPHIS HOSPITAL^200309060912  
OBX|1|NM|14749-6^GLUCOSE^LN||7100|umol/l||N||F|||200309060911
```

The related acknowledgement message isn't shown.

3.3.3.13 LAB-1 (OF → OP): Message “Status Changed”

Jane CHEMISTRY-EXPERT has performed the clinical validation at 9h29. The order is completed.

```
900 MSH|^~\&|OF|Chemistry|OP|Entero-gastric|200309060930||OML^O21^OML_O21|msgOF109|  
T|2.5|123|||USA||EN  
PID|1||12345^5^M10^Memphis_Hosp^PI||EVERYMAN^ADAM^^JR^^L|19800101|M  
PV1|1|O|Ward|||12345  
905 ORC|SC|12345678^gastric||666^gastric|CM|||200309060929|222221^NURSE^NANCY|||E  
ntero-gastric^^^^^FI^^EG02  
TQ1|||A  
OBR||12345678^gastric||555^chemistry||82951^Glucose Tolerance Test^C4|||1  
1234^BLEEDER|S|||222222^PHYSICIAN^^^DR|821|||200309060929||F|||||  
444444&CHEMISTRY-EXPERT&Jane&&&&MEMPHIS HOSPITAL^200309060929  
910 SPM|1|123456781^gastric ||SER|||||P|||||200309060735|200309060821||Y|||||1  
SPM|2|123456782^gastric ||SER|||||P|||||200309060755|200309060821||Y|||||1  
SPM|3|123456783^gastric ||SER|||||P|||||200309060815|200309060821||N|RB|||1  
SPM|4|123456784^gastric ||SER|||||P|||||200309060835|200309060902||Y|||||1  
SPM|5|123456785^gastric ||SER|||||P|||||200309060855|200309060902||Y|||||1
```

915

The related acknowledgement message isn't shown.

3.3.3.14 LAB-3 (OF → ORT): Message “Status Changed”

Jane CHEMISTRY-EXPERT has performed the clinical validation at 9h29. The order is completed. The results are final.

```
920 MSH|^~\&|OF|Chemistry|ORT||200309060930||ORU^R01^ORU_R01|msgOF110|T|2.5|123|||USA||EN  
PID|1||12345^5^M10^Memphis_Hosp^PI||EVERYMAN^ADAM^^JR^^L|19800101|M  
PV1|1|O|Ward|||12345
```

ORC | SC | 12345678^gastric | 666^gastric | CM | | | | 200309060929 | 222221^NURSE^NANCY | | | | | | | | | | E
ntero-gastric^^^^^FI^^EG02

925 OBR | 12345678^gastric | 555^chemistry | 82951^Glucose Tolerance Test^C4 | | | | | |
1234^BLEEDER | S | | | | 222222^PHYSICIAN^^^DR | 821 | | | | 200309060929 | | F | | | | | | | |
444444&CHEMISTRY-EXPERT&Jane&&&&&MEMPHIS HOSPITAL^200309060929
TQ1 | | | | | | | | | | A

930 OBX | 1 | NM | GLUCOSE | 75 | g | | | | | F | | | | 200309060735
OBX | 2 | NM | 14996-3^GLUCOSE PRE 75 G GLUCOSE PO^LN | 4200 | umol/l | 4000-6100 | N | | |
F | | | | 200309060735
OBX | 3 | NM | 30263-8^GLUCOSE 20M POST DOSE GLUCOSE^LN | 6000 | umol/l | <7800 | N | | |
F | | | | 200309060755
OBX | 4 | NM | 30264-6^GLUCOSE 40M POST DOSE GLUCOSE^LN | | | | | | | | X
935 OBX | 5 | NM | 14756-1^GLUCOSE 1H POST DOSE GLUCOSE^LN | 7200 | umol/l | <7800 | N | | |
F | | | | 200309060835
OBX | 6 | NM | 30265-3^GLUCOSE 1.3H POST DOSE GLUCOSE^LN | 7100 | umol/l | <7800 | N | | |
F | | | | 200309060855

940 SPM | 1 | 123456781^gastric | | SER | | | | | | P | | | | | 200309060735 | 200309060821 | | Y | | | | | 1
SPM | 2 | 123456782^gastric | | SER | | | | | | P | | | | | 200309060755 | 200309060821 | | Y | | | | | 1
SPM | 3 | 123456783^gastric | | SER | | | | | | P | | | | | 200309060815 | 200309060821 | | N | RB^Broken
container | | | | | 1
SPM | 4 | 123456784^gastric | | SER | | | | | | P | | | | | 200309060835 | 200309060902 | | Y | | | | | 1
SPM | 5 | 123456785^gastric | | SER | | | | | | P | | | | | 200309060855 | 200309060902 | | Y | | | | | 1

945 The related acknowledgement message isn't shown.

3.4 Battery with 2 Specimens: Creatinine clearance

3.4.1 Storyboard

This example corresponds to the use case described in Volume 1 as “Externally placed order with specimens unidentified or to be collected by the laboratory”. The specimens are not identified by the ordering care unit.

950

Dr. Nephro orders one battery of one test: a creatinine clearance.

The battery consists of a procedure applied on two specimen type, serum and 24-hour urine. At the end of the 24-hour urine collection process, the specimen collector measures the collected urine volume, records the duration of collection, takes a urine sample from the 24 hours collection and draws a serum sample from the patient.

955

The order is assumed to be part of a group of placer orders identified by the placer group number ‘777’.

Human actors and organizations participating to the process:

Assigning authority: Abbeville Hospital

960 Placer: Nephrology department

Filler: Chemistry laboratory

Ordering facility: Nephrology

Patient: John Ill, Patient hospital identifier: 6543210, Patient visit number: 999888, class = inpatient

965 Orderer: Dr. Nephro
Placer order enterer: Janet Nurse
Specimen collector: John Collect
Technician: Marc Techos
Clinical expert: Jane Chemistry

970

ID numbers used by the workflow:

ID number	Value	Assigned by
Patient hospital ID	6543210	Admission office (ADT)
Patient visit number	9998888	Admission office (ADT)
Care unit order group	777	Nephrology department (OP)
Care unit order	9876543	Nephrology department (OP)
Laboratory order (1 st battery) idem for work order	654	Chemistry laboratory (OF)
Specimen Serum	654_1	Chemistry laboratory (OF)
Specimen Urine	654_2	Chemistry laboratory (OF)

975 **LAB-1 interaction:** The Care Unit processes the specimen collection related to an order for a creatinine clearance, and sends the notified or measured values and the specimens to the chemistry laboratory. The Order Placer sends a message “new order” (NW) accompanying the specimen, to let the laboratory start the testing.

980 **LAB-4, LAB-1 and LAB-3 interactions:** The laboratory checks the specimens and schedules the work. An identifier is assigned to the specimens by the Order Filler and the corresponding identification labels are printed out. The Order Filler sends a unique work order to the Automation Manager. The Order Filler notifies both Order Placer and Order Result Tracker of the scheduled work.

LAB-5, LAB-1 and LAB-3 interactions: After technical validation by a laboratory technician (Marc Techos), the Automation Manager sends back all the observations to the Order Filler.

985 **LAB-1 and LAB-3 interactions:** After clinical validation, the Order Filler notifies the results to the Order Result Tracker, and notifies the status change to the Order Placer. The last interaction in transaction LAB-3 shows a negative acknowledgement and a repetition of the message followed by the final positive acknowledgement.

3.4.2 Interaction Diagram

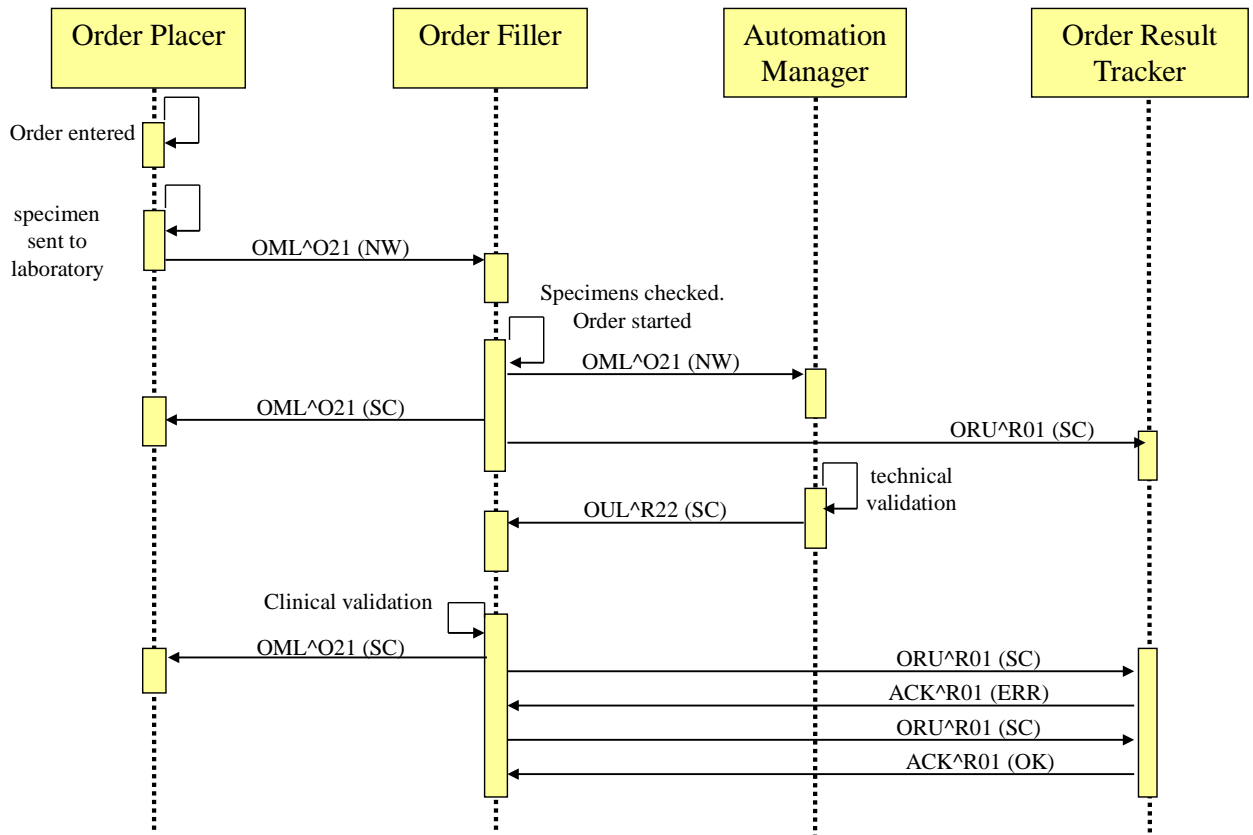

990 3.4.3 Messages

3.4.3.1 LAB-1 (OP → OF): Message “New order” with one Specimen

A new placer order sent to the Order Filler:

```
MSH|^~\&|OP|Nephrology|OF|Chemistry|200310060820||OML^O21^OML_O21|001|T|2.5|||USA||E
```

```
995 PID|1||6543210^^^Abbeville Hospital^PI||ILL^JOHN^^^^^L||19810101|M
```

```
PV1|1|I|||||||9998888
```

```
ORC|NW|9876543^Nephro|777^Nephro|||200310060710|^NURSE^JANET|||
```

```
Nephrology^^^^^FI^^^NE03
```

```
TQ1|1| |||||R
```

```
1000 OBR|1|9876543^Nephro|82575^Creatinine clearance^C4|||^COLLECT^JOHN|S|||
^NEPHRO^^^^DR
```

```
OBX|1|NM|13362-9^URINE COLLECTION DURATION^LN||24|hr|||F||200309060735
```

1005 OBX|2|NM|19153-6^URINE SPECIMEN VOLUME^LN|2500|ml|||F||200309060735
SPM|1||SER||||P|||200310060735|||1
SPM|2||UR||||P|||200310060735|||1
ORC|NW||777^Nephro||200310060710|^NURSE^JANET||||Nephrology^^^^^FI^^NE03
OBR|2|98765432^Nephro|11502-2^LABORATORY REPORT.TOTAL^LN|

The related acknowledgement message isn't shown.

3.4.3.2 LAB-4 (OF → AM): Message “New order”

1010 A new work order is sent to the Automation Manager:
MSH|^~\&|OF|Chemistry|AM|Automation|200310060825||OML^O21^OML_O21|011|T|2.5|||USA||E
N
PID|1||6543210^^Abbeville Hospital^PI||ILL^JOHN^^^^L||19810101|M
PV1|1|I|||||9998888
1015 ORC|NW||777^Nephro||200310060710|^NURSE^JANET||||Nephrology^^^^^FI^^NE03
TQ1|1|||||R
OBR|1|654^chemistry|82575^Creatinine clearance^C4|||^COLLECT^JOHN|S|||^NEPHRO^^^^DR
1020 OBX|1|NM|13362-9^URINE COLLECTION DURATION^LN|24|hr|||F||200309060735
OBX|2|NM|19153-6^URINE SPECIMEN VOLUME^LN|2500|ml|||F||200309060735
SPM|1|654_1^chemistry|SER||||P|||200310060735|200310060821|||1
SPM|2|654_2^chemistry|UR||||P|||200310060735|200310060821|||1

The related acknowledgement message isn't shown.

3.4.3.3 LAB-1 (OF → OP): Message “Status Changed”

The placer order has been assigned a filler order number, the specimen is available and identified by the laboratory:

MSH|^~\&|OF|Chemistry|OP|Nephrology|200310060825||OML^O21^OML_O21|012|T|2.5|||USA||E
N
1030 PID|1||6543210^^Abbeville Hospital^PI||ILL^JOHN^^^^L||19810101|M
PV1|1|I|||||9998888
ORC|SC|9876543^Nephro|777^Nephro|IP|||200310060710|^NURSE^JANET||||Nephrology^^^^^FI^^NE03
TQ1|1|||||R
1035 OBR|1|9876543^Nephro|654^chemistry|82575^Creatinine clearance^C4|||^COLLECT^JOHN|P|||^NEPHRO^^^^DR|||I
SPM|1|654_1^chemistry|SER||||P|||200310060735|200310060821||Y|||1
SPM|2|654_2^chemistry|UR||||P|||200310060735|200310060821||Y|||1

The related acknowledgement message isn't shown.

3.4.3.4 LAB-3 (OF->ORT): Message “Order Status Change”

The Order Result Tracker is informed that a new order is being processed:

MSH|^~\&|OF|Chemistry|ORT||200310060825||ORU^R01^ORU_R01|013|T|2.5|||USA||EN
PID|1||6543210^^Abbeville Hospital^PI||ILL^JOHN^^^^L||19810101|M
PV1|1|I|||||9998888
1045 ORC|SC|9876543^Nephro|777^Nephro|IP|||200310060710|^NURSE^JANET||||Nephrology^^^^^FI^^NE03
OBR|1|9876543^Nephro|654^chemistry|82575^Creatinine clearance^C4|||^COLLECT^JOHN|P|||^NEPHRO^^^^DR|||I
TQ1|1|||||R
1050 SPM|1|654_1^chemistry|SER||||P|||200310060735|200310060821||Y|||1

```
SPM|2|654_2^chemistry|UR|||||P|||||200310060735|200310060821|Y|||||1  
OBX|1|NM|13362-9^URINE COLLECTION DURATION^LN|24|hr|||||F|||200309060735  
OBX|2|NM|19153-6^URINE SPECIMEN VOLUME^LN|2500|ml|||||F|||200309060735
```

The related acknowledgement message isn't shown.

1055 3.4.3.5 LAB-5 (AM->OF): Message "New Results"

The Automation Manager sends the final results for the work order:

```
MSH|^~\&|AM|Automation|OF|Nephrology|200310060900||OUL^R22^OUL_R22|3331|T|2.5|||||  
USA|EN  
PID|1||6543210^^^Abbeville Hospital^PI||ILL^JOHN^^^^^L||19810101|M  
1060 PV1|1|I|||||9998888  
SPM|1|654_1^chemistry|SER|||||P|||||200310060735|200310060821|Y|||||1  
OBX|1|654^chemistry||82575^Creatinine clearance^C4|||||^COLLECT^JOHN|  
P|||||^NEPHRO^^^^DR|||||200310060832||F|||||&TECHOS&MARC^200310060833  
1065 OBX|2|NM|15045-8^SERUM CREATININE^LN|93|umol/l|50-100|N||F|||200310060830  
SPM|1|654_2^chemistry|UR|||||P|||||200310060735|200310060821|Y|||||1  
OBX|1|654^chemistry||82575^Creatinine clearance^C4|||||^COLLECT^JOHN|  
P|||||^NEPHRO^^^^DR|||||200310060832||F|||||&TECHOS&MARC^200310060833  
OBX|1|NM|14684-5^24H URINE CREATININE ^LN|7.06|mmol|8-16 (/24hr)|L||F|||  
200310060830  
1070 OBX|2|NM|2164-2^CREATININE CLEARANCE^LN|52.7|ml/min|88-174|L||S|F|||200310060830
```

The related acknowledgement message isn't shown.

3.4.3.6 LAB-1 (OF->OP): Message "Status Changed"

The clinical expert has performed the clinical validation at 09h29. The order is completed:

```
MSH|^~\&|OF|Nephrology|OP|Nephrology|200310060930||OML^O21^OML_O21|014|T|2.5|||||  
1075 USA|EN  
PID|1||6543210^^^Abbeville Hospital^PI||ILL^JOHN^^^^^L||19810101|M  
PV1|1|I|||||9998888  
ORC|SC|9876543^Nephro||777^Nephro|CM|||||200310060710|^NURSE^JANET|Nephrology^^^^^^FI^^NE03  
1080 TQ1|1|I|||||R  
OBX|1|9876543^Nephro|654^chemistry||82575^Creatinine clearance^C4|  
|||||^COLLECT^JOHN|P|||||^NEPHRO^^^^DR|||||F|||||&CYTO&JANE^200310060929  
SPM|1|654_1^chemistry|SER|||||P|||||200310060735|200310060821|Y|||||1  
SPM|2|654_2^chemistry|UR|||||P|||||200310060735|200310060821|Y|||||1
```

1085 The related acknowledgement message isn't shown.

3.4.3.7 LAB-3 (OF->ORT): Message "Status Changed"

The clinical expert has performed the clinical validation at 09h29. The order is completed. The results are final:

```
MSH|^~\&|OF|Chemistry|ORT||200310060931||ORU^R01^ORU_R01|015|T|2.5|||||USA|EN  
1090 PID|1||6543210^^^Abbeville Hospital^PI||ILL^JOHN^^^^^L||19810101|M  
PV1|1|I|||||9998888  
ORC|SC|9876543^Nephro||777^Nephro|CM|||||200310060710|^NURSE^JANET|Nephrology^^^^^^FI^^NE03  
1095 OBX|1|9876543^Nephro|654^chemistry||82575^Creatinine clearance^C4|||||^COLLECT^JOHN|  
|P|||||^NEPHRO^^^^DR|||||200310060929||F|||||&CYTO&JANE^200310060929  
TQ1|1|I|||||R  
OBX|1|NM|2164-2^CREATININE CLEARANCE^LN|52.7|ml/min|88-174|L||S|F|||200310060735  
OBX|2|NM|15045-8^SERUM CREATININE^LN|93|umol/l|50-100|N||F|||200310060735
```

```

1100 OBX|3|NM|14684-5^24H URINE CREATININE^LN||7.06|mmol|8-16 (/24hr)|L||F||| 200310060830
SPM|1|654_1^chemistry|SER|||||P|||||200310060735|200310060821||Y|||||1
SPM|2|654_2^chemistry|UR|||||P|||||200310060735|200310060821||Y|||||1
OBX|1|NM|13362-9^URINE COLLECTION DURATION^LN||24|hr||||F|||200309060735
OBX|2|NM|19153-6^URINE SPECIMEN VOLUME^LN||2400|ml||||F|||200309060735
1105 ORC|SC||777^Nephro||||200805191100
OBR|2|98765432^Nephro|6542^chemistry|11502-2^LABORATORY
REPORT.TOTAL^LN|||||F
OBX|1|RP|11502-2^LABORATORY REPORT.TOTAL^LN||file://hserv/lr/lr12345678.pdf||||F|P

```

Negative acknowledgement sent by the Order Results Tracker:

1110 The ERR-4 = 'E' indicates that the message could not be integrated. The ERR-3 HL7 error code = 206 informs of the cause: a database locked. The MSA-1 = 'AR' says that the incoming message has been application-rejected. In this particular case, the rejection is not related to a value not acceptable in the MSH segment, therefore the sender should repeat its message later.

```

MSH|^~\&|ORT||OF|Cytology|200310060932||ACK^R01^ACK|401|T|2.5||||USA|EN
MSA|AR|015
1115 ERR||206^Application record locked|E

```

Repetition of the same result message by the Order Filler, one minute later

```

MSH|^~\&|OF|Chemistry|ORT||200310060931||ORU^R01^ORU_R01|015|T|2.5||||USA|EN
PID|1||6543210^^Abbeville Hospital^PI||ILL^JOHN^^^^^L||19810101|M
PVI|1|I|||||9998888
1120 ORC|SC|9876543^Nephro|777^Nephro|CM||||200310060710|^NURSE^JANET|||||
Nephrology^^^^^FI^^NE03
OBR|1|9876543^Nephro|654^chemistry|82575^Creatinine clearance^C4|||||^COLLECT^JOHN
|P||||^NEPHRO^^^DR||||200310060929||F||||&CYTO&JANE^200310060929
TQ1|1|||||R
1125 OBX|1|NM|2164-2^CREATININE CLEARANCE^LN||52.7|ml/min|88-174|L|S|F|||200310060735
SPM|1|654_1^chemistry|SER|||||P|||||200310060735|200310060821||Y|||||1
OBX|1|NM|15045-8^SERUM CREATININE^LN||93|umol/l|50-100|N||F|||200310060735
SPM|2|654_2^chemistry|UR|||||P|||||200310060735|200310060821||Y|||||1
1130 OBX|1|NM|13362-9^URINE COLLECTION DURATION^LN||24|hr||||F|||200309060735
OBX|2|NM|19153-6^URINE SPECIMEN VOLUME^LN||2400|ml||||F|||200309060735
OBX|3|NM|14684-5^24H URINE CREATININE^LN||7.06|mmol|8-16 (/24hr)|L||F||| 200310060830
ORC|SC||777^Nephro||||200805191100
OBR|2|98765432^Nephro|6542^chemistry|11502-2^LABORATORY
REPORT.TOTAL^LN|||||F
1135 OBX|1|RP|11502-2^LABORATORY REPORT.TOTAL^LN||file://hserv/lr/lr12345678.pdf||||F|P

```

Positive acknowledgement sent by the Order Results Tracker:

```

MSH|^~\&|ORT||OF|Cytology|200310060935||ACK^R01^ACK|401|T|2.5||||USA|EN
MSA|AA|015

```

3.5 Microbiology with Two Specimens and Three Germs Identified

1140 3.5.1 Storyboard

This storyboard illustrates the use of transaction LAB-2 to notify generated batteries at the Order Filler level (i.e., antibiotic susceptibilities, within the same placer group number).

Dr. Physician orders Microscopy and Culture for two different specimens collected from the same patient. The first specimen is Mid Stream Urine and the second one is Pus taken from a

1145 wound on patient's left toe. Since several batteries could be performed on each specimen (e.g., Microscopy and Culture, identification of organism, Antibiotic Susceptibility) the Order Placer transmits an OML^O33 message. Since both specimens are part of the same prescription, they are grouped via the Placer Group Number '777'.

The patient is an Outpatient in Emergency ward.

1150 We presume that all tests are performed manually and that results are directly entered by the laboratory technician in the Order Filler system, there is then neither LAB-4, nor LAB-5 transaction in this story board. We also presume that results for observations related to the urine specimen are transferred as soon they are available, whilst the Clinical Expert desires to review results related to other specimen types before they are released.

1155 In this storyboard, a CIS application implements both Actors Order Placer and Order Result Tracker, which suppresses the need for OML messages “Status Change” from OF to OP.

Human actors and organizations participating to the process:

Assigning authority: Memphis Hosp 1

Placer: Emergency Ward

1160 Filler: Microbiology

Ordering facility: Emergency Ward

Patient: Adam Everyman Jr., account number: 12345 (check-digit 5 modulo 10), class = outpatient

Order placed by: Dr. PHYSICIAN, phone number 821, ID number in the hospital 222222.

1165 Placer order enterer: Nancy NURSE, ID number 222221

Specimen collector: Nancy NURSE, ID number 222221

Technician: Terry BACK, ID number 333231

Clinical expert: Mike ROSCOP, ID number 444642

1170 ID numbers used by the workflow:

ID number	Value	Assigned by
Patient ID	12345	Admission office (ADT)
Care unit order for Urine Spec.	12345679	Emergency Ward (OP)
Care unit order for Pus Spec.	12345670	Emergency Ward (OP)
Care unit order group	777	Emergency Ward (OP)
1 st specimen	123456791	Emergency Ward (OP)
2 nd specimen	123456701	Emergency Ward (OP)
Laboratory order for the Urine	MSU0309922	Microbiology laboratory (OF)
Laboratory order for the PUS	PUS0300666	Microbiology laboratory (OF)

Day 1 at 8:10 LAB-1 interaction: The two specimens are collected and transmitted to the Microbiology laboratory in Routine. The Order Placer sends a message “new order” (NW) to the order placer.

1175 **Day 1 at 8:20 LAB-3 interaction:** The laboratory checks the specimens and schedules the work. The Order Filler notifies Order Result Tracker of the scheduled work.

Day 1 at 14:46 LAB-3 interaction: After Microscopy for the Urine Specimen is achieved, the Order Filler notifies these partial results to the Order Result Tracker without waiting for the clinical validation.

1180 **Day 2 at 09:40 LAB-2 and LAB-3 interactions:** The following day, the Urine culture is positive, the laboratory adds Organism identification and Antibiotic Susceptibility test for this specimen. The Order Filler requires a Placer Order Number to the Order Placer for the added tests (Transaction LAB-2) and notifies this action to the Order Result Tracker via transaction LAB-3.

1185 **Day 2 at 09:45 LAB-2 and LAB-3 interactions:** The result of Microscopy and Culture is positive for the Pus specimen, the clinical expert has validated these preliminary results and the laboratory adds Organism identification and Antibiotic Susceptibility test for this specimen. The Order Filler requires a Placer Order Number to the Order Placer for the added tests (Transaction LAB-2) and it notifies this action to the Order Result Tracker via transaction LAB-3.

1190 **Day 3 at 11:32 LAB-3 interaction:** The next day, organism identification and Antibiotic Susceptibility tests are achieved; final results are transmitted to the Order Result Tracker after the clinical validation has been performed.

3.5.2 Interaction Diagram

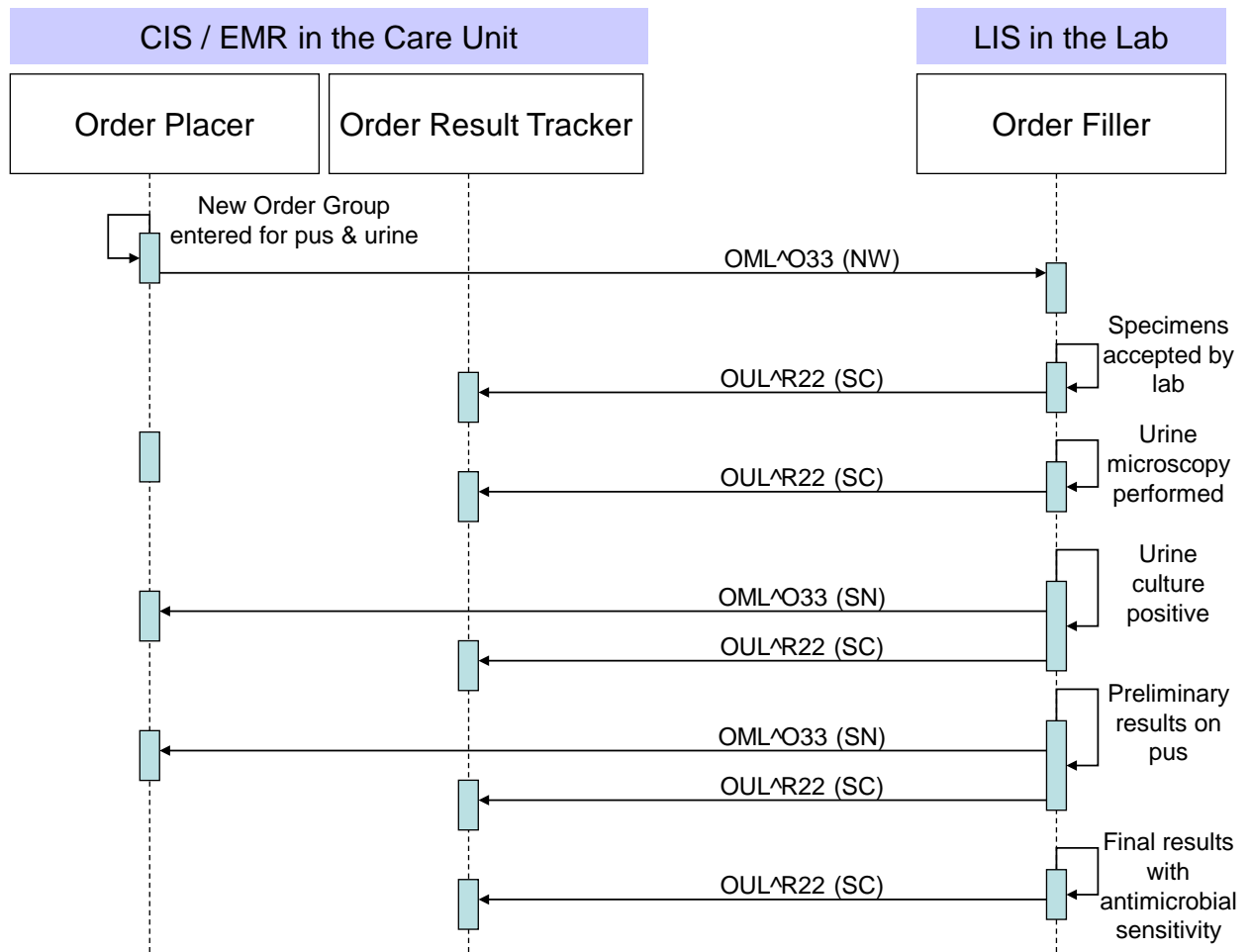

1195

This example of microbiology workflow has selected the OUL^R22 message structure to convey the results back to the EMR system, because this specimen-centric message structure is particularly appropriate for microbiology results, which are usually specimen-centric, and for which the provision of specimen data is of key importance to the receiving system.

1200

Nevertheless, ORU^R01 could also have been used instead, providing the same specimen data in a SPECIMEN segment group at the bottom of each ORDER_OBSERVATION segment group, as stated in Section 3.3.5.2 “ORU^R01 Static Definition”. Alternative messages using ORU^R01 are shown on the first and last LAB-3 interaction of this use case.

1205 **3.5.3 Messages**

3.5.3.1 LAB-1 (OP → OF): Message “New order” with Two Specimens

Day 1 at 8:10 A new placer order sent to the Order Filler.

```
MSH|^~\&|OP|Emergency Ward|OF|Microbiology|200309060810||OML^O33^OML_O33|msgOP123|
T|2.5|123|||USA|EN
1210 PID|1||12345^5^M10^Memphis_Hosp^PI||EVERYMAN^ADAM^^JR^^L|19800101|M
PV1|1|O|Ward|||||||12345
SPM|1|123456791^Emergency|MSU^Mid Stream Urine^L|||||P|||||200309060800|||||1
ORC|NW|12345679^Emergency|777^Emergency|||||200309060800|222221^NURSE^NANCY|||||
|Emergency Ward^^^^^FI^^EW00
1215 TQ1|||||R
OBR|1|12345679^Emergency||87086^Urine Microscopy and Culture^C4|||||S|||||
22222^PHYSICIAN^^^^DR|
SPM|2|123456701^Emergency|PUS||||TOE|LEFT|P|||||200309060805|||||1
ORC|NW|12345670^Emergency|777^Emergency|||||200309060800|222221^NURSE^NANCY|||||
1220 |Emergency Ward^^^^^FI^^EW00
TQ1|||||R
OBR|1|12345670^Emergency||87040^Microscopy and Culture^C4|||||222221^NURSE^NANCY
|S|||||22222^PHYSICIAN^^^^DR|
```

The related acknowledgement message isn't shown.

1225 **3.5.3.2 LAB-3 (OF → ORT): Message “Order Status Change”**

Day 1 at 8:20 The Order Result Tracker is informed that the laboratory has accepted the specimens for a new microbiology order:

```
MSH|^~\&|OF|Microbiology|ORT||200309060820||OUL^R22^OUL_R22|msgOF12|T|2.5|123|||
USA|EN
1230 PID|1||12345^5^M10^Memphis_Hosp^PI||EVERYMAN^ADAM^^JR^^L|19800101|M
PV1|1|O|Ward|||||||12345
SPM|1|123456791^Emergency|MSU^Mid Stream
Urine^L|||||P|||||200309060800|200309060818||Y|...
1235 OBR|1|12345679^Emergency|MSU0309922^Micro|87086^Urine Microscopy and Culture^C4|||||
||||22222^PHYSICIAN^^^^DR|||||I
ORC|SC|12345679^Emergency|777^Emergency|IP|||||200309060818|||||
Emergency Ward^^^^^FI^^EW00
SPM|2|123456701^Emergency|PUS||||TOE|LEFT|P|||||200309060805|200309060818||Y|...
1240 OBR|1|12345670^Emergency|PUS0300666^Micro|87040^Microscopy and
Culture^C4|||||222221^NURSE^NANCY|||||22222^PHYSICIAN^^^^DR|||||I
ORC|SC|12345670^Emergency|777^Emergency|IP|||||200309060818|||||
Emergency Ward^^^^^FI^^EW00
```

The related acknowledgement message isn't shown.

3.5.3.3 LAB-3 (OF → ORT): Message “Status Changed”

1245 Day 1 at 14:46 Urine Microscopy results are sent, not clinically validated (i.e., not verified):

```
MSH|^~\&|OF|Microbiology|ORT||200309061446||OUL^R22^OUL_R22|msgOF14|T|2.5|123|||USA|
EN
PID|1||12345^5^M10^Memphis_Hosp^PI||EVERYMAN^ADAM^^JR^^L|19800101|M
PV1|1|O|Ward|||||||12345
1250 SPM|1|123456791^Emergency|MSU^Mid Stream
Urine^L|||||P|||||200309060800|200309060818||Y|...
```

```

1255 OBR|1|12345679^Emergency|MSU0309922^Micro|87086^Urine Microscopy and Culture^C4|||||
|||222222^PHYSICIAN^^^DR|||||MB|A
ORC|SC|12345679^Emergency||777^Emergency|A|||200309060818|||||
Emergency Ward^^^^^FI^^EW00
TQ1|||||R
OBX|1|CE|20453-7^Epithelial Cells^LN|value||N||R||200309061445|333231^BACK^TERRY
OBX|2|NM|20455-2^Leukocytes^LN|value/ml|N||R||200309061445|333231^BACK^TERRY
1260 OBX|3|NM|32776-7^Erythrocytes^LN|value/ml|N||R||200309061445|333231^BACK^TERRY
OBX|4|CE|24124-0^Casts^LN|value||N||R||200309061445|333231^BACK^TERRY
OBX|5|NM|699-9^Organism Count^LN|value/ml|N||R||200309061445|333231^BACK^TERRY
OBX|6|20430-5^Culture^LN||||N||I||200309070935|333231^BACK^TERRY

```

The related acknowledgement message isn't shown.

The same content could also have been provided using this ORU^R01 message:

```

1265 MSH|^~\&|OF|Microbiology|ORT||200309060820||ORU^R01^ORU_R01|msgOF12|T|2.5|123|||
USA|EN
PID|1||12345^5^M10^Memphis_Hosp^PI|EVERYMAN^ADAM^^JR^^L|19800101|M
1270 PV1|1|O|Ward|||||12345
ORC|SC|12345679^Emergency||777^Emergency|IP|||200309060818|||||
Emergency Ward^^^^^FI^^EW00
OBR|1|12345679^Emergency|MSU0309922^Micro|87086^Urine Microscopy and Culture^C4|||||
|||222222^PHYSICIAN^^^DR|||||I
SPM|1|123456791^Emergency|MSU^Mid Stream
1275 Urine^L|||||P|||||200309060800|200309060818||Y|...
ORC|SC|12345670^Emergency||777^Emergency|IP|||200309060818|||||
Emergency Ward^^^^^FI^^EW00
OBR|1|12345670^Emergency|PUS0300666^Micro|87040^Microscopy and
1280 Culture^C4|||||222221^NURSE^NANCY|||||222222^PHYSICIAN^^^DR|||||I
SPM|1|123456701^Emergency|PUS|||TOE|LEFT|P|||||200309060805|200309060818||Y|...

```

3.5.3.4 LAB-2(OF → OP): Message “Send Order Number”

Day 2 at 9:40 Urine Culture is positive with two microorganisms detected, not identified yet., Reflex tests Organism Identification and two Antimicrobial Susceptibility batteries are added.

1285 For each, a placer order number is requested from the Order Placer, within Placer Group Number 777^Emergency.

```

1290 MSH|^~\&|OF|Microbiology|OP|Emergency Ward|200309070940||OML^O33^OML_O33|msgOF15|
T|2.5|123|||USA|EN
PID|1||12345^5^M10^Memphis_Hosp^PI|EVERYMAN^ADAM^^JR^^L|19800101|M
PV1|1|O|Ward|||||12345
SPM|1|123456791^Emergency|MSU^Mid Stream
Urine^L|||||P|||||200309060800|200309060818||Y|...
1295 ORC|SN||777^Emergency|||200309070938|333231^BACK^TERRY|||||
Emergency Ward^^^^^FI^^EW00
OBR|1||MSU03099221^Micro|87088^Organism Identification^C4|||||
G|||222222^PHYSICIAN^^^DR|||||MB
ORC|SN||777^Emergency|||200309070938|333231^BACK^TERRY|||||Emergency
Ward^^^^^FI^^EW00
1300 OBR|2||MSU03099222^Micro|87186^Antibiotic Susceptibility^C4|||||
G|||222222^PHYSICIAN^^^DR|||||MB

```

ORC | SN | | 777^Emergency | | | | 200309070938 | 333231^BACK^TERRY | | | | | | | | Emergency
Ward^^^^^^FI^^EW00
1305 OBR | 3 | MSU03099223^Micro | 87186^Antibiotic Susceptibility^C4 | | | | | | | |
G | | | | 222222^PHYSICIAN^^^DR | | | | | | | | MB

Acknowledgement sent by the Order Placer:
MSH | ^~\& | OP | Emergency
Ward | OF | Microbiology | 200309070940 | | ORL^O34^ORL_O34 | msgOP123 | T | 2.5 | 123 | | | | USA | | EN
MSA | AA | msgOF15
1310 PID | 1 | | 12345^5^M10^Memphis_Hosp^PI | | EVERYMAN^ADAM^^JR^^L | 19800101 | M
SPM | 1 | 123456791^Emergency | | MSU^Mid Stream
Urine^L | | | | | P | | | | | 200309060800 | 200309060818 | | Y | ...
ORC | NA | 12345681^Emergency | | 777^Emergency | | | | 200309070938 | 333231^BACK^TERRY | | | | | | | |
Emergency Ward^^^^^^FI^^EW00
1315 OBR | 1 | 12345681^Emergency | MSU03099221^Micro | 87088^Organism Identification^C4 | | | | | | | |
G | | | | 222222^PHYSICIAN^^^DR | | | | | | | | MB
ORC | NA | 12345682^Emergency | | 777^Emergency | | | | 200309070938 | 333231^BACK^TERRY | | | | | | | |
Emergency Ward^^^^^^FI^^EW00
1320 OBR | 2 | 12345682^Emergency | MSU03099222^Micro | 87186^Antibiotic Susceptibility^C4 | | | | | | | |
G | | | | 222222^PHYSICIAN^^^DR | | | | | | | | MB
ORC | NA | 12345683^Emergency | | 777^Emergency | | | | 200309070938 | 333231^BACK^TERRY | | | | | | | |
Emergency Ward^^^^^^FI^^EW00
OBR | 3 | 12345683^Emergency | MSU03099223^Micro | 87186^Antibiotic Susceptibility^C4 | | | | | | | |
G | | | | 222222^PHYSICIAN^^^DR | | | | | | | | MB

1325 **3.5.3.5 LAB-3 (OF → ORT): Message “Status Changed”**

Day 2 at 09:42 Results for Urine Microscopy and Culture are released. Organism Identification and Antibiotic Susceptibility tests have been added

Note: The Order Placer has acknowledged transaction LAB-2 and an Order Placer Number has been added to each test added by the laboratory

1330 MSH | ^~\& | OF | Microbiology | ORT | | 200309070942 | | OUL^R22^OUL_R22 | msgOF16 | T | 2.5 | 123 | | | | USA | |
EN
PID | 1 | | 12345^5^M10^Memphis_Hosp^PI | | EVERYMAN^ADAM^^JR^^L | 19800101 | M
PV1 | 1 | O | Ward | | | | | | | | | | 12345
1335 SPM | 1 | 123456791^Emergency | | MSU^Mid Stream Urine^L | | | | | P | | | | | 200309060800 |
200309060818 | | Y | ...
OBR | 1 | 12345679^Emergency | MSU0309922^Micro | 87086^Urine Microscopy and Culture^C4 | | | | | | | |
| | | | 222222^PHYSICIAN^^^DR | | | | | | | | MB | R
ORC | SC | 12345679^Emergency | | 777^Emergency | | A | | | | 200309060818 | | | | | | | |
Emergency Ward^^^^^^FI^^EW00
1340 TQ1 | | | | | | | | R
OBX | 1 | CE | 20453-7^Epithelial Cells^LN | | value | | | N | | | R | | | 200309061445 | | 333231^BACK^TERRY
OBX | 2 | NM | 20455-2^Leukocytes^LN | | value | /ml | | N | | | R | | | 200309061445 | | 333231^BACK^TERRY
OBX | 3 | NM | 32776-7^Erythrocytes^LN | | value | /ml | | N | | | R | | | 200309061445 | | 333231^BACK^TERRY
OBX | 4 | CE | 24124-0^Casts^LN | | value | | | N | | | R | | | 200309061445 | | 333231^BACK^TERRY
1345 OBX | 5 | NM | 699-9^Organism Count^LN | | value | /ml | | N | | | R | | | 200309061445 | | 333231^BACK^TERRY
OBX | 6 | CE | 20430-5^Culture^LN | | 2ORG^Two Organisms^L | | | N | | | R | | | 200309070935 |
| 333231^BACK^TERRY
OBR | 2 | 12345681^Emergency | MSU03099221^Micro | 87088^Organism Identification^C4 | | | | | | | |
G | | | | 222222^PHYSICIAN^^^DR | | | | | | | | MB | S
1350 ORC | SC | 12345681^Emergency | | 777^Emergency | | IP | | | | 200309070938 | 333231^BACK^TERRY | | | | | | | |
| | Emergency Ward^^^^^^FI^^EW00
OBR | 3 | 12345682^Emergency | MSU03099222^Micro | 87186^Antibiotic Susceptibility^C4 | | | | | | | |
G | | | | 222222^PHYSICIAN^^^DR | | | | | | | | MB | S

1355 ORC | SC | 12345682^Emergency | 777^Emergency | IP | | | 200309070938 | 333231^BACK^TERRY | | | | | | | |
| Emergency Ward^^^^^FI^^EW00
OBR | 4 | 12345683^Emergency | MSU03099223^Micro | 87186^Antibiotic Susceptibility^C4 | | | | | | | |
G | | | | 222222^PHYSICIAN^^^^DR | | | | | | | | MB | S
ORC | SC | 12345683^Emergency | 777^Emergency | IP | | | 200309070938 | 333231^BACK^TERRY | | | | | | | |
| Emergency Ward^^^^^FI^^EW00

1360 The related acknowledgement message isn't shown.

3.5.3.6 LAB-2(OF → OP): Message “Send Order Number”

Day 2 at 9:45 Culture for Pus specimen is positive, reflex tests Organism Identification and Antibiotic Susceptibility are added. For each, a placer order number is requested from the Order Placer, within Placer Group Number 777^Emergency.

1365 MSH | ^~\& | OF | Microbiology | OP | Emergency Ward | 200309070945 | | OML^O33 | msgOF18 | T | 2.5 | 123
| | | USA | | EN
PID | 1 | | 12345^5^M10^Memphis_Hosp^PI | | EVERYMAN^ADAM^^JR^^L | 19800101 | M
PV1 | 1 | O | Ward | | | | | | | | | | 12345
SPM | 1 | 123456701^Emergency | | PUS | | | | TOE | LEFT | P | | | | | 200309060805 | 200309060818 | | Y | ...
1370 ORC | SN | | 777^Emergency | | | | 200309070941 | 333231^BACK^TERRY | | | | | | | | | |
Emergency Ward^^^^^FI^^EW00
OBR | 1 | | PUS03006661^Micro | 87088^Organism Identification^C4 | | | | | | | | | |
G | | | | 222222^PHYSICIAN^^^^DR | | | | | | | | MB
ORC | SN | | 777^Emergency | | | | 200309070941 | 333231^BACK^TERRY | | | | | | | | | |
1375 Emergency Ward^^^^^FI^^EW00
OBR | 2 | | PUS03006662^Micro | 87186^Antibiotic Susceptibility^C4 | | | | | | | | | |
G | | | | 222222^PHYSICIAN^^^^DR | | | | | | | | MB

Acknowledgement sent by the Order Placer:

1380 MSH | ^~\& | OP | Emergency
Ward | OF | Microbiology | 200309070945 | | ORL^O34^ORL_O34 | msgOP124 | T | 2.5 | 123 | | | USA | | EN
MSA | AA | msgOF18
PID | 1 | | 12345^5^M10^Memphis_Hosp^PI | | EVERYMAN^ADAM^^JR^^L | 19800101 | M
SPM | 1 | 123456701^Emergency | | PUS | | | | TOE | LEFT | P | | | | | 200309060805 | 200309060818 | | Y | ...
1385 ORC | NA | 12345685^Emergency | 777^Emergency | | | | 200309070941 | 333231^BACK^TERRY | | | | | | | | | |
Emergency Ward^^^^^FI^^EW00
OBR | 1 | | 12345685^Emergency | PUS03006661^Micro | 87088^Organism Identification^C4 | | | | | | | | | |
G | | | | 222222^PHYSICIAN^^^^DR | | | | | | | | MB
ORC | NA | 12345686^Emergency | 777^Emergency | | | | 200309070941 | 333231^BACK^TERRY | | | | | | | | | |
1390 Emergency Ward^^^^^FI^^EW00
OBR | 2 | | 12345686^Emergency | PUS03006662^Micro | 87186^Antibiotic
Susceptibility^C4 | | | | | | | | G | | | | 222222^PHYSICIAN^^^^DR | | | | | | | | MB

3.5.3.7 LAB-3 (OF → ORT): Message “Status Changed”

Day 2 at 09:45 The Clinical Expert has validated the preliminary results of Microscopy and culture for the Pus Specimen.

1395 Note: Although the Culture is positive, the result status is not "Final" other Organisms may grow during the next 24 hours. Results of culture will be considered as final on Day 3 after 48 hours of incubation.

1400 MSH | ^~\& | OF | Microbiology | ORT | 200309070945 | | OUL^R22^OUL_R22 | msgOF19 | T | 2.5 | 123 | | |
USA | | EN
PID | 1 | | 12345^5^M10^Memphis_Hosp^PI | | EVERYMAN^ADAM^^JR^^L | 19800101 | M
PV1 | 1 | O | Ward | | | | | | | | | | 12345
SPM | 1 | 123456701^Emergency | | PUS | | | | TOE | LEFT | P | | | | | 200309060805 | 200309060818 | | Y | ...

1405 OBR|1|12345670^Emergency|PUS0300666^Micro|87040^Microscopy and Culture^C4||||222221^NURSE^NANCY
||||222222^PHYSICIAN^DR|||||MB|P||||444642&ROSCOP&Mike^200309070944
ORC|SC|12345670^Emergency|777^Emergency|A||||200309060818|||||
Emergency Ward^^^^^^FI^^EW00
OBX|1|NM|32761-9^Leukocytes^LN||value||N||F||||200309061125||333231^BACK^TERRY
OBX|2|NM|32762-7^Epithelial Cells^LN||value||N||F||||200309061125||333231^BACK^TERRY
1410 OBX|3|CE|20430-5^Culture^LN||POS^Positive^L||N||P||||200309070935||333231^BACK^TERRY
OBR|2|12345685^Emergency|PUS03006661^Micro|87088^Organism Identification^C4||||G|||||MB|S
ORC|SC|12345685^Emergency|777^Emergency|IP||||200309070941|333231^BACK^TERRY|||||Emergency
Ward^^^^^^FI^^EW00
OBR|3|12345686^Emergency|PUS03006662^Micro|87186^Antibiotic Susceptibility^C4||||G|||||MB|S
1415 ORC|SC|12345686^Emergency|777^Emergency|IP||||200309070941|333231^BACK^TERRY|||||Emergency
Ward^^^^^^FI^^EW00

The related acknowledgement message isn't shown.

3.5.3.8 LAB-3 (OF → ORT): Message “Status Changed”

Day 3 at 11:32 Mike ROSCOP has performed the clinical validation at 11h30. Final results are transmitted.

1420 Note: This message is conforming to the requirements given in Section 3.11 “Microbiology Reporting Rules”. In particular:
Grouping of the results per microorganism using Observation Sub-ID (OBX-4), and association of antimicrobial
sensitivity and microorganism identified, based on the parent/child mechanism: Parent Result (OBR-26) & Parent
(OBR-29). Classification of the results (OBX) below an OBR per microorganism.

1425 MSH|^~\&|OF|Microbiology|ORT||200309081132||OUL^R22^OUL_R22|msgOF21|T|2.5|
123|||USA||EN
PID|1||12345^5^M10^Memphis_Hosp^PI||EVERYMAN^ADAM^JR^^L|19800101|M
PV1|1|O|Ward|||||||12345
1430 SPM|1|123456791^Emergency||MSU^Mid Stream
Urine^L|||||P|||||200309060800|200309060818||Y|...
OBR|1|12345679^Emergency|MSU0309922^Micro|87086^Urine Microscopy and Culture^C4|||||
||||222222^PHYSICIAN^DR|||||MB|F|||||444642&ROSCOP&Mike^200309081130
ORC|SC|12345679^Emergency|777^Emergency|CM|||||200309060818|||||Emergency
Ward^^^^^^FI^^EW00
1435 TQ1|||||R
OBX|1|CE|20453-7^Epithelial Cells^LN||value||N||F||||200309061445||333231^BACK^TERRY
OBX|2|NM|20455-2^Leukocytes^LN||value|/ml|N||F||||200309061445|...
OBX|3|NM|32776-7^Erythrocytes^LN||value|/ml|N||F||||200309061445|...
1440 OBX|4|CE|24124-0^Casts^LN||value||N||F||||200309061445||333231^BACK^TERRY
OBX|5|NM|699-9^Organism Count^LN||value|/ml|N||F||||200309061445|...
OBX|6|CE|20430-5^Culture^LN||2ORG^Two Organisms^L||N||F||||200309070935|...
OBR|2|12345681^Emergency|MSU03099221^Micro|87088^Organism Identification^C4|||||
|||||MB|F|||||444642&ROSCOP&Mike^200309081130
1445 ORC|SC|12345681^Emergency|777^Emergency|CM|||||200309070938|333231^BACK^TERRY|||||
||Emergency Ward^^^^^^FI^^EW00
OBX|1|ST|11475-1^Micro organism identified^LN|1|E. Coli||N||F|||...
OBX|2|ST|11475-1^Micro organism identified^LN|2|Strepto D||N||F|||...
OBR|3|12345682^Emergency|MSU03099222^Micro|87186^Antibiotic Susceptibility^C4
|||||MB|F|||||11475-1&Micro organism identified^LN^1^E. Coli|||
1450 12345681&Emergency^MSU03099221&Micro||444642&ROSCOP&Mike^200309081130
ORC|SC|12345682^Emergency|777^Emergency|CM|||||200309070938|333231^BACK^TERRY|||||
||Emergency Ward^^^^^^FI^^EW00
OBX|1|SN|18861-5^Amoxicillin^LN|1|>=^0.512|µg/ml||R||F|||200309081107|...
1455 OBX|2|SN|18864-9^Ampicillin^LN|1|<^0.128|µg/ml||I||F|||200309081107|...
OBX|3|SN|18952-2^Nalidixate^LN|1|>=^2.0|µg/ml||R||F|||200309081107|...

IHE Pathology & Laboratory Medicine Technical Framework, Vol. 2x (PaLM TF-2x):
Transactions

ORC|SC|12345679^Emergency||777^Emergency|CM|||200309060818|||Emergency
Ward^^^^^FI^^EW00

1515 OBR|1|12345679^Emergency|MSU0309922^Micro|87086^Urine Microscopy and Culture^C4|||
|||222222^PHYSICIAN^^^DR|||MB|F|||444642&ROSCOP&Mike^200309081130
TQ1|||R

OBX|1|CE|20453-7^Epithelial Cells^LN|value||N||F||200309061445|333231^BACK^TERRY

OBX|2|NM|20455-2^Leukocytes^LN|value/ml|N||F||200309061445|...

OBX|3|NM|32776-7^Erythrocytes^LN|value/ml|N||F||200309061445|...

1520 OBX|4|CE|24124-0^Casts^LN|value||N||F||200309061445|333231^BACK^TERRY

OBX|5|NM|699-9^Organism Count^LN|value/ml|N||F||200309061445|...

OBX|6|CE|20430-5^Culture^LN|2ORG^Two Organisms^L||N||F||200309070935|...

SPM|1|123456791^Emergency|MSU^Mid Stream
Urine^L|||P|||200309060800|200309060818|Y|...

1525 ORC|SC|12345681^Emergency||777^Emergency|CM|||200309070938|333231^BACK^TERRY|||
||Emergency Ward^^^^^FI^^EW00

OBR|2|12345681^Emergency|MSU03099221^Micro|87088^Organism Identification^C4|||
|||MB|F|||444642&ROSCOP&Mike^200309081130

OBX|1|ST|11475-1^Micro organism identified^LN|1|E. Coli||N||F||...

OBX|2|ST|11475-1^Micro organism identified^LN|2|Strepto D||N||F||...

1530 SPM|1|123456791^Emergency|MSU^Mid Stream
Urine^L|||P|||200309060800|200309060818|Y|...

ORC|SC|12345682^Emergency||777^Emergency|CM|||200309070938|333231^BACK^TERRY|||
||Emergency Ward^^^^^FI^^EW00

1535 OBR|3|12345682^Emergency|MSU03099222^Micro|87186^Antibiotic Susceptibility^C4
|||MB|F||11475-1&Micro organism identified&LN^1|E. Coli||
12345681&Emergency^MSU03099221&Micro||444642&ROSCOP&Mike^200309081130

OBX|1|SN|18861-5^Amoxicillin^LN|1|>=^0.512|ug/ml|R||F||200309081107|...

OBX|2|SN|18864-9^Ampicillin^LN|1|<^0.128|ug/ml|I||F||200309081107|...

1540 OBX|3|SN|18952-2^Nalidixate^LN|1|>=^2.0|ug/ml|R||F||200309081107|...

OBX|4|SN|18956-3^Norfloxacin^LN|1|value|ug/ml|I||F||200309081107|...

OBX|5|SN|18928-2^Gentamicin^LN|1|<^0.032|ug/ml|S||F||200309081107|...

OBX|6|SN|25596-8^Fosfomycine^LN|1|<^0.1|ug/ml|S||F||200309081107|...

OBX|7|SN|18955-5^Nitrofuranton^LN|1|<^0.25|ug/ml|S||F||200309081107|...

SPM|1|123456791^Emergency|MSU^Mid Stream
Urine^L|||P|||200309060800|200309060818|Y|...

1545 ORC|SC|12345683^Emergency||777^Emergency|CM|||200309070938|333231^BACK^TERRY|||
||Emergency Ward^^^^^FI^^EW00

OBR|4|12345683^Emergency|MSU03099223^Micro|87186^Antibiotic Susceptibility^C4
|||MB|F||11475-1&Micro organism identified&LN^2^Strepto D||
12345681&Emergency^MSU03099221&Micro||444642&ROSCOP&Mike^200309081130

1550 OBX|8|SN|18965-4^Penicillin G^LN|2|<^0.5|ug/ml|S||F||200309081107|...

OBX|9|SN|18861-5^Amoxicillin^LN|2|value|ug/ml|S||F||200309081107|...

OBX|10|SN|18864-9^Ampicillin^LN|2|value|ug/ml|S||F||200309081107|...

OBX|11|SN|18928-2^Gentamicin^LN|2|value|ug/ml|R||F||200309081107|...

1555 OBX|12|SN|18917-5^Doxycycline^LN|2|value|ug/ml|R||F||200309081107|...

OBX|13|SN|18919-1^Erythromycin^LN|2|value|ug/ml|R||F||200309081107|...

OBX|14|SN|18974-6^Rifampicin^LN|2|value|ug/ml|S||F||200309081107|...

OBX|15|SN|18938-1^Lincomycin^LN|2|value|ug/ml|R||F||200309081107|...

SPM|1|123456791^Emergency|MSU^Mid Stream
Urine^L|||P|||200309060800|200309060818|Y|...

1560 ORC|SC|12345670^Emergency||777^Emergency|CM|||200309060818|||Emergency
Ward^^^^^FI^^EW00

OBR|1|12345670^Emergency|PUS0300666^Micro|87040^Microscopy and
Culture^C4|||222221^NURSE^NANCY

1565 |||222222^PHYSICIAN^^^DR|||MB|F|||444642&ROSCOP&Mike^200309081130

OBX|1|CE|32761-9^Leukocytes^LN|value||N||F||200309060830

OBX|2|CE|32762-7^Epithelial Cells^LN|value||N||F||200309060830|333231^BACK^TERRY

```

OBX|3|CE|20430-5^Culture^LN||POS^Positive^L||N||F||200309070935|...
|333231^BACK^TERRY
1570 SPM|2|123456701^Emergency|PUS||TOE|LEFT|P||200309060805|200309060818|Y|...
ORC|SC|12345685^Emergency|777^Emergency|CM||200309070941|333231^BACK^TERRY|||
|Emergency Ward^^^^^FI^^EW00
OBR|2|12345685^Emergency|PUS03006661^Micro|87072^Organism
Identification^C4|||MB|F||444642&ROSCOP&Mike^200309081130
1575 OBX|1|ST|21020-3^Micro organism identified^LN|I|Staph Aureus||N||F||200309080830|...
SPM|2|123456701^Emergency|PUS||TOE|LEFT|P||200309060805|200309060818|Y|...
ORC|SC|12345686^Emergency|777^Emergency|CM||200309070938|333231^BACK^TERRY|||
|Emergency Ward^^^^^FI^^EW00
OBR|3|12345686^Emergency|PUS03006662^Micro|87186^Antibiotic
1580 Susceptibility^C4|||MB|F|21020-3&Micro organism
identified&LN^I^Staph Aureus||
12345685&Emergency^PUS03006661&Micro||444642&ROSCOP&Mike^200309081130
OBX|1|SN|18928-2^Gentamicin^LN|1|value|ug/ml|S||F||200309080830|...
1585 OBX|2|SN|18996-9^Tobramycin^LN|1|value|ug/ml|R||F||200309080830|...
OBX|3|SN|18954-8^Netilmicin^LN|1|value|ug/ml|S||F||200309080830|...
OBX|4|SN|18959-7^Ofloxacin^LN|1|value|ug/ml|S||F||200309080830|...
OBX|5|SN|18917-5^Doxycycline^LN|1|value|ug/ml|S||F||200309080830|...
OBX|6|SN|19000-9^Vancomycin^LN|1|value|ug/ml|S||F||200309080830|...
OBX|7|SN|18974-6^Rifampicin^LN|1|value|ug/ml|S||F||200309080830|...
1590 OBX|8|SN|25596-8^Fosfomycine^LN|1|value|ug/ml|S||F||200309080830|...
SPM|2|123456701^Emergency|PUS||TOE|LEFT|P||200309060805|200309060818|Y|...

```

3.6 Rejection of a Specimen

3.6.1 Storyboard

1595 This example corresponds to the use case described in Volume 1 as “4.2.4 Order Filler rejects a specimen prior to result testing”. The context for this use-case will be based on the simplification of having the actors OP and ORT grouped.

A physician in a ward requests a laboratory test “BG_CLAIR_CREAT_COCKROFT” for a patient “Marge Smith”.

1600 The Order Placer sends a LAB-1 “order create” message to the Order Filler, delivering the Order Group “2011122446_OPGN” with associated relevant information including a Specimen with bar coded id = “1200000808”

Upon reception, the Order Filler application accepts the content of the Order, and notifies a Filler Order Number in the acknowledgement message sent back to the Order Placer application.

1605 Using the Order Filler application, the laboratory staff checks each Order with the corresponding specimens and detects a non-conformity for a particular specimen: “1200000808”. The specimen will be cancelled in the Order Filler application. During the cancelation of the specimen, a reason will be asked to allow feedback towards a Nurse or the Physician.

This action will also lead to the cancelation of the related laboratory test.

1610 The Order Filler informs the Order Placer / Order Result Tracker about the rejection executing the laboratory test

A nurse or the Physician detects this non-conformity and decides to take a new specimen sample from the patient to enable the laboratory fulfilling the laboratory test.

The Order Placer will inform the Order Filler about this new Specimen with new barcode id = “1200000809” and re-order the laboratory test within the already existing Order Group.

1615 The Order Filler will update the Order Group and provide a status feedback to the Order Result Tracker informing about the new work for this new specimen.

3.6.2 Interaction Diagram

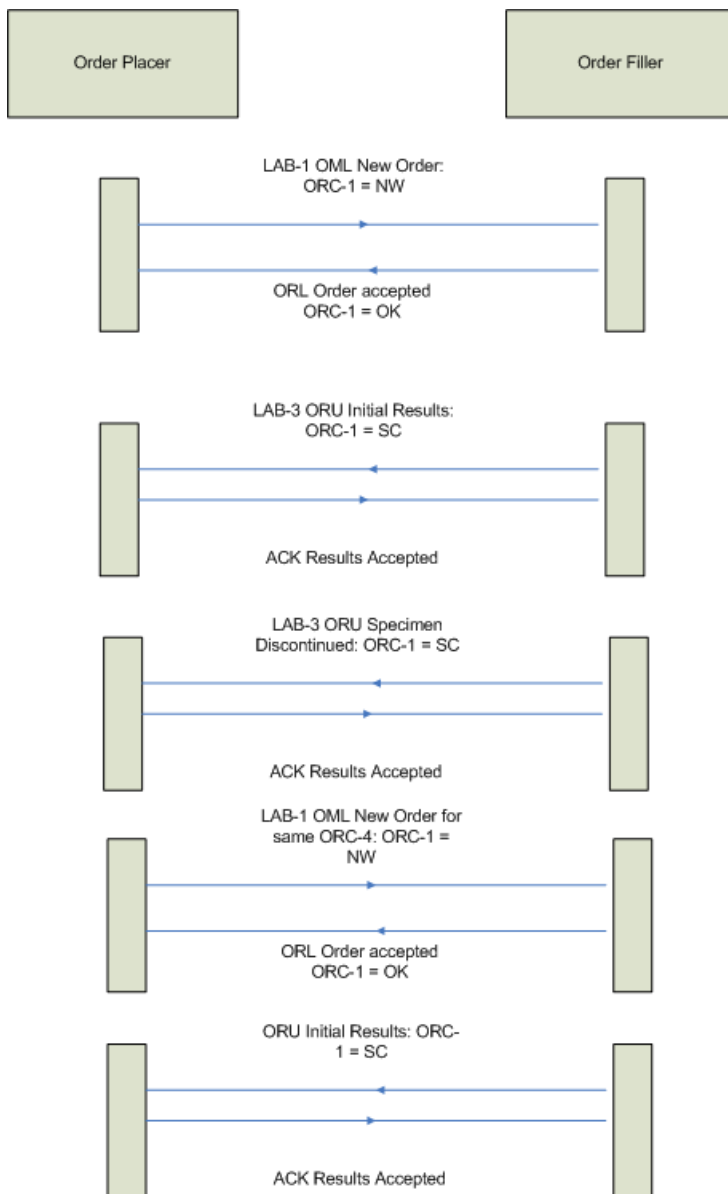

1620 **3.6.3 Messages**

3.6.3.1 LAB-1 (OP -> OF):Message "Create new order"

MSH|^~\&||APHP_CORDIER|20111213174100||OML^O21^OML_O21|391815247250212427|P|2.5|||
PID|1||7501052489^^^PSL||Smith^Marge^^^Mrs||19641120|F||^AMAREINS FRANCHELEINS
1625 CESSEINS^^01090^100
PV1|I|||||JC0000407|||||20120203101100|||||V
ORC|NW|2011122446_OP1^APHP|2011122446_OPGN^APHP|SC|||20111213173234||0607^Hart^Andr
e^^^Dr^hcpr|0607_N^^^^^^^^^MIPSN|||S_CORDIER^BIOCH_HEMATO^L
1630 TQ1|||||R
OBR|1|2011122446_OP1^APHP|APHP_CREA_COCKROFT^^APHP|||||0607^Hart^Andre^^^Dr^h
cpr|||||S_CORDIER|S
SPM|1|1200000808&PSL|MAT_HEPLIG_PLA^Plasma sur tube héparine lithium avec
gel^L^APHP_HEPLIG_PLA^^APHP|||||0.0^ml&&L|||||20120210101100|||

1635 With:
Order Group number (ORC) = 2011122446_OPGN
Order Placer number (ORC) = 2011122446_OP1
Order Placer assigned specimen number (SPM) = 1200000808

1640 The related acknowledgement message isn't shown.

3.6.3.2 LAB-3 (OF -> ORT/OP) : Acceptance of the order

MSH|^~\&|PSL|E_BG_CORDIER|ORBIS|ResultImport|20120209112212||ORU^R01^ORU_R01|303900235
622598969|P|2.5|||BEL|8859/1|EN
1645 PID|1||7501052489^^^PSL||Smith^Marge||19641120|F
PV1|I|||||JC0000407|||||20120203101100|||||V
ORC|SC|2011122446_OP1^ORBIS|41498^PSL|2011122446_OPGN^ORBIS|SC|||20120209111827||060
7_N^BIOCHIMIE^^^^^dept^MIPSN|0607|||S_CORDIER^BIOCH_HEMATO^L
1650 OBR|1|2011122446_OP1^ORBIS|41498^PSL|BG_CLAIR_CREAT_COCKROFT^Clairance créat
Cockroft^L^APHP_CREA_COCKROFT^^APHP|||20120210101100|||||0607_N^BIOCHIMIE^^^^^dep
t^MIPSN|||||S_CORDIER|S
TQ1|||||R
SPM|1|1200000808&ORBIS^1200000808&PSL|MAT_HEPLIG_PLA^Plasma sur tube héparine lithium
avec gel^L^APHP_HEPLIG_PLA^^APHP|||||0.0^ml&&L||"|||20120210101100|||N

1655 With:
Order Group number = 2011122446_OPGN
Order Placer number = 2011122446_OP1
Order Filler number = 41498
Order Placer assigned specimen number = 1200000808
1660 Order Filler assigned specimen number = 1200000808

The related acknowledgement message isn't shown.

3.6.3.3 LAB-3 (OF -> ORT/OP) : Rejection of a specimen

MSH|^~\&|PSL|E_BG_CORDIER|ORBIS|ResultImport|20120209122308||ORU^R01^ORU_R01|469731566
7455003249|P|2.5|||BEL|8859/1|EN
1665 PID|1||7501052489^^^PSL||Smith^Marge||19641120|F
PV1|I|||||JC0000407|||||20120203101100|||||V
ORC|SC|2011122446_OP1^ORBIS|41498^PSL|2011122446_OPGN^ORBIS|CA|||20120209111827||060
7_N^BIOCHIMIE^^^^^dept^MIPSN|0607|||S_CORDIER^BIOCH_HEMATO^L

1670 OBR|1|2011122446_OP1^ORBIS|41498^PSL|BG_CLAIR_CREAT_COCKROFT^Clairance créat
Cockroft^L^APHP_CREA_COCKROFT^APHP||20120210101100|||0607_N^BIOCHIMIE^^^^^dep
t^MIPSN|||S_CORDIER|X
TQ1|||R
SPM|1|1200000808&ORBIS^1200000808&PSL||MAT_HEPLIG_PLA^Plasma sur tube héparine lithium
avec
1675 gel^L^APHP_HEPLIG_PLA^APHP|||0.0^ml&&L|""||20120210101100|20120209113217|N^N
on Conformite
OBX|1|ST|POIDS^Poids du patient^L^A1652^APHP|Non
Conformite|kg^L|N~N||X||20120210101100|E_BG_CORDIER^BIOCH_URG_CORDIER^L|^L|INTEG
RA_01^L|20120209121943
1680 OBX|2|ST|CREAT^Créatinine^L^A0094^APHP|Non Conformite|umol/l^L|44-
80|N~N||X||20120210101100|E_BG_CORDIER^BIOCH_URG_CORDIER^L|^L|INTEGRA_01^L|2012020
9121943
OBX|3|ST|CLCOCK^Clairance Créatinine Cockroft^L^A2154^APHP|Non
1685 Conformite|ml/min^L|N~N||X||20120210101100|E_BG_CORDIER^BIOCH_URG_CORDIER^L|^L|C
ALCUL_BG^L|20120209121942

With:

Placer Group number = 2011122446_OPGN
Order Placer number = 2011122446_OP1
1690 Order Placer assigned specimen number = 1200000808
Specimen Availability (SPM-20) = N
Specimen Reject Reason (SPM-21) = Non Conformite

The related acknowledgement message isn't shown.

3.6.3.4 LAB-1 (OP->OF): 'New Order' with new specimen for same order group

1695 MSH|^~\&|PSL|E_BG_CORDIER|ORBIS|ResultImport|20120209140214||ORU^R01^ORU_R01|537296337
8993344693|P|2.5|||BEL|8859/1|EN
PID|1||7501052489^PSL|Smith^Marge||19641120|F
PV1||I|||JCO000407|||20120203101100|||V
1700 ORC|SC|2011122447_OP1^ORBIS|41499^PSL|2011122446_OPGN^ORBIS|SC||20120209123701||060
7_N^BIOCHIMIE^^^^^dept^MIPSN|0607||S_CORDIER^BIOCH_HEMATO^L
OBR|1|2011122447_OP1^ORBIS|41499^PSL|BG_CLAIR_CREAT_COCKROFT^Clairance créat
Cockroft^L^APHP_CREA_COCKROFT^APHP||20120210101100|||0607_N^BIOCHIMIE^^^^^dep
t^MIPSN|||S_CORDIER|S
TQ1|||R
1705 SPM|1|1200000809&ORBIS^1200000809&PSL||MAT_HEPLIG_PLA^Plasma sur tube héparine lithium
avec gel^L^APHP_HEPLIG_PLA^APHP|||0.0^ml&&L|""||20120210101100|N

With:
Order group number = 2011122446_OPGN
Order Placer number = 2011122447_OP1
Order Placer assigned specimen number = 1200000809
1710

The related acknowledgement message isn't shown.

Appendices

1715

Appendix A – HL7 v2.x Common Data Types

A.1 CX – Extended Composite ID with Check Digit

Except otherwise specified this data type is constrained in transactions of the PaLM Technical Framework, as shown below:

SEQ	LEN	DT	Usage	CARD	TBL#	COMPONENT NAME
1	15	ST	R	[1..1]		ID Number
2	1	ST	O	[0..1]		Check Digit
3	3	ID	O	[0..1]	0061	Check Digit Scheme
4	227	HD	R	[1..1]	0363	Assigning Authority
5	5	ID	RE	[0..1]	0203	Identifier Type Code
6	227	HD	O	[0..1]		Assigning Facility
7	8	DT	O	[0..1]		Effective Date
8	8	DT	O	[0..1]		Expiration Date
9	705	CWE	O	[0..1]		Assigning Jurisdiction
10	705	CWE	O	[0..1]		Assigning Agency or Department

1720 A.2 EI – Entity Identifier

Except otherwise specified this data type is constrained in transactions of the PaLM Technical Framework, as shown below:

SEQ	LEN	DT	Usage	CARD	TBL#	COMPONENT NAME
1	16	ST	R	[1..1]		Entity Identifier
2	20	IS	C	[0..1]	0363	Namespace ID
3	199	ST	C	[0..1]		Universal ID
4	6	ID	C	[0..1]	0301	Universal ID Type

1725 Condition predicate: Either component 2 or both components 3 and 4 are required. Components 2, 3 and 4 may be all present.

The EI is appropriate for machine or software generated identifiers. The generated identifier goes in the first component. The remaining components, 2 through 4, are known as the assigning authority; they can also identify the machine/system responsible for generating the identifier in component 1.

1730 Example 1: AB12345^RiversideHospital

Example 2: AB12345^^1.2.840.45.67^ISO

Example 3: AB12345^RiversideHospital^1.2.840.45.67^ISO

A.3 EIP – Entity Identifier Pair

1735 The usage of this data type in the context of transactions LAB-27, LAB-28 and LAB-29 is specified in Volume 2b.

For other transactions, this data type is constrained in transactions of the PaLM Technical Framework, as shown below:

SEQ	LEN	DT	Usage	CARD	TBL #	COMPONENT NAME
1	427	EI	C	[0..1]		Placer Assigned Identifier
2	427	EI	C	[0..1]		Filler Assigned Identifier

1740 This data type is used for identifying specimens (SPM-2, SPM-3), order groups (ORC-4) and parent orders (OBR-29).

The usage depends upon the kind of object identified, and upon the transaction carrying this object:

For specimens:

- In the context of transactions LAB-1, LAB-2, LAB-3:
 - 1745 • EIP-1 is populated with the specimen ID assigned by the Order Placer actor, if available.
 - EIP-2 is populated with the specimen ID assigned by the Order Filler actor, if available.
- In the context of transactions LAB-4 and LAB-5:
 - EIP-1 is populated with the specimen ID assigned by an actor preceding the Automation Manager in the workflow, if available.
 - 1750 • EIP-2 is populated with the specimen ID assigned by the Automation Manager or by a Laboratory Device, if available.
- In the context of transactions LAB-21, LAB-22, LAB-26:
 - EIP-1 is populated with the specimen ID assigned by an actor preceding the Laboratory Device, if available.
 - 1755 • EIP-2 is populated with the specimen ID assigned by a Laboratory Device, if available.
- In the context of transactions LAB-61 and LAB-62:
 - EIP-1 is populated with the specimen ID assigned by the Label Information Provider actor.
 - EIP-2 is never populated.

- 1760 For order groups (ORC-4) and parent orders (OBR-29), EIP-1 is populated with the identifier assigned by the Order Placer application, if known, and EIP-2 is populated with the identifier accessioned by the Order Filler application, if known.

A.4 HD – Hierarchic Designator

- 1765 Except otherwise specified this data type is constrained in transactions of the PaLM Technical Framework, as shown below:

SEQ	LEN	DT	Usage	CARD	TBL #	COMPONENT NAME
1	20	IS	R	[1..1]	0300	Namespace ID
2	199	ST	C			Universal ID
3	6	ID	C		0301	Universal ID Type

Condition predicate: Data Type HD is populated with:

- Either the first component “Namespace ID” alone, which in this case contains a local identifier of the object.
 - Or with all three components, “Namespace ID” containing the name of the object, “Universal ID” containing its universal OID, and “Universal ID Type” containing the value **ISO**.
- 1770

Appendix B – <Place Holder>

Left blank intentionally.

1775 **Appendix C – Common HL7 Message Segments**

This section describes the common HL7 v2.x message segments used by transaction of the PaLM Technical Framework.

Each table represents a segment. Below the table are commented only the fields for which the technical framework brings some precision on usage. The optional fields are not shown in the table, unless they require a particular comment within the context of the technical framework.

1780

C.1 MSH – Message Header Segment

HL7 v2.5: chapter 2 (2.15 Message control)

This segment defines the intent, source, destination, and some specifics of the syntax of a message.

1785

Table C.1-1: MSH - Message Header

SEQ	LEN	DT	Usage	Card.	TBL#	ITEM #	Element name
1	1	SI	R	[1..1]		00001	Field Separator
2	4	ST	R	[1..1]		00002	Encoding Characters
3	227	HD	R	[1..1]		00003	Sending Application
4	227	HD	R	[1..1]		00004	Sending Facility
5	227	HD	R	[1..1]		00005	Receiving Application
6	227	HD	R	[1..1]		00006	Receiving Facility
7	26	TS	R	[1..1]		00007	Date/Time of Message
8	40	ST	X	[0..0]		00008	Security
9	15	MSG	R	[1..1]		00009	Message Type
10	20	ST	R	[1..1]		00010	Message Control Id
11	3	PT	R	[1..1]		00011	Processing Id
12	60	VID	R	[1..1]		00012	Version ID
14	180	ST	X	[0..0]		00014	Continuation Pointer
15	2	ID	X	[0..0]	0155	00015	Accept Acknowledgement Type
16	2	ID	X	[0..0]	0155	00016	Application Acknowledgement Type
17	3	ID	RE	[0..1]	0399	00017	Country Code
18	16	ID	C	[0..1]	0211	00692	Character Set
19	250	CE	RE	[0..1]		00693	Principal Language of Message
20	20	ID	C	[0..1]	0356	01317	Alternate Character Set Handling Scheme
21	427	EI	RE	[0..*]		01598	Message Profile Identifier

MSH-1 Field Separator (SI), required.

The Pathology and Laboratory Medicine Technical Framework requires that applications support HL7-recommended value that is | (ASCII 124).

1790 **MSH-2 Encoding Characters (ST)**, required.

This field contains the four characters in the following order: the component separator, repetition separator, escape character, and subcomponent separator. The IHE Laboratory Technical Framework requires that applications support HL7-recommended values ^~\& (ASCII 94, 126, 92, and 38, respectively).

1795 **MSH-4 Sending Facility (HD)**, required.

Components: <Namespace ID (IS)> ^ <Universal ID (ST)> ^ <Universal ID Type (ID)>

The Pathology and Laboratory Medicine Technical Framework requires that this field be populated with:

1800 First component (required): Namespace ID. The name of the organizational entity responsible for the sending application.

Second component (optional): The URI (OID) of the organizational entity responsible for the sending application.

1805 Third component (optional): The type of identification URI provided in the second component of this field. The codification of these three components is entirely site-defined. It may be detailed in the national extensions of this framework.

MSH-6 Receiving Facility (HD), required.

Components: <Namespace ID (IS)> ^ <Universal ID (ST)> ^ <Universal ID Type (ID)>

The Pathology and Laboratory Medicine Technical Framework requires that this field be populated with:

1810 First component (required): Namespace ID. The name of the organizational entity responsible for the receiving application.

Second component (optional): The URI (e.g., OID) of the organizational entity responsible for the receiving application.

1815 Third component (optional): The type of identification URI provided in the second component of this field. The codification of these three components is entirely site-defined. It may be detailed in the national extensions of this framework.

MSH-9 Message Type (MSG), required.

Components: <Message Code (ID)> ^ <Trigger Event (ID)> ^ <Message Structure (ID)>

1820 Definition: This field contains the message type, trigger event, and the message structure ID for the message. All three components are required.

Its content is defined within each transaction-specific section of this document.

MSH-10 Message Control Id (ST), required.

1825 Definition: This field contains a number or other identifier that uniquely identifies the message. Each message should be given a unique identifier by the sending system. The receiving system will echo this ID back to the sending system in the Message Acknowledgment segment (MSA). The combination of this identifier and the name of the sending application (MSH-3) should be unique across the Healthcare Enterprise.

MSH-11 Processing ID (PT), required.

Components: <Processing ID (ID)> ^ <Processing Mode (ID)>

1830 HL7 definition: This field indicates whether to process a message as defined in HL7 Application (level 7) Processing rules.

This Pathology and Laboratory Medicine Technical Framework mandates only the first component, with permitted values listed in HL7 table 0103 – Processing ID:

HL7 Table 0103 - Processing ID

Value	Meaning	Comment
D	Debugging	
P	Production	
T	Training	

1835 **MSH-12 Version ID (VID), required.**

Components: <Version ID (ID)> ^ <Internationalisation Code (CE)> ^ <International Version ID (CE)>

Definition: This field is matched by the receiving system to its own version to be sure the message will be interpreted correctly.

1840 The Pathology and Laboratory Medicine Technical framework requires the first component to be populated with a value starting with the character string "2.5" representing HL7 major release 2.5. Later minor releases of this 2.5, like the current release 2.5.1, are also supported by the Technical Framework.

Valid examples: |2.5| |2.5.1|

1845 **MSH-15 Accept Acknowledgment Type (ID), not supported.**

IHE uses only the HL7 original acknowledgement mode.

MSH-16 Application Acknowledgment Type (ID), not supported for the same reason.

MSH-17 Country Code (ID), required if available.

1850 Definition: This field contains the country of origin for the message. The values to be used are those of ISO 3166, with the 3-character (alphabetic form). Refer to HL7 Table 0399 - Country code

Examples of valid values:

JPN = Japan, USA = United States, GBR = United Kingdom, ITA = Italy, FRA = France, NLD = Netherlands.

1855 **MSH-18 Character Set (ID)**, conditional.

Definition: This field contains the character set for the entire message. Refer to HL7 table 0211 - Alternate character sets for valid values.

Examples of valid values:

ASCII: The printable 7-bit ASCII character set.

1860 8859/1: The printable characters from the ISO 8859/1 Character set used by Western Europe. This character set can still be used, but 8859/15 should be used by preference. This character set is the forward-compatible version of 8859/1 and includes new characters such as the Euro currency symbol.

1865 ISO IR87: Code for the Japanese Graphic Character set for information interchange (JIS X 0208-1990).

UNICODE UTF-8: UCS Transformation Format, 8-bit form.

1870 Condition predicate: This field shall only be valued if the message uses a character set other than the 7-bit ASCII character set. Though the field is repeatable in HL7, IHE authorizes only one occurrence (i.e., one character set). The character set specified in this field is used for the encoding of all of the characters within the message.

MSH-19 Principal Language of Message (CE), required if available.

Coded from ISO 639.

Examples: DE = German, EN = English, ES=Spanish, JA = Japanese, FR = French, NL = Dutch, IT = Italian

1875 **MSH-20 Alternate Character Set Handling Scheme (ID)**, conditional.

HL7 definition: When any alternative character sets are used (as specified in the second or later iterations of MSH-18 character sets), and if any special handling scheme is needed, this component is to specify the scheme used, according to HL7 Table 0356- Alternate character set handling scheme as defined below:

1880

HL7 Table 0356 - Alternate Character Set Handling Scheme

Value	Description	Comment
-------	-------------	---------

Value	Description	Comment
ISO 2022-1994	This standard is titled "Information Technology - Character Code Structure and Extension Technique". .	This standard specifies an escape sequence from basic one byte character set to specified other character set, and vice versa. The escape sequence explicitly specifies what alternate character set to be evoked. Note that in this mode, the actual ASCII escape character is used as defined in the referenced ISO document. As noted in 1.7.1, escape sequences to/from alternate character set should occur within HL7 delimiters. In other words, HL7 delimiters are basic one byte characters only, and just before and just after delimiters, character encoding status should be the basic one byte set.
2.3	The character set switching mode specified in HL7 2.5, section 2.7.2, "Escape sequences supporting multiple character sets" and section 2.A.46, "XPN – extended person name".	Note that the escape sequences used in this mode do not use the ASCII "esc" character, as defined in ISO 2022-1994. They are "HL7 escape sequences" as first defined in HL7 2.3, sec. 2.9.2. (Also, note that sections 2.8.28.6.1 and 2.9.2 in HL7 2.3 correspond to sections 2.16.93 and 2.7.2 in HL7 2.5.)
<null>	This is the default, indicating that there is no character set switching occurring in this message.	This is the default.

1885 Condition predicate: This field shall be valued for messages using more than one character set.

Example of HL7 messages in Japan:

MSH-21 Message Profile Identifier (EI), required if available.

1890 For the Pathology and Laboratory Medicine Technical Framework, this field shall only be valued in the messages for which a Message Profile has been officially defined and identified. When multiple message profiles are listed in this field they should be (vendor specific, country specific) constraints of the IHE Laboratory Profile. Note that the overriding of Profile constraints is only allowed in national extensions to this framework.

C.2 NTE – Notes and Comment Segment

HL7 v2.5 : chapter 2 (2.15 Message control)

1895 This segment is used for sending notes and comments.

Information that can be coded in OBX segments or OBR segments shall not be sent in a NTE segment.

Table C.2-1: NTE - Notes and Comment Segment

SEQ	LEN	DT	Usage	Card.	TBL#	ITEM#	Element name
1	4	SI	R	[1..1]		00096	Set ID – NTE
2	8	ID	RE	[0..1]		00097	Source of Comment
3	65536	FT	RE	[0..1]		00098	Comment
4	250	CE	RE	[0..1]		01318	Comment Type

NTE-1 Set ID - NTE (SI), required.

1900 **NTE-2 Source of Comment (ID)**, required but may be empty.

The Technical Framework populates this field with one of these values:

Table C.2-2: Source of Comment

Value	Meaning	Comment
L	Order Filler is the source of the comment	
P	Order Placer is the source of the comment	
A	Automation Manager or Analyzer Manager is the source of the comment	
Z	Analyzer is the source of the comment	
O	Other system is the source of the comment	

NTE-3 Comment (FT), required but may be empty:

1905 This field contains the text of the comment. This text may be formatted. In order to delete an existing comment, the field shall contain a NULL value.

Comment text of identical type and source SHALL be included in the same occurrence of an NTE segment, and not be split over multiple segments.

NTE segments SHALL be used exclusively for comments and notes intended for humans. Contents of NTE 3 SHALL be considered as not interpretable by a machine.

1910 **NTE-4 Comment Type (CE)**, required if known.

The Technical Framework populates this field with one of these values:

Table C.2-3: Comment Type

Value	Meaning	Comment
I	Internal remark, that shall not be sent outside of the laboratory	Used between Automation Manager and Order Filler. Shall not be sent to the Order Result Tracker
C	Comment addressed to medical staff and physician,	Should be sent to the Order Result Tracker or the Order Placer, but should not be showed to the patient
P	Comment addressed to medical staff and physician, may be showed to the patient	Should be sent to the Order Result Tracker or the Order Placer, and may appear on the result report addressed to the patient.

C.3 PID – Patient Identification Segment

HL7 v2.5: chapter 3 (3.4.2)

1915 The PID segment is used by all applications as the primary means of communicating patient identification information. This segment contains permanent patient identifying and demographic information that, for the most part, is not likely to change frequently.

Table C.3-1: PID - Patient Identification Segment

SEQ	LEN	DT	Usage	Card.	TBL#	ITEM#	Element name
1	4	SI	O	[1..1]		00104	Set ID - PID

IHE Pathology & Laboratory Medicine Technical Framework, Vol. 2x (PaLM TF-2x):
Transactions

SEQ	LEN	DT	Usage	Card.	TBL#	ITEM#	Element name
2	20	CX	X	[0..1]		00105	Patient ID
3	250	CX	R	[1..*]		00106	Patient Identifier List
4	20	CX	X	[0..1]		00107	Alternate Patient ID - PID
5	250	XPN	R	[1..*]		00108	Patient Name
6	250	XPN	O	[0..1]		00109	Mother's Maiden Name
7	26	TS	RE	[0..1]		00110	Date/Time of Birth
8	1	IS	R	[1..1]	0001	00111	Administrative Sex
9	250	XPN	X	[0..1]		00112	Patient Alias
10	250	CE	RE	[0..1]	0005	00113	Race
11	250	XAD	RE	[0..*]		00114	Patient Address
12	4	IS	X	[0..1]	0289	00115	County Code
13	250	XTN	O	[0..*]		00116	Phone Number - Home
14	250	XTN	O	[0..*]		00117	Phone Number - Business
15	250	CE	O	[0..1]	0296	00118	Primary Language
16	250	CE	O	[0..1]	0002	00119	Marital Status
17	250	CE	O	[0..1]	0006	00120	Religion
18	250	CX	RE	[0..1]		00121	Patient Account Number
19	16	ST	X	[0..1]		00122	SSN Number - Patient
20	25	DLN	X	[0..1]		00123	Driver's License Number - Patient
21	250	CX	O	[0..*]		00124	Mother's Identifier
22	250	CE	O	[0..1]	0189	00125	Ethnic Group
23	250	ST	O	[0..1]		00126	Birth Place
24	1	ID	O	[0..1]	0136	00127	Multiple Birth Indicator
25	2	NM	O	[0..1]		00128	Birth Order
26	250	CE	O	[0..1]	0171	00129	Citizenship
27	250	CE	O	[0..1]	0172	00130	Veterans Military Status
28	250	CE	X	[0..0]	0212	00739	Nationality
29	26	TS	O	[0..1]		00740	Patient Death Date and Time
30	1	ID	O	[0..1]	0136	00741	Patient Death Indicator
31	1	ID	RE	[0..1]	0136	01535	Identity Unknown Indicator
32	20	IS	RE	[0..1]	0445	01536	Identity Reliability Code
35	250	CE	C	[0..1]	0446	01539	Species Code
36	250	CE	C	[0..1]	0447	01540	Breed Code

1920 The specific usage of these fields, especially those fields with usage " O " (optional) in the table above, is explained in the national extensions.

PID-7 Date/Time of Birth (TS), required if known.

If the exact date of birth is not known, the second component of this field can be used to describe the degree of precision of the information entered in the first component.

PID-18 Patient Account Number (CX), required if known.

1925 The use of the Patient Account Number may be related to the Visit Number (PV1-19). Generally, one of both fields will be filled. Additional requirements for these fields may be documented in Regional or National appendices to the Technical Framework.

PID-35 Species Code (CE), PID-36 Breed Code (CE), conditional.

Condition predicate: shall be used if the test subject is a non-human living subject.

1930 C.4 PV1 – Patient Visit Segment

HL7 v2.5: chapter 3 (3.4.3)

The PV1 segment is used by Registration/Patient Administration applications to communicate information on an account or visit-specific basis.

Table C.4-1: PV1 - Patient Visit Segment

SEQ	LEN	DT	Usage	Card.	TBL#	ITEM#	Element name
2	1	IS	R	[1..1]	0004	00132	Patient Class
3	80	PL	RE	[0..1]		00133	Assigned Patient Location
9	250	XCN	X	[0..0]	0010	00139	Consulting Doctor
19	250	CX	RE	[0..1]		00149	Visit Number
40	1	IS	X	[0..0]	0116	00170	Bed Status
51	1	IS	C	[0..1]	0326	01226	Visit Indicator
52	250	XCN	X	[0..0]	0010	01274	Other Healthcare Provider

1935 The specific usage of these fields may be elaborated upon in the national extensions.

The use of the Visit Number (PV1-19) may be related to the Patient Account Number (PID-18). Generally, one of both fields will be filled. Additional requirements for these fields may be documented in Regional or National appendices to the Technical Framework.

1940 Field PV1-51 shall be valued with value 'V' if the field PV1-19 is present. The field may be omitted otherwise.

The PV1 segment doesn't entirely cover the data model as defined in this framework. In some countries (especially in Europe), national extensions will define new segment to manage issues like 'functional units'.

The use of the PV1 segment shall be clarified in each national extension.

1945 C.5 ORC – Common Order Segment

HL7 v2.5: chapter 4 (4.5.1). The ORC and OBR segments contain a number of duplicate fields. The Technical Framework is defined in such a way that fields in the OBR segment will be used in prevalence over their equivalents in ORC. If a field is listed as being optional in ORC, its equivalent in OBR may well be mandatory.

1950

Table C.5-1: ORC Segment

SEQ	LEN	DT	Usage	Card.	TBL #	ITEM#	Element name
1	2	ID	R	[1..1]	0119	00215	Order Control
2	22	EI	C	[0..1]		00216	Placer Order Number
3	22	EI	C	[0..1]		00217	Filler Order Number
4		EIP	RE	[0..1]		00218	Placer Group Number
5	2	ID	C	[0..1]	0038	00219	Order Status
6	1	ID	O	[0..1]	0121	00220	Response Flag
7	200	TQ	X	[0..0]		00221	Quantity/Timing
8	200	EIP	C	[0..1]		00222	Parent
9	26	TS	R	[1..1]		00223	Date/Time of Transaction
10	250	XCN	O	[0..*]		00224	Entered By
11	250	XCN	O	[0..*]		00225	Verified By
12	250	XCN	O	[0..1]		00226	Ordering Provider
13	80	PL	O	[0..1]		00227	Enterer's Location
14	250	XTN	O	[0..2]		00228	Call Back Phone Number
15	26	TS	O	[0..1]		00229	Order Effective Date/Time
16	250	CE	O	[0..1]		00230	Order Control Code Reason
17	250	CE	C	[0..1]		00231	Entering Organization
18	250	CE	O	[0..1]		00232	Entering Device
19	250	XCN	O	[0..*]		00233	Action By
20	250	CE	X	[0..0]	0339	01310	Advanced Beneficiary Notice Code
21	250	XON	O	[0..1]		01311	Ordering Facility Name
22	250	XAD	O	[0..1]		01312	Ordering Facility Address
23	250	XTN	O	[0..1]		01313	Ordering Facility Telephone Number
24	250	XAD	O	[0..1]		01314	Ordering Provider Address
25	250	CWE	X	[0..0]		01473	Order Status Modifier
26	60	CWE	X	[0..0]	0552	01641	Advanced Beneficiary Notice Override Reason
27	26	TS	C	[0..1]		01642	Filler's Expected Availability Date/Time
28	250	CWE	O	[0..1]		00615	Confidentiality Code
29	250	CWE	RE	[0..1]		01643	Order Type
30	250	CNE	O	[0..1]		01644	Enterer Authorization Mode
31	250	CWE	X	[0..1]		02286	Parent Universal Service Identifier

ORC-1 Order Control (ID), required.

This field may be considered the "trigger event" identifier for orders. Many order control codes are defined in the *HL7 table 0119 – Order Control Codes*. The Technical Framework allows only the following subset:

1955

Subset of HL7 table 0119 – Order Control Codes Supported by IHE

Value	Description of use
NW	“New Order”. Event request in OML message sent by the Order Placer in transaction LAB-1 or in OML message sent by the Order Filler in transaction LAB-4.
OK	“Notification or request accepted”. Event notification in OML message. Event acknowledgement in ORL message
UA	“Unable to accept order/service”. Event notification in OML message. Event acknowledgement in ORL message sent by the Order Filler in transaction LAB-1 or in ORL message sent by the Automation Manager in transaction LAB-4.
SC	“Status changed”. Event notification in OML, ORU and OUL messages
CA	“Cancel order/ service request”. Event request in OML message sent by the Order Placer in LAB-1, or by the Order Filler in LAB-4.
CR	“Canceled as requested”. Event acknowledgement in ORL message responding to OML (CA)
UC	“Unable to cancel”. Event acknowledgement in ORL message responding to OML (CA)
OC	“Order service canceled”. Event notification in OML message sent by the Order Filler in transactions LAB-1 and LAB-3.
SN	“Send order/service number”. Event request in OML message sent by the Order Filler in transaction LAB-2
NA	“Number assigned”. Event acknowledgement in ORL message sent by the Order Placer in LAB-2, responding to OML (SN)
RP	“Order/service replace request”. Event request in OML message sent by the Order Placer in transaction LAB-1 or in OML message sent by the Order Filler in transaction LAB-4.
RQ	“Replaced as requested”. Event acknowledgement in ORL message responding to OML (RQ)
UM	“Unable to replace”. Event acknowledgement in ORL message responding to OML (RQ)
RU	“Replaced unsolicited”. Event notification in OML message (LAB-1) and OUL message (LAB-3) sent by the Order Filler.
XO	“Change order/service request”. Used by the Order Placer in LAB-1
XR	“Changed as requested”. Used by the Order Filler in LAB-1 in response to XO
UX	“Unable to change” Used by the Order Filler in LAB-1 in response to XO
PR	“Previous results with new order/service”. Used in LAB-1, LAB-4, LAB-21 and LAB-22 to provide some previous results with the order or work order or wok order step that is requested by the sender.

ORC-2 Placer Order Number (EI), conditional.

The Placer Order Number (ORC-2, OBR-2) is local to the transaction: In transactions LAB-1, LAB-2, LAB-3 it is a number assigned to the Order by the Order Placer Actor. In transactions LAB-4, LAB-5 it is a number assigned to the Work Order by the Order Filler Actor. In transactions LAB-21, LAB-22, LAB-23 it is a number assigned to the WOS (Work Order Step) by the Automation Manager.

1960

Condition predicate: if the field is valued then its value shall match the value of the required field OBR-2.

ORC-3 Filler Order Number (EI), conditional.

Condition predicate: if the field is valued then its value shall match the value of the required field OBR-3.

1965

ORC-4 Placer Group Number (EIP), required if known to the sender.

The data type of ORC-4 is upgraded from EI to EIP, in pre-adoption of HL7 2.8.

1970 The Placer Group Number represents an identification of a set of closely related orders, i.e., a list of batteries and tests ordered together by the placer to the laboratory for one subject, known as an **Order Group**. This field carries the Order Group identification, which is a pair of identifiers. The first identifier, if present, is assigned by the Order Placer application. The second identifier, if present, is assigned by the Order Filler application.

1975 An Order Group may be identified by the order placer or by the order filler or by both applications. The Order Group consists of all the ORCs and order detail segments sharing the same Order Group identification.

In cases laboratory orders are not grouped under a common Order Group this field is empty.

1980 The Order Group identification is constant throughout the laboratory workflow once the Order Group has been accepted and registered in the Order Filler application. From that point the content of this field (one or two identifiers) should be constant across all messages related to an Order Group, circulating between Order Placer, Order Filler, Order Result Tracker, Automation Manager, Pre/post-processor, Analyzer Manager, Analyzer, Label Broker, Label Information Provider.

ORC-5 Order Status (ID), conditional.

1985 Condition predicate: This field shall be valued in all OML messages sent by the Order Filler. It represents the status of the order. This field shall not be valued in OML messages sent by the Order Placer.

The allowed values for this field within the Technical Framework are a subset of *HL7 table 0038 - Order Status*:

1990 **HL7 Table 0038 - Order Status: IHE Subset for all Transactions**

Value	Description	Comment
A	Some, but not all, results available	
CA	Order was canceled	
CM	Order is completed	
IP	In process, unspecified	
SC	In process, scheduled	

Note: For the conditions of use of these values, please read Section C.10 in Appendix C “Correlations of status between ORC, OBR and OBX”.

ORC-6 Response Flag (ID), optional.

1995 The Pathology and Laboratory Medicine Technical Framework does not constrain the usage of this field.

ORC-7 Quantity/Timing (TQ), not supported.

The Pathology and Laboratory Medicine Technical Framework does not support this field.

ORC-8 Parent (EIP), conditional.

HL7 definition: This field relates a child to its parent when a parent-child relationship exists.

2000 In this Technical Framework this field is used in the context of microbiology orders, in transactions LAB-2 and LAB-3. The Order Filler Actor uses this field to specify the parent order from which a child order was generated on the laboratory side.

Condition predicate: If this field is valued, its content must be the same as the content of OBR-29.

2005 **ORC-9 Date/Time of Transaction (TS)**, required.

HL7 Definition: This field contains the date and time of the event that initiated the current transaction as reflected in ORC-1 Order Control Code. This field is not equivalent to MSH-7 Date and Time of Message that reflects the date/time of the creation of the physical message.

2010 In OML messages "Status changed", this field contains the date/time of the last status change of the unit of work (ORC-5).

ORC-10 Entered By (XCN), optional.

HL7 definition: This field contains the identity of the person who actually keyed the request into the application. Note that this refers to the current transaction as reflected in ORC-1 Order Control Code. It provides an audit trail in case the request is entered incorrectly and the ancillary department needs to clarify the request. By local agreement, either the ID number or name component may be omitted.

2015 The Technical Framework does not constrain the usage of this field.

For a new order placed (ORC-1="NW"), the field specifies the person who typed the order on the Order Placer application.

2020 **ORC-11 Verified By (XCN)**, optional.

HL7 definition: This field contains the identity of the person who verified the accuracy of the entered request. Note that this refers to the current transaction as reflected in ORC-1 Order Control Code. It is used in cases where the request is entered by a technician and needs to be verified by a higher authority (e.g., a nurse). By local agreement, either the ID number or name component may be omitted.

2025 The Technical Framework does not constrain the usage of this field.

ORC-12 Ordering Provider (XCN), optional.

HL7 definition: This field contains the identity of the person who is responsible for creating the request (i.e., the ordering physician).

2030 If the field is valued then its value has to match the value of the required field OBR-16.

ORC-13 Enterer's Location (PL), optional.

2035 HL7 definition: This field specifies the location (e.g., nurse station, ancillary service location, clinic, floor) where the person who entered the request was physically located when the order was entered. Note that this refers to the current transaction as reflected in ORC-1 Order Control Code. Only those subcomponents relevant to enterer's location should be valued (commonly nursing unit; facility; building; floor). The person who entered the request is defined in ORC-10-entered by.

The Technical Framework does not further constrain the usage of this field, which contains location that is geographic data, not organizational data, as opposed to ORC-17.

2040 For a new order placed (ORC-1="NW"), the field specifies the location where this order was typed on the Order Placer application.

ORC-14 Callback Phone Number (XTN), optional.

HL7 definition: This field contains the telephone number to call for clarification of a request or other information regarding the order.

2045 Up to two phone numbers can be stored in this field. If the field is valued then its value has to match the value of field OBR-17.

ORC-15 Order Effective Date/Time (TS), optional.

HL7 definition: This field contains the date/time that the changes to the request took effect or are supposed to take effect.

2050 If the field is left empty, its value is assumed to be equal to that specified in ORC-9-date/time of transaction or MSH-7-date/time of message if the transaction date/time is empty.

The Technical Framework does not constrain the usage of this field.

ORC-16 Order Control Code Reason (CE), optional.

2055 HL7 definition: This field contains the explanation (either in coded or text form) of the reason for the order event described by the order control code (HL7 Table 0119).

The Technical Framework does not constrain the usage of this field.

ORC-17 Entering Organization (CE), conditional.

2060 HL7 definition: This field identifies the organization that the enterer belonged to at the time he/she enters/maintains the order, such as medical group or department. The person who entered the request is defined in ORC-10 -entered by.

IHE Condition predicate:

This field represents the medical organization or team (e.g., the cardiology department) who places a new order.

2065 It should be provided by the Order Placer in OML messages carrying new orders (ORC-1="NW") sent to the Order Filler, over transaction LAB-1.

It should be propagated by the Order Filler in all messages related to this order, sent to the Automation Manager over transaction LAB-4 as well as to the Order Result Tracker over transaction LAB-3.

ORC-18 Entering Device (CE), optional.

2070 HL7 definition: This field identifies the physical device (terminal, PC) used to enter the order.
The Technical Framework does not constrain the usage of this field.

ORC-19 Action By (XCN), optional.

2075 HL7 definition: This field contains the identity of the person who initiated the event represented by the corresponding order control code. For example, if the order control code is CA (cancel order request), this field represents the person who requested the order cancellation. This person is typically a care provider but may not always be the same as ORC-12 ordering provider.
The Technical Framework does not constrain the usage of this field.

ORC-20 Advanced Beneficiary Notice Code (CE), optional.

2080 HL7 definition: This field indicates the status of the patient's or the patient's representative's consent for responsibility to pay for potentially uninsured services.
The Technical Framework does not constrain the usage of this field.

ORC-21 Ordering Facility Name (XON), optional.

2085 HL7 definition: This field contains the name of the facility placing the order.
The facility (hospital, clinic, institution) placing the order shall be represented with at least these three components: 1st = Organization name. 7th = Identifier Type Code with the value "FI", which means "Facility ID" as stated by HL7 table n° 0203. 10th = Organization Identifier.

ORC-22 Ordering Facility Address (XAD), optional.

2090 HL7 definition: This field contains the address of the facility placing the order.
The Technical Framework does not constrain the usage of this field.

ORC-23 Ordering Facility Phone Number (XTN), optional.

2090 HL7 definition: This field contains the telephone number of the facility placing the order.
The Technical Framework does not constrain the usage of this field.

ORC-24 Ordering Provider (XAD), optional.

2095 HL7 definition: This field contains the address of the care provider requesting the order.
The Technical Framework does not constrain the usage of this field.

ORC-25 Order Status Modifier (CWE), optional.

HL7 definition: This field is a modifier or refiner of the ORC-5-Order status field. This field may be used to provide additional levels of specificity or additional information for the defined order

2100 status codes. Unlike the Order Status field, which is controlled by an HL7 defined table, this field is a CE data type allowing applications to support an unlimited library of Order Status Modifier codes.

The Technical Framework does not constrain the usage of this field.

ORC-26 Advanced Beneficiary Notice Override Reason (CWE), optional.

2105 HL7 definition: This field contains the reason why the patient did not sign an Advanced Beneficiary Notice. The reason may be coded or it may be a free text entry.

The Technical Framework does not constrain the usage of this field.

ORC-27 Fillers Expectable Availability Date/Time (TS), conditional.

This field contains the date/time when the laboratory results are planned to be available.

2110 Condition predicate: This field may be valued only in OML messages sent by the Order Filler to the Order Placer.

ORC-28 Confidentiality Code (CWE), optional.

HL7 definition: This field contains information about the level of security and/or sensitivity surrounding the order (e.g., highly sensitive, not sensitive, sensitive, etc.).

The Technical Framework does not constrain the usage of this field.

2115 **ORC-29 Order Type (CWE)**, required, may be empty.

HL7 definition: This field indicates whether the order is to be executed in an inpatient setting or an outpatient setting. If this field is not valued, the system default is assumed. Refer to HL7 Table 0482 – Order Type for suggested values:

HL7 Table 0482 - Order Type

Value	Description	Comment
I	Inpatient Order	
O	Outpatient Order	

2120 Field ORC-29 enables to distinguish between orders related to inpatient activity or outpatient activity, independently of the real situation of the patient expressed in PV1. This field should be populated if known in messages sent by the Order Placer to the Order Filler, and propagated by the latter to the Automation Manager and to the Order Result Tracker.

ORC-30 Enterer Authorization Mode (CNE), optional.

2125 HL7 definition: This field indicates the form of authorization a recorder had from the responsible practitioner to create or change an order.

The Technical Framework does not constrain the usage of this field.

ORC-31 Parent Universal Service Identifier (CWE), not supported.

2130 This field contains the identifier code for the parent order, which caused this observation/test/battery to be performed. Its content is the same as the one of OBR-50 ORC-31 and OBR-50 will be deprecated in version 2.7 of the standard.

C.6 TQ1 – Timing Quantity Segment

HL7 v2.5: chapter 4 (4.5.4)

Table C.6-1: TQ1 - Timing Quantity Segment

SEQ	LEN	DT	Usage	Card.	TBL #	ITEM#	Element name
7	26	TS	C	[0..1]		01633	Start date/time
9	250	CWE	R	[1..1]	0485	01635	Priority
12	10	ID	X	[0..0]	0427	01638	Conjunction

2135

The IHE Technical Framework does not use TQ2 segment, and uses only one occurrence of TQ1 segment.

TQ1-7 Start date/time (TS), conditional.

2140 HL7 definition: This field may be specified by the requester, in which case it indicates the earliest date/time at which the services should be started. In many cases, however, the start date/time will be implied or will be defined by other fields in the service request record (e.g., urgency - STAT). In such a case, this field will be empty.

2145 Condition predicate: This field is used in messages from the requester to the filler (Order Placer to Order Filler in LAB-1, Order Filler to Automation Manager in LAB-4, Automation Manager to LD in LAB-21 and LAB-22) in cases where the requester wants to enforce a starting date/time for the execution of the ordered tests.

2150 As an example, if an order is placed with the specimen collection scheduled to be performed by a placer staff tomorrow morning, field TQ1-7 will be populated with this scheduled collection time so that the order filler knows that this order will not start until that time and no specimen is to be expected until then.

TQ1-9 Priority (CWE), required.

This field defines the priority of the order. The values authorized by the Technical Framework are this subset of HL7 table 0485 - Priority codes:

HL7 Table 0485 - Priority Codes

Value	Description	Comment
S	Stat	With highest priority
A	ASAP	Fill after S orders

Value	Description	Comment
R	Routine	Default
P	Preop	
C	Callback	
T	Timing critical	A request implying that it is critical to come as close as possible to the requested time, e.g., for a trough anti-microbial level.

2155

Note: Transactions LAB-1, LAB-2 and LAB-3 restrict the usage to the first 6 values: S, A, R, P, C, T

TQ1-12 Conjunction (ID), not supported.

This field is conditional in HL7: It has to be valued only in case there is more than one TQ1 segment. As this IHE Framework restricts TQ1 to one single occurrence this field shall never be valued.

2160

C.7 SPM – Specimen Segment

HL7 v2.5: chapter 7 (7.4.3)

Table C.7-1: SPM - Specimen Segment

SEQ	LEN	DT	Usage	Card.	TBL #	ITEM#	Element name
1	4	SI	R	[1..1]		01754	Set ID – SPM
2	80	EIP	RE	[0..1]		01755	Specimen ID
3	80	EIP	RE	[0..*]		01756	Specimen Parent IDs
4	250	CWE	R	[1..1]	0487	01900	Specimen Type
5	250	CWE	O	[0..1]	0541	01757	Specimen Type Modifier
6	250	CWE	O	[0..*]	0371	01758	Specimen Additives
7	250	CWE	RE	[0..1]	0488	01759	Specimen Collection Method
8	250	CWE	RE	[0..1]		01901	Specimen Source Site
9	250	CWE	RE	[0..*]	0542	01760	Specimen Source Site Modifier
10	250	CWE	RE	[0..1]	0543	01761	Specimen Collection Site
11	250	CWE	RE	[0..*]	0369	01762	Specimen Role
12	20	CQ	X	[0..0]		01902	Specimen Collection Amount
13	6	NM	X	[0..0]		01763	Grouped Specimen Count
14	250	ST	O	[0..*]		01764	Specimen Description
15	250	CWE	O	[0..*]	0376	01908	Specimen Handling Code
16	250	CWE	RE	[0..1]	0489	01903	Specimen Risk Code
17	26	DR	RE	[0..1]		01765	Specimen Collection Date/Time
18	26	TS	C	[0..1]		00248	Specimen Received Date/Time
19	26	TS	O	[0..1]		01904	Specimen Expiration Date/Time
20	1	ID	C	[0..1]	0136	01766	Specimen Availability
21	250	CWE	C	[0..*]	0490	01767	Specimen Reject Reason

SEQ	LEN	DT	Usage	Card.	TBL #	ITEM#	Element name
22	250	CWE	O	[0..1]	0491	01768	Specimen Quality
23	250	CWE	O	[0..1]	0492	01769	Specimen Appropriateness
24	250	CWE	O	[0..*]	0493	01770	Specimen Condition
25	20	CQ	O	[0..1]		01771	Specimen Current Quantity
26	4	NM	RE	[0..1]		01772	Number of Specimen Containers
27	250	CWE	C	[0..1]		01773	Container Type
28	250	CWE	O	[0..1]	0544	01774	Container Condition
29	250	CWE	O	[0..1]	0494	01175	Specimen Child Role

SPM-1 Set ID – SPM (SI), required.

2165 This field is used to identify SPM segment instances in messages where the SPM segment repeats. For the first (or only) occurrence of the segment, the sequence number is |1|; for the second occurrence, the sequence number is |2|; etc.

SPM-2 Specimen ID (EIP), required if available.

This field contains a unique identifier or pair of unique identifiers for the specimen, enterprise-wide.

2170 The transactions of profiles LAW and LBL use only the 1st component of data type EIP.

SPM-3 Specimen Parent ID (EIP), required if available.

This field contains the identifier for the parent specimen, from which the specimen described by the segment instance has been extracted.

The transactions of profiles LAW and LBL use only the 1st component of data type EIP.

2175 **SPM-4 Specimen Type (CWE), required.**

This field describes the precise nature of the entity that will be the source material for the observations. Valid coding systems for this field include HL7 table 0487 listed below, SNOMED CT, or any national coding scheme.

HL7 Table 0487

Value	Description	Comment
ABS	Abscess	
AMN	Amniotic fluid	
ASP	Aspirate	
BIFL	Bile fluid	
BLDA	Blood arterial	
BBL	Blood bag	
BLDC	Blood capillary	
BPU	Blood product unit	

Value	Description	Comment
BLDV	Blood venous	
BON	Bone	
BRO	Bronchial	
BRN	Burn	
CALC	Calculus (=Stone)	
CDM	Cardiac muscle	
CNL	Cannula	
CTP	Catheter tip	
CSF	Cerebral spinal fluid	
CVM	Cervical mucus	
CVX	Cervix	
COL	Colostrum	
BLDCO	Cord blood	
CNJT	Conjunctiva	
CUR	Curettage	
CYST	Cyst	
DIAF	Dialysis fluid	
DOSE	Dose med or substance	
DRN	Drain	
DUFL	Duodenal fluid	
EAR	Ear	
EARW	Ear wax (cerumen)	
ELT	Electrode	
ENDC	Endocardium	
ENDM	Endometrium	
EYE	Eye	
EXG	Exhaled gas (=breath)	
FLT	Filter	
FIST	Fistula	
FLU	Body fluid, unsp	
GAS	Gas	
GAST	Gastric fluid/contents	
GEN	Genital	
GENC	Genital cervix	
GENL	Genital lochia	
GENV	Genital vaginal	
HAR	Hair	
IHG	Inhaled Gas	
IT	Intubation tube	

Value	Description	Comment
ISLT	Isolate	
LAM	Lamella	
LN	Line	
LNA	Line arterial	
LNV	Line venous	
LIQ	Liquid NOS	
MAR	Marrow	
MEC	Meconium	
MBLD	Menstrual blood	
MLK	Milk	
MILK	Breast milk	
NAIL	Nail	
NOS	Nose (nasal passage)	
ORH	Other	
PAFL	Pancreatic fluid	
PRT	Peritoneal fluid /ascites	
PLC	Placenta	
PLAS	Plasma	
PLB	Plasma bag	
PLR	Pleural fluid (thoracentesis fld)	
PPP	Platelet poor plasma	
PRP	Platelet rich plasma	
PUS	Pus	
RT	Route of medicine	
SAL	Saliva	
SMN	Seminal fluid	
SER	Serum	
SKN	Skin	
SKM	Skeletal muscle	
SPRM	Spermatozoa	
SPT	Sputum	
SPTC	Sputum - coughed	
SPTT	Sputum - tracheal aspirate	
STL	Stool = Fecal	
SWT	Sweat	
SNV	Synovial fluid (Joint fluid)	
TEAR	Tears	
THRT	Throat	
TISS	Tissue	

Value	Description	Comment
TISG	Tissue gall bladder	
TLGI	Tissue large intestine	
TLNG	Tissue lung	
TISPL	Tissue placenta	
TSMI	Tissue small intestine	
TISU	Tissue ulcer	
TUB	Tube NOS	
ULC	Ulcer	
UMB	Umbilical blood	
UMED	Unknown medicine	
URTH	Urethra	
UR	Urine	
URC	Urine clean catch	
URT	Urine catheter	
URNS	Urine sediment	
USUB	Unknown substance	
VITF	Vitreous Fluid	
VOM	Vomitus	
BLD	Whole blood	
BDY	Whole body	
WAT	Water	
WICK	Wick	
WND	Wound	
WNDA	Wound abscess	
WNDE	Wound exudate	
WNDD	Wound drainage	

2180 **SPM-5 Specimen Type Modifier (CWE)**, optional.

This field contains modifying or qualifying description(s) about the specimen type whenever the vocabulary used in SPM-4 lacks of precision.

SPM-6 Specimen Additives (CWE), optional, repeatable.

2185 HL7 definition: This field identifies any additives introduced to the specimen before or at the time of collection. These additives may be introduced in order to preserve, maintain or enhance the particular nature or component of the specimen.

The Technical Framework has not constrained the usage of this field yet, other than adopting HL7 table 0371 for valid values:

HL7 Table 0371 – Additive/Preservative

Value	Description	Comment
F10	10% Formalin	Tissue preservative
C32	3.2% Citrate	Blue top tube
C38	3.8% Citrate	Blue top tube
HCL6	6N HCL	24 HR Urine Additive
ACDA	ACD Solution A	Yellow top tube
ACDB	ACD Solution B	Yellow top tube
ACET	Acetic Acid	Urine preservative
AMIES	Amies transport medium	Protozoa
HEPA	Ammonium heparin	Green top tube
BACTM	Bacterial Transport medium	Microbiological culture
BOR	Borate Boric Acid	24HR Urine Additive
BOUIN	Bouin's solution	Tissue
BF10	Buffered 10% formalin	Tissue
WEST	Buffered Citrate (Westergren Sedimentation Rate)	Black top tube
BSKM	Buffered skim milk	Viral isolation
CARS	Carson's Modified 10% formalin	Tissue
CARY	Cary Blair Medium	Stool Cultures
CHLTM	Chlamydia transport medium	Chlamydia culture
CTAD	CTAD (this should be spelled out if not universally understood)	Blue top tube
ENT	Enteric bacteria transport medium	Bacterial culture
ENT+	Enteric plus	Stool Cultures
JKM	Jones Kendrick Medium	Bordetella pertussis
KARN	Karnovsky's fixative	Tissue
LIA	Lithium iodoacetate	Gray top tube
HEPL	Lithium/Li Heparin	Green top tube
M4	M4	Microbiological culture
M4RT	M4-RT	Microbiological culture
M5	M5	Microbiological culture
MICHTM	Michel's transport medium	IF tests
MMDTM	MMD transport medium	Immunofluorescence
HNO3	Nitric Acid	Urine
NONE	None	Red or Pink top tube
PAGE	Pages's Saline	Acanthoemba
PHENOL	Phenol	24 Hr Urine Additive
KOX	Potassium Oxalate	Gray top tube
<u>EDTK</u>	<u>Potassium/K EDTA</u>	<u>Deprecated. Replaced by EDTK15 and EDTK75</u>

Value	Description	Comment
EDTK15	Potassium/K EDTA 15%	Purple top tube
EDTK75	Potassium/K EDTA 7.5%	Purple top tube
PVA	PVA (polyvinylalcohol)	O&P
RLM	Reagan Lowe Medium	Bordetella pertussis cultures
SST	Serum Separator Tube (Polymer Gel)	'Tiger' Top tube
SILICA	Siliceous earth, 12 mg	Gray top tube
NAF	Sodium Fluoride	Gray top tube
FL100	Sodium Fluoride, 100mg	Urine
FL10	Sodium Fluoride, 10mg	Urine
NAPS	Sodium polyanethol sulfonate 0.35% in 0.85% sodium chloride	Yellow (Blood Culture)
HEPN	Sodium/Na Heparin	Green top tube
EDTN	Sodium/Na EDTA	Dark Blue top tube
SPS	SPS(this should be spelled out if not universally understood)	Anticoagulant w/o bacteriocidal properties
STUTM	Stuart transport medium	Bacterial culture
THROM	Thrombin	Orange or Grey/Yellow (STAT Chem)
FDP	Thrombin NIH; soybean trypsin inhibitor (Fibrin Degradation Products)	Dark Blue top tube
THYMOL	Thymol	24 Hr Urine Additive
THYO	Thyoglycollate broth	Bacterial Isolation
TOLU	Toluene	24 Hr Urine Additive
URETM	Ureaplasma transport medium	Ureaplasma culture
VIRTM	Viral Transport medium	Virus cultures

2190 **SPM-7 Specimen Collection Method (CWE)**, required if available.

This field describes the procedure or process by which the specimen was collected. Valid coding systems for this field include HL7 table 0488 listed below, SNOMED CT, or any national coding scheme.

HL7 Table 0488 – Specimen Collection Method

Value	Description	Comment
FNA	Aspiration, Fine Needle	
PNA	Aterial puncture	
BIO	Biopsy	
BCAE	Blood Culture, Aerobic Bottle	
BCAN	Blood Culture, Anaerobic Bottle	
BCPD	Blood Culture, Pediatric Bottle	

Value	Description	Comment
CAP	Capillary Specimen	
CATH	Catheterized	
EPLA	Environmental, Plate	
ESWA	Environmental, Swab	
LNA	Line, Arterial	
CVP	Line, CVP	
LNV	Line, Venous	
MART L	Martin-Lewis Agar	
ML11	Mod. Martin-Lewis Agar	
PACE	Pace, Gen-Probe	
PIN	Pinworm Prep	
KOFF P	Plate, Cough	
MLP	Plate, Martin-Lewis	
NYP	Plate, New York City	
TMP	Plate, Thayer-Martin	
ANP	Plates, Anaerobic	
BAP	Plates, Blood Agar	
PRIM E	Pump Prime	
PUMP	Pump Specimen	
QC5	Quality Control For Micro	
SCLP	Scalp, Fetal Vein	
SCRA PS	Scrapings	
SHA	Shaving	
SWA	Swab	
SWD	Swab, Dacron tipped	
WOO D	Swab, Wooden Shaft	
TMOT	Transport Media,	
TMAN	Transport Media, Anaerobic	
TMCH	Transport Media, Chlamydia	
TMM4	Transport Media, M4	
TMM Y	Transport Media, Mycoplasma	
TMPV	Transport Media, PVA	
TMSC	Transport Media, Stool Culture	

Value	Description	Comment
TMUP	Transport Media, Ureaplasma	
TMVI	Transport Media, Viral	
VENIP	Venipuncture	

2195 **SPM-8 Specimen Source Site (CWE)**, required if available.

This field should be populated, particularly in microbiology, both in order and result messages when the specimen source site is known. Example: “EAR”.

SPM-9 Specimen Source Site Modifier (CWE), required if available, repeatable.

2200 This field should be populated, particularly in microbiology, both in order and result messages when the specimen source site modifier is known. Example: “LEFT” when the specimen has been collected from the left ear. More than one source site modifier may be populated.

SPM-10 Specimen Collection Site (CWE), required if available.

2205 **HL7 definition:** This field differs from SPM-8-Specimen Source Site in those cases where the source site must be approached via a particular site (e.g., anatomic location). For example, in the case where a liver biopsy is obtained via a percutaneous needle, the collection site would be the point of entry of the needle. For venous blood collected from the left radial vein, the collection site could be “antecubital fossa”.

The Technical Framework leaves the usage of this field with no pre-specified vocabulary. HL7 user defined Table 0453 does not suggest any values.

2210 **SPM-11 Specimen Role (CWE)**, required if known by the sender, repeatable.

The allowed values are listed in HL7 user defined table 0369, complemented by IHE:

HL7 User-Defined Table 0369 – Specimen Role

Value	Description	Comment
B	Blind Sample	
C	Calibrator, used for initial setting of calibration	
E	Electronic QC, used with manufactured reference providing signals that simulate QC results	
F	Specimen used for testing proficiency of the organization performing the testing (Filler)	
G	Group (where a specimen consists of multiple individual elements that are not individually identified)	
L	Pool (aliquots of individual specimens combined to form a single specimen representing all of the components.)	
O	Specimen used for testing Operator Proficiency	
P	Patient (human or other species)	

Value	Description	Comment
Q	Control specimen	
R	Replicate	
V	Verifying Calibrator, used for periodic calibration checks	
PSN	Human patient	added by IHE LAB TF, taken from HL7 V3 vocab
ANM	Animal	added by IHE LAB TF, taken from HL7 V3 vocab
MIC	Microorganism	added by IHE LAB TF, taken from HL7 V3 vocab
PLNT	Plant	added by IHE LAB TF, taken from HL7 V3 vocab
MAT	Material, non-living subject	added by IHE LAB TF, taken from HL7 V3 vocab

Restricted value sets:

2215 Transactions LAB-1, LAB-2 and LAB-3 deal with orders and results basically related to specimens collected from a patient and in some cases specimens collected from a non-person or even non-living subject (suspected rabid fox, spoiled water, rotten meat, isolated microorganism...) Therefore in these transactions, the only valid values are: “P” (patient, human or not), “PSN” (human patient), “ANM” (animal), “MIC” (microorganism subject), “PLNT” (vegetable subject), “MAT” (non-living subject e.g., air, water, instrument, food...)

2220 Transactions LAB-4 and LAB-5 use the same value set as LAB-1, LAB-2 and LAB-3, plus one extra value: “Q” (control specimen) used on Work Orders and results related to quality control specimens.

The other transactions of the Technical Framework using the SPM segment use the values in the table above, with no particular restriction.

2225 **SPM-12 Specimen Collection Amount (CQ)**, not supported.

HL7 definition: This field specifies the volume (quantity and units) of the collected specimen. The field has two components: <Quantity (NM)>^<Units (CE)>

The Technical Framework in its current release does not use this field.

2230 In particular, the volume of a 24-hour urine specimen is carried in the OML message placing the Order (or the Work Order) as an observation in itself, using one or two OBX segments, as in the example below:

```
SPM|2|654_2^chemistry||UR|||||P|||||200310060735|200310060821||Y|||||1
OBX|1|NM|13362-9^URINE COLLECTION DURATION^LN||24|Hr|||||F|||200309060735
OBX|2|NM|19153-6^URINE SPECIMEN VOLUME^LN||980|ml|||||F|||200309060735
```

2235 **SPM-13 Grouped Specimen Count (NM)**, not supported.

The Technical Framework in its current release does not use this field, since none of its Transaction deals with grouped specimens.

SPM-14 Specimen Description (ST), optional.

2240 HL7 definition: This is a text field that allows additional information specifically about the specimen to be sent in the message.

In the LBL Profile, this field may be used to carry additional items of information about the specimen, which are not related to any other of the SPM fields, and which need to appear on the printed labels (i.e., particular specimen treatment requirements). The sender can produce as many instances of SPM-14 as there are information items to transfer to the label.

2245 The Technical Framework has not constrained the usage of this field yet.

SPM-15 Specimen Handling Code (CWE), optional, repeatable.

HL7 definition: This field describes how the specimen and/or container need to be handled from the time of collection through the initiation of testing.

2250 This field may be used in messages placing an Order (in LAB-1) or a Work Order (in LAB-4) or a Work Order Step (in LAB-21 and LAB-22) as well as in messages carrying labeling instructions (in LAB-61 and LAB-62).

The allowed values are listed in HL7 user defined table 0369, complemented by IHE:

HL7 User-Defined Table 0376 – Specimen Handling Code

Code	Description	Comment/Usage Note/Definition
C37	Body temperature	Critical to keep at body temperature: 36 - 38° C.
AMB	Ambient temperature	Keep at ambient (room) temperature, approximately 22 ± 2 degrees C. Accidental refrigeration or freezing is of little consequence
CAMB	Critical ambient temperature	Critical ambient – must not be refrigerated or frozen.
REF	Refrigerated temperature	Keep at refrigerated temperature: 4-8° C. Accidental warming or freezing is of little consequence
CREF	Critical refrigerated temperature	Critical refrigerated – must not be allowed to freeze or warm until immediately prior to testing
FRZ	Frozen temperature	Keep at frozen temperature: -4° C. Accidental thawing is of little consequence
CFRZ	Critical frozen temperature	Critical frozen – must not be allowed to thaw until immediately prior to testing
DFRZ	Deep frozen	Deep frozen: -16 to -20° C.
UFRZ	Ultra frozen	Ultra cold frozen: ~ -75 to -85° C. (ultra cold freezer is typically at temperature of dry ice).
NTR	Liquid nitrogen	Keep in liquid nitrogen.
PRTL	Protect from light	Protect from light (e.g., wrap in aluminum foil).
CATM	Protect from air	Critical. Do not expose to atmosphere. Do not uncap.
DRY	Dry	Keep in a dry environment.
PSO	No shock	Protect from shock.
PSA	Do not shake	Do not shake.

Code	Description	Comment/Usage Note/Definition
UPR	Upright	Keep upright. Do not turn upside down.
MTLF	Metal Free	Container is free of heavy metals including lead.

SPM-16 Specimen Risk Code (CWE), required if available.

2255 This field contains any known or suspected specimen hazards.

Condition predicate: This field shall be populated if known in OML messages sent by the Order Placer, within transaction LAB-1, and OML messages sent by the Order Filler within transactions LAB-2 and LAB-4. The allowed values are given by HL7 user-defined table 0489:

HL7 User-Defined Table 0489 – Risk Codes

Code	Description	Comment/Usage Note/Definition
BIO	Biological	The dangers associated with normal biological materials (i.e., potential risk of unknown infections). Routine biological materials from living subjects.
COR	Corrosive	Material is corrosive and may cause severe injury to skin, mucous membranes and eyes. Avoid any unprotected contact.
ESC	Escape Risk	The entity is at risk for escaping from containment or control.
AGG	Aggressive	A danger that can be associated with certain living subjects, including humans.
IFL	MaterialDangerInflammable	Material is highly inflammable and in certain mixtures (with air) may lead to explosions. Keep away from fire, sparks and excessive heat.
EXP	Explosive	Material is an explosive mixture. Keep away from fire, sparks, and heat.
INF	MaterialDangerInfectious	Material known to be infectious with human pathogenic microorganisms. Those who handle this material must take precautions for their protection.
BHZ	Biohazard	Material contains microorganisms that are an environmental hazard. Must be handled with special care.
INJ	Injury Hazard	Material is solid and sharp (e.g., cannulas.) Dispose in hard container.
POI	Poison	Material is poisonous to humans and/or animals. Special care must be taken to avoid incorporation, even of small amounts.
RAD	Radioactive	Material is a source for ionizing radiation and must be handled with special care to avoid injury of those who handle it and to avoid environmental hazards.

2260 **SPM-17 Specimen Collection Date/Time (DR)**, required if available.

Definition: The date and time when the specimen was acquired from the source. The use of the Date Range data type allows for description of specimens collected over a period of time, for example, 24-hour urine collection. For specimens collected at a point in time, only the first component (start date/time) will be populated

2265 **SPM-18 Specimen Received Date/Time (TS)**, conditional.

The time that the specimen is received at the laboratory.

2270 Condition predicate: This field shall be populated in OML messages sent by the Order Filler, within transactions LAB-1 (all use cases), LAB-2 and LAB-3, if the specimen has been received by the laboratory. In other words this field is RE for the Order Filler Actor in both transactions LAB-1, LAB-2 and LAB-3.

SPM-19 Specimen Expiration Date/Time (TS), optional.

HL7 definition: This field is the date and time the specimen can no longer be used for the purpose implied by the order.

The Technical Framework has not constrained the usage of this field yet.

2275 **SPM-20 Specimen Availability (ID)**, conditional.

This describes whether the specimen, as it exists, is currently available to use in an analysis. The two authorized values are "Y" (yes) or "N" (no).

2280 Condition predicate: This field shall be populated in messages sent by the Order Filler, within transactions LAB-1, LAB-2 and LAB-3. The value 'N' indicates either that the laboratory hasn't received the specimen yet, or that it has rejected the received specimen.

The value of this field can be implicitly derived from ORC-5 (e.g., ORC-5 = 'IP' implicitly means that the specimen has arrived, otherwise the test could not be in progress).

If SPM-20 = "N" and ORC-5 is empty or valued with "SC" this means that the specimen has not been received yet. In that case SPM-21 is empty.

2285 If SPM-20 = "N" and ORC-5 is valued with "CA" this means that the specimen has been rejected by the laboratory and the related Order(s) canceled. SPM-21 must be valued with a reject reason.

SPM-21 Specimen Reject Reason (CWE), conditional, repeatable.

This field describes one or more reasons the specimen is rejected for the ordered batteries.

2290 Condition predicate: This field shall be populated whenever the laboratory rejects a specimen, .in OML messages sent by the Order Filler in transaction LAB-1, as well as in ORU or OUL messages sent by the Order Filler in transaction LAB-3.

HL7 Table 0490 lists valid values:

HL7 Table 0490 – Specimen Reject Reason

Value	Description	Comment
EX	Expired	
QS	Quantity not sufficient	
RB	broken container	
RC	Clotting	
RD	missing collection date	
R	missing patient ID number	

Value	Description	Comment
RE	missing patient name	
RH	Hemolysis	
RI	Identification problem	
RL	Improper labeling	
RM	labeling	
RN	contamination	
RP	missing phlebotomist ID	
RR	improper storage	
RS	name misspelling	

2295 In case a reject reason is not coded, only SPM-21.2 is populated with the reason in a free text format.

SPM-22 Specimen Quality (CWE), optional.

HL7 definition: The degree or grade of excellence of the specimen at receipt. The filler populates this attribute.

The Technical Framework has not constrained the usage of this field yet.

2300 **SPM-23 Specimen Appropriateness (CWE), optional.**

HL7 Definition: The suitability of the specimen for the particular planned use as determined by the filler.

The Technical Framework has not constrained the usage of this field yet.

SPM-24 Specimen Condition (CWE), optional, repeatable.

2305 HL7 definition: A mode or state of being that describes the nature of the specimen.

The Technical Framework has not constrained the usage of this field yet.

SPM-25 Specimen Current Quantity (CQ), optional.

HL7 definition: This attributes contains the amount of specimen that currently exists or is available for use in further testing.

2310 The Technical Framework has not constrained the usage of this field yet.

SPM-26 Number of Specimen Containers (NM), required if available.

HL7 Definition: This field identifies the number of containers for a given specimen. For sample receipt verification purposes; may be different from the total number of specimens that accompany the order.

2315 Example: One 24 Hr urine specimen collected in two bottles.

SPM-27 Container Type (CWE), conditional.

The container(s) on or in which a specimen is transported.

Condition predicate:

2320 This field shall be populated in ORL messages of transaction LAB-1, in the context of the use case "Order placed with specimens identified by a third party" defined in volume 1, when the third party is the Order Filler application.

This field shall be populated by the Label Information Provider in RSP messages of transaction LAB-62 and in OML messages of transaction LAB-61.

2325 The Technical Framework does not further constrain the usage of this field, nor does it provide any preferred vocabulary for it. This can be done in national extensions of this framework.

SPM-28 Container Condition (CWE), optional.

HL7 definition: This attributes contains the amount of specimen that currently exists or is available for use in further testing.

2330 The Technical Framework does not constrain the usage of this field yet, nor provides any preferred vocabulary for it.

SPM-29 Specimen Child Role (CWE), optional.

2335 HL7 Definition: For child specimens, this field identifies the relationship between this specimen and the parent specimen. If this field is populated, then SPM-3-Specimen Parent ID must be populated. This field differs from SPM-15-Specimen Role in that this field refers to the role of this specimen relative to a parent role rather than the role of this specimen to the ordered service.

The Technical Framework does not constrain the usage of this field yet.

C.8 SAC – Container Detail Segment

2340 HL7 v2.5: chapter 13

The Technical Framework uses some of the fields of the SAC segment listed below. It allows all other fields to be optionally used, except those superseded by fields of the SPM segment.

Table C.8-1: SAC Segment

SEQ	LEN	DT	Usage	Card.	TBL #	ITEM#	Element name
3	80	EI	RE	[0..1]		01331	Container Identifier
4	80	EI	C	[0..1]		01332	Primary (parent) Container Identifier
6	300	SPS	X	[0..0]		00249	Specimen Source
10	80	EI	O	[0..1]		01337	Carrier Identifier
11	80	NA	O	[0..1]		01338	Position in Carrier
13	80	EI	O	[0..1]		01340	Tray Identifier
14	80	NA	O	[0..1]		01341	Position in Tray
15	250	CE	O	[0..*]		01342	Location
26	250	CE	RE	[0..1]		01353	Cap Type

SAC-3 Container Identifier (EI), required if available.

2345 SAC-3 field identifies the container. This field is the container's identifier assigned by the corresponding equipment. A container may contain the primary (original) specimen or an aliquot (secondary sample) of that specimen. For primary sample this field contains Primary Container ID; for bar-coded aliquot samples this field contains Aliquot Container ID.

SAC-4 Primary (parent) Container Identifier (EI), conditional.

2350 Condition predicate: This field is used in transactions LAB-4 and LAB-5, LAB-21, LAB-22, LAB-23, LAB-26, LAB-61 and LAB-62 when dealing with an aliquot specimen. It is also used in transactions LAB-61, LAB-62 and LAB-63 in case more than one tube or label for the same specimen has to be printed or confirmed. In all these cases, SAC-3 and SAC-4 are used simultaneously as described below:

2355 If SAC-4 field is filled in, it identifies the primary container from which this specimen came. For primary specimens this field is empty; for aliquot specimens this field should contain the identifier of the primary container.

SAC-6 Specimen Source (SPS), not supported.

This field is superseded by the SPM segment.

2360 **SAC-10 Carrier Identifier (EI)**, optional.

HL7 definition: This field identifies the carrier. It is the ID (e.g., number or bar code) of the carrier where the container (e.g., tube) is located.

The Technical Framework has not constrained the usage of this field yet.

SAC-11 Position in Carrier (NA), optional.

2365 Components: <Value1 (NM)> ^ <Value2 (NM)> ^ <Value3 (NM)> ^ <Value4 (NM)> ^ < ()>

HL7 definition: This field identifies the position of the container in the carrier (e.g., 1...3...). The sub-components allow, if necessary, to transfer multiple axis information, e.g., 2-dimensional carrier (X^Y).

The Technical Framework has not constrained the usage of this field yet.

2370 **SAC-13 Tray Identifier (EI)**, optional.

HL7 definition: This field identifies the tray identifier (e.g., a number of a tray or a bar code on the tray), where the container carrier is located.

The Technical Framework has not constrained the usage of this field yet.

SAC-14 Position in Tray (NA), optional.

2375 Components: <Value1 (NM)> ^ <Value2 (NM)> ^ <Value3 (NM)> ^ <Value4 (NM)> ^ < ()>

HL7 definition: This field identifies the position of the carrier in the tray. The sub-components allow, if necessary, to transfer multiple axis information, e.g., 2-dimensional tray (X^Y).

The Technical Framework has not constrained the usage of this field yet.

SAC-15 Location (CE), optional.

2380 HL7 definition: This field is the physical location that the specimen was at the time that the transaction was initiated. The location description can vary with the LAS. For example, it can be an X, Y, Z coordinate in a storage system; a refrigerator number and drawer number where the container-carrier-tray is located; or it can be the name of the institution and the laboratory which owns the container currently. The repeating of this field allows for hierarchical representation of
2385 location (lowest level first), e.g., shelf number, refrigerator storage id, lab name, institution name, etc.

The Technical Framework has not constrained the usage of this field yet.

General rules concerning the communication of specimen id and container id:

2390 In all IHE LAB profiles, when a message references a primary specimen identified and labeled, the identifier (e.g., bar-coded) appearing on the label represents the content of field SPM-2.

2395 In IHE LAB profiles handling workflows between the clinical laboratory and external parties (LTW, LBL, ILW, LPOCT), the specimen identifier is identical to the identifier appearing (e.g., bar coded) on the container that holds this specimen. The proper field to carry this identifier in these profiles is SPM-2 “Specimen identifier”.

In IHE LAB profiles handling automated workflows internal to the clinical laboratory (LDA, LAW), the SAC segment is required and carries the “specimen in container” identification.

SAC-26 Cap Type (CE), required if available.

2400 HL7 definition: This field indicates the type of cap that is to be used with this container for decapping, piercing or other mechanisms.

Specific usage in the LBL Profile: This field shall be populated in OML_O33 and RSP_K11 messages, sent by the Label Information Provider (LIP) Actor if the SAC segment is present. The presence of the SAC segment means that the LIP has issued the LB to print additional labels for the same specimen, and the SAC-26 field will contain a code identifying the cap type of the tubes where the additional labels will be applied.

2405

C.9 OBX - Observation/Result Segment

HL7 v2.5.1: chapter 7 (7.4.2)

Table C.9-1: OBX Segment

SEQ	LEN	DT	Usage	Card.	TBL#	ITEM#	Element name
1	4	SI	R	[1..1]		00569	Set ID – OBX
2	2	ID	C	[0..1]	0125	00570	Value Type
3	250	CE	R	[1..1]		00571	Observation Identifier
4	20	ST	C	[0..1]		00572	Observation Sub-ID
5	99999	Varies	C	[0..1]		00573	Observation Value
6	250	CE	C	[0..1]		00574	Units
7	60	ST	RE	[0..1]		00575	References Range
8	5	IS	RE	[0..*]	0078	00576	Abnormal Flags
9	5	NM	X	[0..0]		00577	Probability
10	2	ID	X	[0..0]	0080	00578	Nature of Abnormal Test
11	1	ID	R	[1..1]	0085	00579	Observation Result Status
12	26	TS	X	[0..0]		00580	Effective Date of Reference Range
13	20	ST	C	[0..1]		00581	User Defined Access Checks
14	26	TS	RE	[0..1]		00582	Date/Time of the Observation
15	250	CE	RE	[0..1]		00583	Producer's ID
16	250	XCN	RE	[0..1]		00584	Responsible Observer
17	250	CE	C	[0..1]		00936	Observation Method
18	22	EI	O	[0..*]		01479	Equipment Instance Identifier
19	26	TS	RE	[0..1]		01480	Date/Time of the Analysis
20							Reserved by HL7 for future use
21							Reserved by HL7 for future use
22							Reserved by HL7 for future use

SEQ	LEN	DT	Usage	Card.	TBL#	ITEM#	Element name
23	567	XON	C	[0..1]		02283	Performing Organization Name
24	631	XAD	O	[0..1]		02284	Performing Organization Address
25	3002	XCN	O	[0..1]		02285	Performing Organization Director Name

2410 **OBX-1 Set ID - OBX (SI)**, required.

This field contains the sequence number of the OBX.

OBX-2 Value Type (ID), conditional.

2415 Condition predicate: This field shall be valued if OBX-5 (Observation Value) is populated. The Value Type field should be filled according to HL7 Version 2.5 standard (table 0125). For example, if the result is ">300" the Value Type "SN" (Structured Numeric) SHALL be used instead of the "ST" (String) value type that was used in previous versions of HL7. See the details and the examples in the HL7 V2.5 (7.4.2). For an observation that consists of a time measurement (e.g., bleeding time) the TM Value Type is preferred to NM but this is not made mandatory.

2420 **OBX-3 Observation Identifier (CE)**, required.

The usage of LOINC® test codes for the identification of tests is strongly recommended. Details of this free vocabulary can be found at <http://www.loinc.org>.

The first and third sub-fields “Identifier” and “Name of Coding System” are required in all transactions. The value of the “Name of Coding System” in the case of LOINC is “LN”.

2425 In transaction LAB-3 the second sub-field “Text” is mandatory, which allows the Order Result Tracker to manage the results without the help of Test Master File.

The last three sub-fields are optional in all transactions.

OBX-4 Observation Sub-ID (ST), conditional.

2430 HL7 Definition: This field is used to distinguish between multiple OBX segments with the same observation ID organized under one OBR.

Condition predicate:

This field is required in two situations:

- 2435 1. In a result message (ORU or OUL) when the OBR segment reports the results of a microbiology culture, then the Observation Sub-ID of each related OBX segment must be populated.
- 2440 2. In an order (OML) or result (ORU, OUL) message carrying observations, if under an OBR, there is more than one observation for the same Observation Identifier (OBX-3), then these multiple observations must value OBX-4 so that each OBX segment have a unique combination of OBX-3 (Observation Identifier) and OBX-4 (Observation Sub-ID) values.

In all other situations this field is optional.

Note: For usage of this field in microbiology see section C.11 “Microbiology Reporting Rules” and the microbiology example in Section 3.5)

OBX-5 Observation Value (varies), conditional.

2445 Condition predicate: This field is required unless the Observation Result Status field (OBX-11) is valued either with "D", or "I" or "X". The Observation Value field shall be valued according to the definition made in Chapter 7 of HL7 2.5 version.

OBX-6 Units (CE), conditional.

2450 This field should be populated when there is an effective observation value (OBX-5 not empty) and when the type of this observation value is numeric (OBX-2 = "NM" or "SN"). The content of this field shall be taken from the Unified Code for Units of Measure (UCUM).

OBX-7 References Range (ST), required if available.

2455 This field should be valued as described in HL7 V2.5 for all observations for which it is relevant. The References range that figures in this field is supposed to be related to age and sex of the patient or to other parameters such as number of weeks of pregnancy when applicable, which makes the OBX-10 field (nature of abnormal test) unnecessary.

OBX-8 Abnormal Flags (IS), required if available.

2460 This field is required when applicable. This field is repeatable in the IHE Laboratory Framework as in the standard. Among the possible values listed for this field in HL7 table 0078, the actors of the Technical Framework should support the following values:

HL7 Table 0078

Value	Description	Comment
L	Below low normal	
H	Above high normal	
LL	Below lower panic limits	
HH	Above upper panic limits	
N	Normal (applies to non-numeric results)	
A	Abnormal (applies to non-numeric results)	
AA	Very abnormal (applies to non-numeric units, analogous to panic limits for numeric units)	
Null	No range defined, or normal ranges don't apply	
S	Susceptible. Indicates for microbiology susceptibilities only.	
R	Resistant. Indicates for microbiology susceptibilities only.	
I	Intermediate. Indicates for microbiology susceptibilities only.	
MS	Moderately susceptible. Indicates for microbiology susceptibilities only.	
VS	Very susceptible. Indicates for microbiology susceptibilities only.	

The S, R, I, MS and VS values shall be used to indicate the interpreted result of susceptibilities in microbiology, in case the value field (OBX-5) contains a numeric value that represents the

2465 MIC (Minimum Inhibitive Concentration). In case the order filler only reports the interpreted result for susceptibilities, the S, R, I, MS and VS value could be filled in the value field (OBX-5) with a Value Type (OBX-2) set to "ST".

Note: For reporting antimicrobial susceptibilities in microbiology see section 3.11 "Microbiology Reporting Rules" and the microbiology example in section 19.5)

OBX-11 Observation Result Status (ID), required.

2470 This field should be filled according to HL7 Table 0085 described in Chapter 7 of HL7. In this version of the Technical Version, the possible values for this field are a subset of this table:

HL7 Table 0085

Value	Description	Comment
O	Order detail description only (no result)	This can be used in LAB-3 to provide the Order Result Tracker with the list of individual tests that will be performed
I	Specimen in lab; results pending	This can be used in LAB-3 to provide the Order Result Tracker with the list of individual tests that are being performed
D	Deletes the OBX record	This status should be used when the sender of a results message (analyzer, AM, POCDM, Order Filler...) wants to cancel a false result transmitted in a former message, in the situation where the right result is still pending. The result should NEVER be shown to clinical users.
R	Results entered – not verified	In results messages sent by analyzer, AM, POCDM: result not technically validated. In transaction LAB-3: result not clinically validated.
P	Preliminary results	In results message sent by analyzer, AM, POCDM: preliminary result technically validated but can still change In transaction LAB-3: preliminary result clinically validated but can still change
F	Final results; Can only be changed with a corrected result.	Can only be changed with a corrected result. In LAB-1 and LAB-3, a final result is clinically validated. In results message sent by analyzer, AM, POCDM, a final result is technically validated.
C	Record coming over is a correction and thus replaces a final result	This status may be used only after an 'F' or a 'C' status.
X	Results cannot be obtained for this observation	Tests that have this status have to be shown to the user.

Note: For the conditions of use of these values, please read Section C.10 "Correlations of status between ORC, OBR and OBX".

2475 **OBX-12 Effective Date of Reference Range (TS), not supported.**

Since the Reference range given by the order filler is the one that applies to the Observation result taking into account other parameters such as patient age or sex; there is no need to manage the present field. The Order Result Tracker should store the observation result and its associated reference range. In case the Order Result Tracker offers the capability to compare results of the

2480 same observation over different requests, it should then associate each result with its associated reference range.

OBX-13 User Defined Access Checks (ST), conditional.

2485 Condition predicate: In transaction LAB-3, the Order Filler should value this field with a "P" when it wants to inform the Order Result Tracker of restricted access on some results to privileged users.

OBX-14 Date/Time of the Observation (TS), required if available.

2490 This field should be valued when the OBX-5 field (Value field) is also valued. In very exceptional case this information may be unknown by the Order Filler (case the test is transmitted in a reference lab and observation date and time is not returned together with the result), this field can be null and the Order Result Tracker should not generate an error.

In all cases, the observation date-time is the physiologically relevant date-time or the closest approximation to that date-time. For tests performed on specimens, which is the case in the Technical Framework, the relevant date-time is the specimen's collection date-time.

OBX-15 Producer's ID (CE), required if available.

2495 This field is required in case the observation was not produced by the sending organization.

OBX-16 Responsible Observer (XCN), required if available.

2500 This field is required when the observation result status (OBX-11) is valued with "D" or "R" or "P" or "F" or "C" or "X" and the Producer's ID field is not valued. It should contain the identity of the observer that causes the change of the observation result status. Only the first component (ID number) of this field is necessary, provided that it is possible to retrieve the full identity of responsible person in the Order Filler system with only this ID number.

OBX-17 Observation Method (CE), conditional.

2505 Condition predicate: This field is required when the value of the result may be dependent of the Observation Method and the Observation Identifier does not permit to identify the Method. With some Observation Identifiers such as LOINC® Codes, the identifier also identifies the Method, in which case this field does not need to be valued.

OBX-18 Equipment Instance Identifier (EI), optional.

2510 HL7 definition: This field identifies the Equipment Instance (e.g., Analyzer, Analyzer module, group of Analyzers,...) responsible for the production of the observation. This is the identifier from an institution's master list of equipment, where the institution is specified by the namespace ID or if it is blank, then by the "Producer's ID" (OBX-15).

This repeatable field carries the instrument context of a laboratory result. The repeating of this field allows for the hierarchical representation of the equipment (lowest level first), e.g., module of an instrument, instrument consisting of modules, cluster of multiple instruments, etc.

2515 **OBX-19 Date/Time of the Analysis (TS)**, required if available.

HL7 definition: This field is used to transfer the time stamp associated with generation of the analytical result by the instrument specified in Equipment Instance Identifier (see above).

This field should be valued when the OBX-5 field (Value field) is also valued. It represents the effective date-time the test was performed on the analyzer or on the manual workbench.

2520 **OBX-23 Performing Organization Name (XON)**, conditional.

This field has been added by release 2.5.1 of HL7. It specifies the laboratory that produced the test result described in this OBX segment. When this field is null, the receiving system assumes that the observations were produced by the sending organization.

2525 Condition predicate: This field shall be valued in transaction LAB-3 when the test result carried by this OBX is produced by an outside laboratory, subcontracting a part of the order. In that case, this field shall be populated with the name of the subcontractor laboratory.

OBX-24 Performing Organization Address (XAD), optional.

This field has been added by release 2.5.1 of HL7. It specifies the address of the laboratory that produced the test result described in this OBX segment.

2530 This field may be valued in transaction LAB-3 when the test result carried by this OBX is produced by an outside laboratory, subcontracting a part of the order. If populated the field carries the address of the subcontractor laboratory.

2535 The Technical Framework does not constrain the usage further than this. Some national extensions of this Technical Framework (for example the US extension to deal with a CLIA amendment) may enforce this field to be valued whenever OBX-23 is valued.

OBX-25 Performing Organization Director Name (XCN), optional.

This field has been added by release 2.5.1 of HL7. It specifies the director of the laboratory that produced the test result described in this OBX segment.

2540 This field may be valued in transaction LAB-3 when the test result carried by this OBX is produced by an outside laboratory, subcontracting a part of the order. If populated the field carries the director's name of the subcontractor laboratory.

The Technical Framework does not constrain the usage further than this. Some national extensions of this Technical Framework (for example the US extension to deal with a CLIA amendment) may enforce this field to be valued whenever OBX-23 is valued.

2545 **C.10 Correlations of Status between ORC, OBR, OBX**

C.10.1 Semantics of the Main Status Code Associations

2550 In HL7 version 2.5 a change in the status of an observation is identified by a combination of the Trigger Event field contained in segment MSH, the ORC-5 (Filler Order status) field, the OBR-25 (Order Result Status) field and the OBX.11 (Observation Result Status) field. OBX-11 contains the status of an individual test, OBR-25 the status of the entire order.

Table C.10.1-1: Summary of the 3 Relevant Reference Tables:

Order Table 0038 (ORC-5)	Request Table 0123 (OBR-25)	Result Table 0085 (OBX-11)	Description (combined from 3 tables)
	O	O	Order received; specimen not yet received. Order detail description only (OBX contains no result). This value should only be used in ORL event acknowledgment messages. It should not be used in OML messages.
SC	S		No results available; procedure scheduled, but not done. The specimen may not have arrived at the laboratory. No OBX is present
IP	I	I	In process; The specimen is available in the laboratory; results are pending; the procedure is incomplete
		D	Deletes the OBX record
A	R	R	(Some) results entered -- not yet verified
A	P	P	(Some) preliminary verified results: (technically validated in LAB-5, clinically validated in LAB-3). The final results are not yet obtained
CM	F	F	Final results; results stored and verified: (technically validated in LAB-5, clinically validated in LAB-3). Can only be changed with a corrected result.
(CM)	C	C	Record coming over is a correction and thus replaces a final result
CA	X	X	(OBX) Results cannot be obtained for this observation. (ORC/OBR) No results available; Order canceled.

Notes:

The status codes used in ORC-5 are less 'atomic' than those used in OBR-25/OBX-11. If there is no direct 'semantic match' the ORC-5 column lists the closest equivalent between braces.

2555

The table shown above contains a description of the semantics of the code values used by these fields. Please note that this table does not identify all possible relationships of the various status fields. The relationship between the various status fields are described below.

C.10.2 Status Transition Diagrams

C.10.2.1 ORC-5: Order Status

2560

The status fields of an order and the associated result express the status of the order and result as they are processed and finalized. The transition of the coded values used in the status fields is shown below:

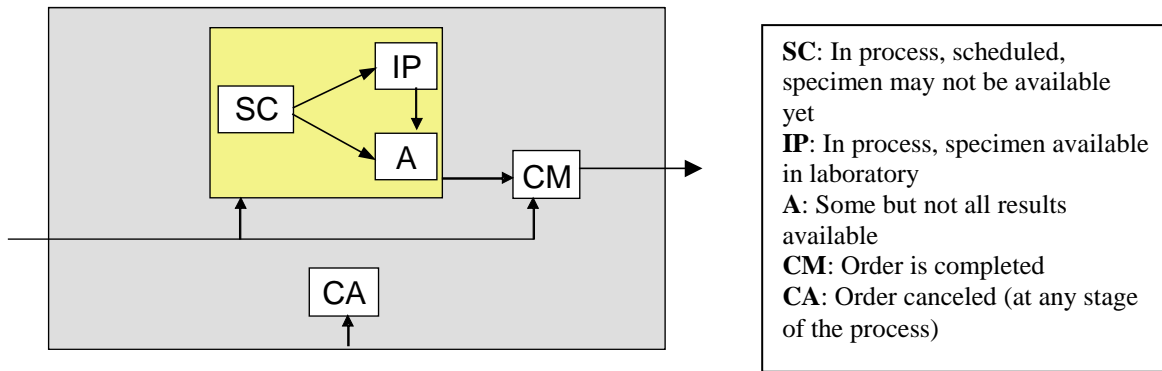
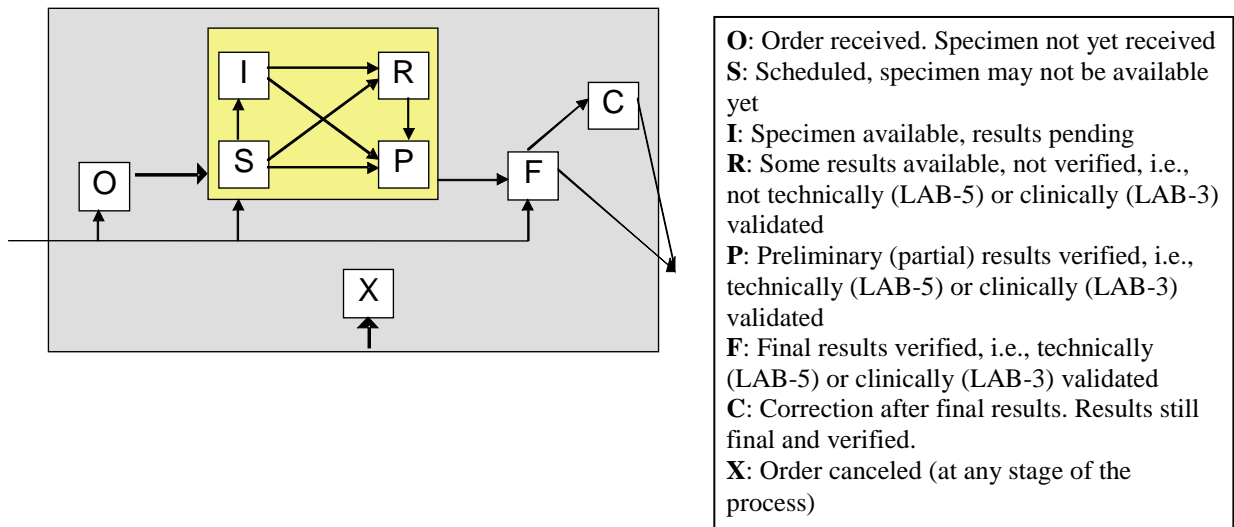

Figure C.10.2.1-1: The ORC-5 status transition diagram

2565 The status diagram in Figure C.10.2.1-1 above shows that, during normal processing, the initial status code in ORC-5 will be SC, IP, A or CM. If the status code equals SC, the next status code could be IP, A, CM or SC. If the status code equals IP, the next status code could be A, CM or IP. The special status codes CA (order was canceled) may occur at any stage of processing.

C.10.2.2 OBR-25: Order Result Status



2570

Figure C.10.2.2-1: The OBR-25 Status Transition Diagram

2575 The status diagram in Figure C.10.2.2-1 above shows that, during normal processing, the initial status code in OBR-25 will be O, F, or one of the four codes shown in the center block. If the status code equals S, the next status code could be either I, R, P, F or S. If the status code equals P, the next status code could be either F or P. If the status code equals F, the next status could be either F or C. The special status code X (order canceled) may occur at any stage of processing.

2580 **C.10.2.3 OBX-11: Observation Result Status**

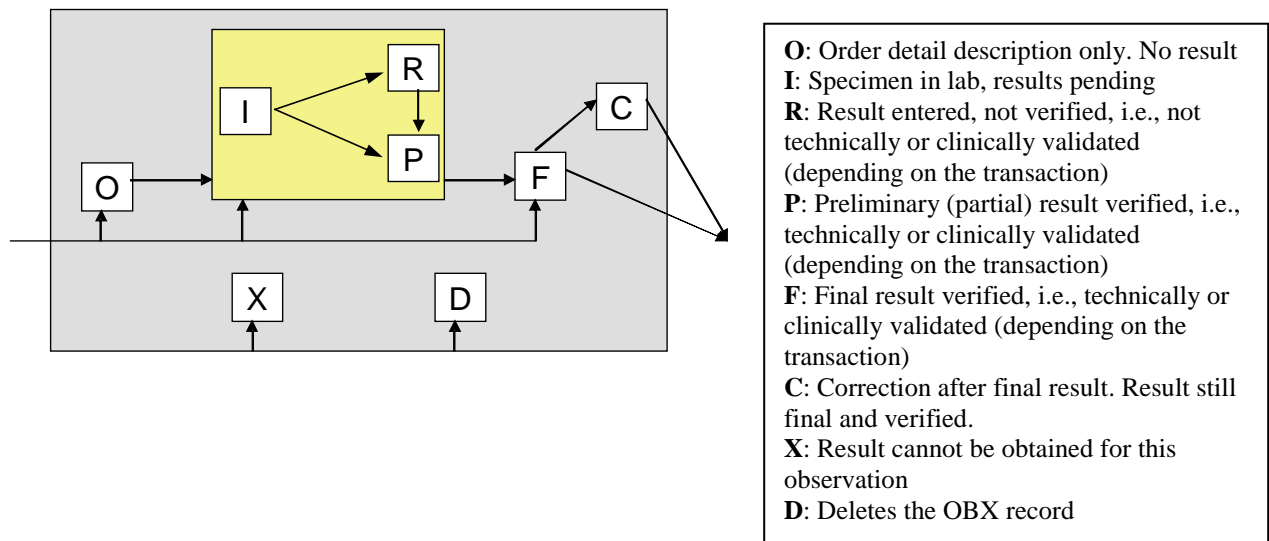

2585

Figure C.10.2.3-1: The OBX-11 Status Transition Diagram

The status diagram in Figure C.10.2.3-1 above shows that, during normal processing, the initial status code in OBX-11 will be O, F, or one of the three codes shown in the center block. If the status code equals I, the next status code could be either I, R, P or F. If the status code equals P, the next status code could be either F or P.

2590

The special status codes X (Result cannot be obtained for this observation) and D may occur at any stage of processing.

C.10.3 Relationship between the 3 Status Fields

The relationship between the 3 status fields is stated by the following rules:

2595

1. The status as contained in the OBR-25 field cannot be “higher/more finalized” than the “lowest” status of any of the related individual tests (as contained in OBX-11). For example: OBR-25 can only be ‘F’ (Final) when all related OBX-11 fields contain ‘F’.
2. The status of the order as defined by the Order Fulfiller cannot be “higher/more finalized” than the status of the related request (as contained in OBR-25). For example: ORC-5 can only be ‘CM’ (Complete) when the related OBR-25 field contains ‘F’ (Final) or ‘C’ (Corrected).
3. For the purposes of determining which status is “higher/more finalized”, any OBX-11 status code value equal to X or D, and any OBR-25 status code value equal to X should be compared as if the value was F.

2600

2605 **C.11 Microbiology Reporting Rules**

This section explains how messages carrying microbiology results shall be structured in transactions LAB-3, LAB-5 and LAB-23 of this Technical Framework.

Complete examples of microbiology result messages, compliant with these requirements are shown in Section 4.5 of Volume 2a.

2610 The requirements expressed in this section are aligned with Appendix A of the “*INTEROPERABLE LABORATORY RESULT REPORTING TO EHR (US REALM) RELEASE 1*” Implementation Guide and with Appendix A of the “*V 2.5.1 Implementation Guide: Orders & Observations; Ambulatory Care Lab Result (ELINCS), Release 1*”. Both implementation guides have been published by HL7 (www.hl7.org). These requirements on messages carrying
2615 microbiology results apply to the following exchanges:

1. from analyzer to LAS (transaction LAB-23)
2. from LAS to LIS (transaction LAB-5)
3. from LIS to CIS/EMR in intra-hospital workflow (transaction LAB-3)

C.11.1 Principle

2620 The effective reporting of culture results and antimicrobial sensitivities requires that data across different OBR segments and OBX segments be appropriately associated (for example, to associate the correct antimicrobial sensitivity with the correct cultured organism when multiple organisms have grown). HL7 v2.5.1 provides specific mechanisms to represent such associations, which must be used when reporting culture and sensitivity results.

2625 **C.11.2 Culture Results**

Culture results typically report the identity of cultured organisms and (sometimes) quantify the degree to which such organisms appear in the cultured specimen. Such results shall be reported as described below.

C.11.2.1 Definition

2630 A “culture” is any microbiological test in which infectious organisms are identified and characterized by allowing the organisms present in a specimen to reproduce in predetermined media in laboratory. The cultured organisms may be bacteria, viruses, or parasites. The results of any such test must be reported according to the specification below.

C.11.2.2 OBX-3 Observation Identifier

2635 For OBX segments in which a cultured organism is identified, an appropriate LOINC® code must be used, i.e., a code with the LOINC® component value of “MICROORGANISM IDENTIFIED”. There are approximately 175 such LOINC® codes in version 2.15 of the LOINC® terminology, varying with respect to the method of culture and the specimen type.

2640 The above example shows two organisms identified, reported with the LOINC® code 11475-1 in OBX-3.

For OBX segments in which the colony count of a cultured organism is reported, an appropriate LOINC® code must be used, i.e., a code with the component value of “COLONY COUNT”. There are approximately 10 such LOINC® codes in version 2.15 of the LOINC® terminology.

2645 The above example shows two colonies counted, reported with the LOINC® code 564-5 in OBX-3.

C.11.2.3 OBX-4 Observation Sub-ID

2650 Each OBX segment that reports a culture result must have the Observation Sub-ID field populated. OBX segments that contain information pertaining to the same identified microorganism must be “grouped” via the same value in the Observation Sub-ID field. For example, the first two OBX segments in the example above contain information pertaining to the Staphylococcus Aureus organism identified in the sputum sample (in this case, the identity of that organism and its colony count). These OBX segments, therefore, both have the Observation Sub-ID value of “1”. The second two OBX segments contain information pertaining to the Beta-hemolytic Streptococcus A organism, and both have the Observation Sub-ID value of “2”.

2655 Note 1: Even if only one OBX segment appears for each identified organism, the Observation Sub-ID field must be populated in these OBX segments, because the value of the Observation Sub-ID field is used to reference the appropriate OBX segment in subsequent reporting of antimicrobial sensitivities. Even in the case that only a single OBX segment is used to report a culture result, the Observation Sub-ID field must be populated, for the same reason. For example, if only one organism had been identified in the example above and no colony counts had been reported, the Observation Sub-ID field would still need to contain the value “1”.

2660 Note 2: Within any OBR segment, the OBX segments must be sequenced such that they are grouped by their Observation Sub-ID values. For example, in the culture result shown above, the OBX segments with the Observation Sub-ID value “1” all appear before the OBX segments with the Observation Sub-ID value “2”.

2665 Note 3: When the results of a specific culture are sent more than once (for example, as a preliminary result and later as a final result), the combination of OBX-3 (Observation Identifier) and OBX-4 (Observation Sub-ID) values for the identified organisms must be the same in each result message that is sent. This consistency allows the receiving system to correctly update the identified organisms as they are revised by the sending system. The example below shows the preliminary and the (subsequently sent) final values of a sputum culture, with the OBX-3 (Observation Identifier) and OBX-4 (Observation Sub-ID) values maintained correctly.

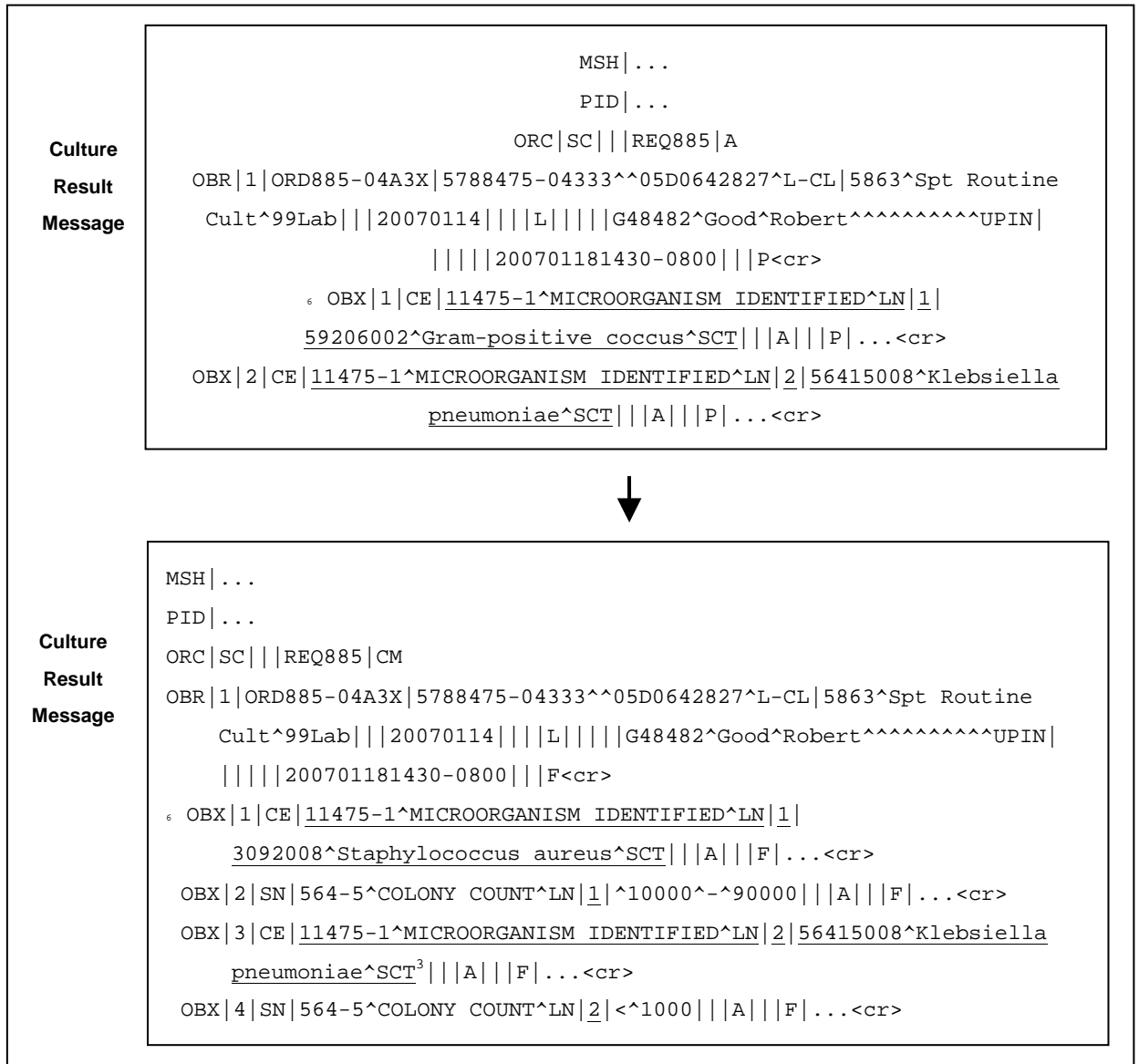

2670

Figure C.11.2.3-1: Example of Successive Culture Results Messages

C.11.2.4 OBX-5 Observation Value

2675

The value of each organism identified by a culture must be represented by a coded entity (CE data type). Use of a standard coding system, such as SNOMED CT®, will enable important reporting and decision-support capabilities for infectious diseases. When SNOMED codes are used, the SNOMED CT® concept ID should appear in the first component of OBX-5 and the coding system designator “SCT” should appear in the third component. The second component should be populated with an accurate text description of the organism identified, typically the

2680 preferred display term as assigned by the SNOMED CT® terminology. Regardless of the coding system used, the first three components of OBX-5 must be populated with the code, text description, and coding-system designator, respectively.

Note 1: Use of the SNOMED CT® terminology is most useful for encoding the Observation Value in the OBX that identifies an organism (e.g., the first and third OBX segments in the sample message above). The Observation Value for colony counts or other observations related to the culture may be represented in any reasonable way chosen by the laboratory.

2685 **C.11.3 Antimicrobial Sensitivities Results**

Antimicrobial sensitivity (or susceptibility) results report the sensitivity of cultured microorganisms to specific antibiotics, a standard part of medical microbiology and critical to the treatment of infectious diseases. The reporting of such tests in a uniformly structured and coded manner allows EHR systems to assist in the selection or assessment of antibiotic therapies, thereby promoting effective care and patient safety.

2690

Such tests shall be reported as described in this section.

C.11.3.1 Definition

2695 An antimicrobial sensitivity test is any test that assesses the susceptibility of a microorganism previously identified via culture to one or more specific antibiotic medications. The results of such a test may indicate, for example, that the microorganism is “susceptible,” “moderately susceptible,” or “resistant” to a specific antibiotic.

C.11.3.2 An Example

2700 The following example shows the final results of a sputum culture that identified *Staphylococcus aureus* and Beta hemolytic *Streptococcus A*, and the results of subsequent sensitivity testing on these organisms with respect to the antimicrobials Ampicillin and Amoxicillin/Clavulanate.

Note that the sensitivity tests were performed as “reflex tests,” i.e., they were initiated by the laboratory in response to the positive culture results.

This example is a message ORU^R01 of transaction LAB-3, assuming that transaction LAB-2 has been used in the meantime to obtain a Placer Order Number for the sensitivity test orders.

MSH|...
PID|...

**Culture
Results
with two
isolates
identified**

```

ORC|SC|||REQ885|CM
OBR|1|ORD885-04A3X1|5788475-04333^^05D0642827^L-CL2|5863^Spt Routine
  Cult^99Lab|||20070114|||L|||
  G48482^Good^Robert^^^^^^^UPIN|||200701181430-0800|||F<cr>
OBX|1|CE|11475-1^MICROORGANISM IDENTIFIED^LN|1|
  3092008^Staphylococcus aureus^SCT|||A|||F|...<cr>
OBX|2|SN|564-5^COLONY COUNT^LN|1|^10000^-^90000|||A|||F|...<cr>
OBX|3|CE|11475-1^MICROORGANISM IDENTIFIED^LN|2|
  412643004^Beta hemolytic Streptococcus A^SCT|||A|||F|...<cr>
OBX|4|SN|564-5^COLONY COUNT^LN|2|^<^1000|||A|||F|...<cr>
    
```

**Sensitivity
Result on
isolate 1
(reflex
test)**

```

ORC|SC|||REQ885|CM
OBR|2|ORD885-04A4Y1|5788475-04334^^05D0642827^L-CL2|6402^Bacterial Susc
  Panel Islt^99Lab|||20070114|||G|||
  G48482^Good^Robert^^^^^^^UPIN|||200701181430-0800|||F|
  11475-1&MICROORGANISM IDENTIFIED&LN^1^
  Staphylococcus aureus3|||
  ORD885-04A3X^5788475-04333&&05D0642827&L-CL4<cr>
OBX|1|NM|28-1^Ampicillin^LN6|1|32|ug/mL||R7|||F|...<cr>
OBX|2|NM|20-8^Amoxicillin+Clavulanate^LN5|1|2|ug/mL||S6|||F|...<cr>
    
```

**Sensitivity
Result on
isolate 2
(reflex
test)**

```

ORC|SC|||REQ885|CM
OBR|3|ORD885-04A5Z1|5788475-04335^^05D0642827^L-CL2|6402^Bacterial Susc
  Panel Islt^99Lab|||20070114|||G|||
  G48482^Good^Robert^^^^^^^UPIN|||200701181430-0800|||F|
  11475-1&MICROORGANISM IDENTIFIED&LN&783&CultOrg&99Lab^2^
  Beta hemolytic Streptococcus A3|||
  ORD885-04A3X^5788475-04333&&05D0642827&L-CL4<cr>
OBX|1|NM|28-1^Ampicillin^LN6|2|2|ug/mL||S7|||F|...<cr>
OBX|2|NM|20-8^Amoxicillin+Clavulanate^LN5|2|2|ug/mL||S6|||F|...<cr>
    
```

2705

2710

Superscript 1: OBR-2 Placer Order Number Superscript 2: OBR-3 Filler Order Number
 Superscript 3: OBR-26 Parent Result
 Superscript 4: OBR-29 Parent
 Superscript 5: OBR-50 Parent Universal Service Identifier Superscript 6: OBX-4 Observation ID

Superscript 7: OBX-8 Abnormal Flags

Figure C.11.3.2-1: Example of complete microbiology reporting, with sensitivity

2715 Note 1: Each Placer Order Number (OBR-2) and each Filler Order Number (OBR-3) in this message is unique, in conformance with this Technical Framework. In particular, the order numbers in the sensitivity tests differ from the order numbers of the culture. The laboratory requisition all these orders belong to, is identified by its Placer Group Number REQ885 in ORC-4.

C.11.3.3 OBR-26 Parent Result

2720 In the OBR segment of a sensitivity result, the value of the Parent Result field references the OBX segment for the identified organism that prompted the sensitivity testing. For example, the value in the Parent Result field of the first sensitivity result above is:

11475-1&MICROORGANISM IDENTIFIED&LN&783&CultOrg&99Lab^1^Staphylococcus aureus

2725 which references the Observation ID (OBX-3), Observation Sub-ID (OBX-4), and the text component of the Observation Value (OBX-5.2) of the first OBX segment in the culture result.

The table below shows the correspondence between the components and sub-components of OBR-26 Parent Result field in the sensitivity result and the fields and components of the corresponding OBX segment in the culture result:

2730 **Table C.11.3.3-1: Field OBR-26 - Parent Result (Sensitivity Result)**

Component/Sub-Component in OBR-26	Usage	Referenced Field/Component in Parent OBX Segment
OBR-26.1 (1 st component)	R	
OBR-26.1.1 (1 st sub-component)	R	OBX-3.1 Observation Identifier.Identifier
OBR-26.1.2 (2 nd sub-component)	RE	OBX-3.2 Observation Identifier.Text
OBR-26.1.3 (3 rd sub-component)	RE	OBX-3.3 Observation Identifier.Name of Coding System
OBR-26.1.4 (4 th sub-component)	RE	OBX-3.1 Observation Identifier.Alt Identifier
OBR-26.1.5 (5 th sub-component)	RE	OBX-3.2 Observation Identifier.Alt Text
OBR-26.1.6 (6 th sub-component)	RE	OBX-3.3 Observation Identifier.Name of Alt Coding System
OBR-26.2 (2 nd component)	R	OBX-4 Observation Sub-ID
OBR-26.3 (3 rd component)	R	OBX-5.2 Observation Value.Text

Note 1: Because organisms identified in culture results must be reported as coded entities, one can safely assume that OBX-5.2 of the parent result will be the text representation of a coded entity.

C.11.3.4 OBR-29 Parent

2735 OBR-29 references the values of the Placer Order Number (OBR-2) and the Filler Order Number (OBR-3) in the OBR segment of the culture result that spawned the sensitivity testing. OBR-29

must be populated when reporting the result of any reflex test, including an antimicrobial susceptibility.

In the example above, the value of OBR-29 for both sensitivity results is:

ORD885-04A3X^5788475-04333&&05D0642827&L-CL

2740 which reflects the values of OBR-2 and OBR-3 in the preceding culture result:

OBR-2: ORD885-04A3X OBR-3: 5788475-04333^^05D0642827^L-CL

Referencing the OBR-2 and OBR-3 values of the “parent” culture allows a receiving system to uniquely associate sensitivity results with the culture results that generated them.

2745 The table below shows the usage and semantic of the components of OBR-29 Parent field in the sensitivity result:

Table C.11.3.1-1: Field OBR-29 - Parent (EIP)

Component/Sub-Component	Usage
OBR-29.1 Placer assigned identifier (EI) → OBR-2 of culture OBR	R
OBR-29.2 Filler assigned identifier (EI) → OBR-3 of culture OBR	R

C.11.3.5 OBX-3 Observation Identifier

2750 For sensitivity results, the Observation Identifier must be encoded using the LOINC® terminology. Specifically, the value of the observation identifier must be one of the LOINC® codes designated to identify antimicrobials tested within susceptibility panels, i.e., codes with a PROPERTY attribute of “SUSC”. The LOINC® coding system includes approximately 1100 such codes, which cover all antimicrobials that are typically assessed in microbiology sensitivity testing.

Sample Values:

2755 1-8^ ACYCLOVIR^LN

12-5^AMIKACIN:MIC^LN

193-3^CLINAMYCIN:MIC^LN

395-4^ PENICILLIN V:MLC^LN

C.11.3.6 OBX-5 Observation Value

2760 For sensitivity results, the Observation Value field may be represented in whatever manner suits the laboratory and is consistent with conventional practice (in particular the MIC value). The uniform coding of the Abnormal Flags field (see below) is more important for the automated processing of sensitivity results.

C.11.3.7 OBX-8 Abnormal Flags

2765 For sensitivity results, the value of the Abnormal Flags field must be one of the following values from Table 0078:

Table C.11.3.7-1: Subset of HL7 Table 0078 for Antimicrobial Sensitivity

Value	Description
S	Susceptible. Indicates for microbiology susceptibilities only.
R	Resistant. Indicates for microbiology susceptibilities only.
I	Intermediate. Indicates for microbiology susceptibilities only.
SDD	Susceptible Dose Dependent

C.12 QAK – Query Acknowledgment Segment

2770 This segment is used in the response to query messages of these Transactions:

- Query for Label Delivery Instruction [LAB-62]
- Query for Work Order Step [LAB-22]

Table C.12-1: QAK Segment

SEQ	LEN	DT	Usage	Card.	TBL#	ITEM #	Element name
1	32	ST	C	[0..1]		00696	Query Tag
2	2	ID	R	[1..1]	0208	00208	Query Response Status
3	250	CE	O	[0..1]	0471	01375	Message Query Name
4	10	NM	O	[0..1]		01434	Hit Count
5	10	NM	O	[0..1]		01622	This payload
6	10	NM	O	[0..1]		01623	Hits remaining

QAK-1 Query Tag (ST), conditional.

2775 This field in the response message is echoing QPD-2 in the query message.

Condition predicate: QAK-1 shall be valued with the content of QPD-2 received in the query message.

QAK-2 Query Response Status (ID), required.

This mandatory field carries one of these values:

2780

HL7 Table 0208 - Query Response Status

Value	Description	Comment
-------	-------------	---------

Value	Description	Comment
OK	Data found, no errors (this is the default)	
NF	No data found, no errors	
AE	Application error	
AR	Application reject	

C.13 MFI – Master File Identification Segment

This segment is used by transaction [LAB-51].

Table C.13-1: MFI – Master File Identification

SEQ	LEN	DT	Usage	Card.	TBL#	ITEM#	Element name
1	250	CE	R	[1..1]	0175	00658	Master File Identifier
2	180	HD	R	[1..1]		00659	Master File Application Identifier
3	3	ID	R	[1..1]	0178	00660	File-Level Event Code
4	26	TS	O	[0..1]		00661	Entered Date/Time
5	26	TS	R	[1..1]		00662	Effective Date/Time
6	2	ID	R	[1..1]	0179	00663	Response Level Code

2785

MFI-1 Master File Identifier (CE), required.

It shall contain one of the values:

- OMA (Numerical Observation Master File)
- OMB (Categorical Observation Master File)
- OMC (Observation batteries master file)
- OMD (Calculated Observations Master File)

2790

MFI-2 Master File Application Identifier (HD), required.

Contains a code of up to 180 characters which uniquely identifies the application responsible for maintaining this file at a particular site.

2795 The value of this field shall be formatted by concatenating the values below using the “_” (underscore) character as a separator:

- the name of the application that owns the code set. This shall be equal to the value of the field MSH-3 Sending Application.
- the type of master file. This shall be equal to the value of the field MFI-1 Master File Identifier.

2800

- the language of the (textual descriptions of the) code set. This shall be equal to the value contained in the field MSH-19 Principal Language of the Message.
- (optional, if applicable) the version/revision of the code set. The character string used to identify a new version or revision should sort to be alphabetically “later” when compared to any previous versions or revisions.

2805

The resulting identifier will have the form “SENDINGAPP_MFTYPE_LANGUAGE” or “SENDINGAPP_MFTYPE_LANGUAGE_VERSION”. The receiver should not attempt to deconstruct this string into its constituent elements; it should use the identifying string in its entirety. With the exception of version/revision all elements are available elsewhere in the message.

2810

Examples include “Lab1_OMA_EN_1.2” or “X-PAS_OMB_FR”.

MFI-3 File-Level Event Code (ID), required.

It shall contain the value REP (replace current version of this master file with the version contained in this message).

2815

MFI-5 Effective Date/Time (TS), required.

Contains the date/time the Code Set Master expects that the event is to have been completed on the receiving system. The sending system should use the current date/time as a default. The Code Set Consumer shall process the event as soon as possible if the value of this field is in the past. If the value of this field is at some point in the future, then the Code Set Consumer shall process the event *before* that time.

2820

MFI-6 Response Level Code (ID), required.

It shall contain the value ER. The acceptance status of the individual master file entries is only to be reported in case of an error. Since the Technical Framework uses the HL7 original acknowledgment mode, all MFA segments must be returned via the application-level acknowledgment message.

2825

C.14 MFE – Master File Entry Segment

Table C.14-1: MFE – Master File Entry Segment

SEQ	LEN	DT	Usage	Card.	TBL#	ITEM#	Element name
1	3	ID	R	[1..1]	0180	00664	Record-Level Event Code
2	20	ST	R	[1..1]		00665	MFN Control ID
3	26	TS	O	[0..1]		00662	Effective Date/Time
4	200	Varies	R	[1..1]		00667	Primary Key Value – MFE
5	3	ID	R	[1..1]	0355	01319	Primary Key Value Type

MFE-1 Record-Level Event Code (ID), required.

2830 It shall contain the value MAD (add record to master file). Given that the file-level event code is REP, each MFE segment must have a record-level event code of MAD.

MFE-2 MFN Control ID (ST), required.

The response level code is ER. It contains an identifier that uniquely identifies the change to the record.

MFE-4 Primary Key Value – MFE, required.

2835 Uniquely identifies a record of the code set. The data type of this field is CE (coded element). One unique identifier shall be provided; the last 3 components of the CE data type shall not be valued.

MFE-5 Primary Key Value Type (ID), required.

Contains the value CE (coded element).

2840 **Appendix D – <Place Holder>**

Left blank intentionally.

Appendix E – Implementation Notes for POCT1-A DML

2845 The transactions LAB-30 and LAB-31 between the actors POCRG and POCDM rely on *Device Messaging Level* interface defined in Appendix B of the standard POCT1-A.. In this *DML* interface the POCRG Actor is called the “*Device*” and the POCDM Actor is called “*Observation Reviewer*”.

All messages of DML are encoded in XML (eXtended Markup Language). The syntax of each of these messages is defined by a DTD (Document Type Definition).

2850 The *Device* communicates with the *Observation Reviewer* through an *Access Point*, which can be part of a *Device* persistently connected to the network, or be a subsystem that consolidates data from one or more *Devices* onto an established communication link with the *Observation Reviewer* (POCDM).

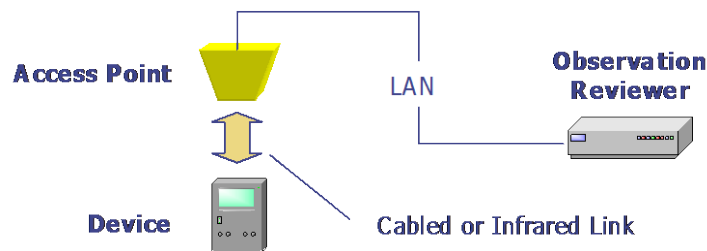

2855 **Figure E-1: Excerpt from POCT1-A**

The IHE LPOCT Profile does not describe the protocol between the *Device* and the *Access Point*, and recommends that manufacturers refer to and adopt the standard POCT1-A specification for this layer.

2860 The IHE LPOCT Profile describes the use of the DML, which is the top layer of the interface between the *Device* (POCRG Actor) and the *Observation Reviewer* (POCDM Actor). The lower layer protocols are not described in this IHE profile. IHE recommends the use of the MLLP transport protocol between the Device Access Point and the POCDM, as this protocol is used by all profiles of the Technical Framework.

E.1 IHE usages for DML

2865 The conventions of usage in the DML interface from POCT1-A are the same as those defined for HL7 messages in Section 2.2.1 of this volume (R, RE, O, C, X).

E.2 Conversations and Topics

Appendix B of POCT1-A defines two terms:

2870 **Conversation:** A prescribed flow of messages between the Device and Observation Reviewer, having both an initialization and a termination phase. A Conversation is made up of a series of ‘Topics.’

Topic: The flow of messages to exchange a complete set of data within a Conversation (e.g., Observations, Device Events). A Topic is composed of a series of ‘Messages.’

2875 The IHE LPOCT Profile describes only the Topic **Observations** which is used by Transactions LAB-30 and LAB-31. It is assumed that the systems implementing a POCRG Actor or a POCDM Actor support the other Topics listed below, according to the standard POCT1-A.

POCT1-A “basic profile” for transaction LAB-31

2880 To support Transaction LAB-31 of LPOCT Integration Profile, a **Device** (POCRG Actor) and an **Observation Reviewer** (POCDM Actor) must support at least the “**Basic Profile**”, as defined in Appendix B section 4.1 of POCT1-A.. This “**Basic Profile**” specifies a minimum set of “**Topics**” that Devices and Observation Reviewers must support. These Topics are:

- Hello
- Device Status
- 2885 • Observations
- Terminate

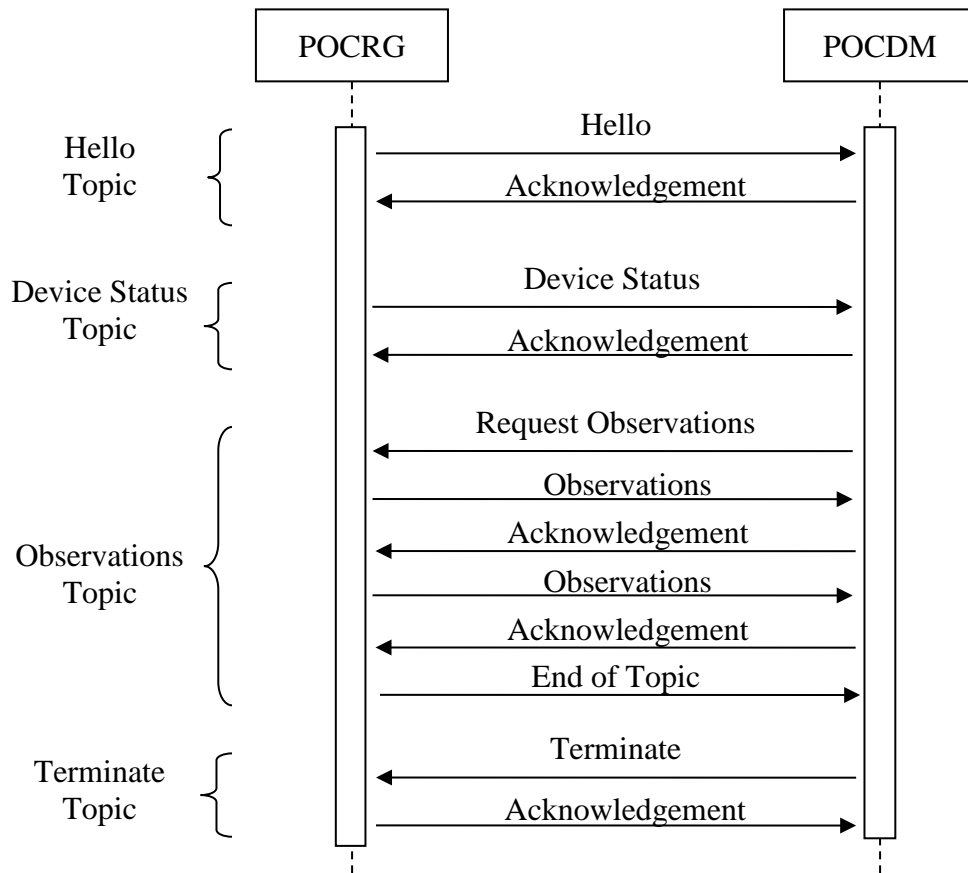

Figure E.2-1: Error-Free Basic Profile Flow, POCT1-A – Appendix B

2890 The “Terminate” topic can also be performed in reverse, with the POCRG sending a Terminate message and the POCDM acknowledging it. This termination can occur at any time.

Continuous Mode to support Transactions LAB-30 and LAB-31

2895 To support the “Patient Identity Checking” Option of this Profile (i.e., the transaction LAB-30 between POCRG and POCDM) the *Device* (POCRG) and the *Observation Reviewer* (POCDM) must support the “*Continuous Mode*”, as defined in Appendix B of POCT1-A.. This *Continuous Mode* requires that Devices and Observation Reviewers support a more complete set of *Topics*:

- Hello
- Device Status
- 2900 • Directives (with at least START_CONTINUOUS Directive)
- Observations

- Keep Alive
- Termination

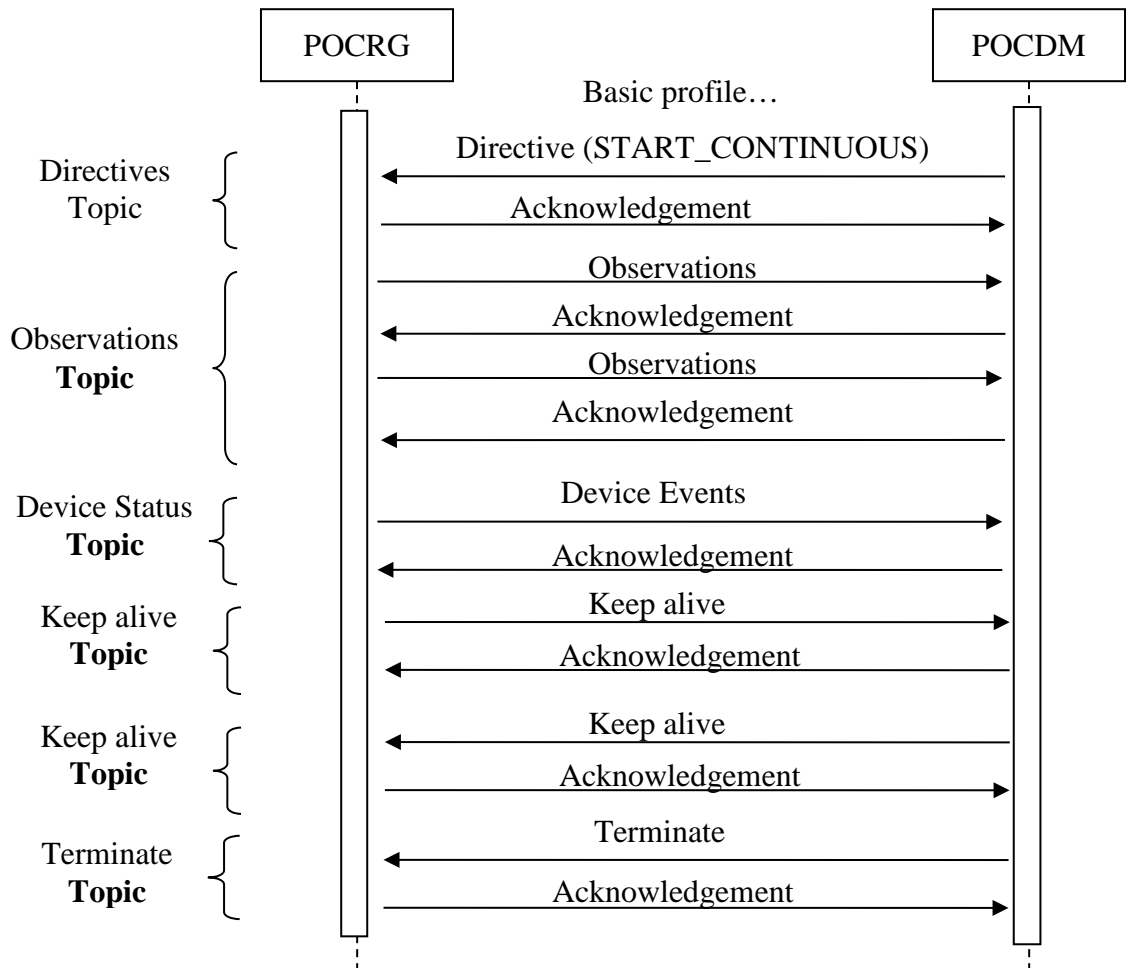

2905

Figure E.2-2: Continuous Mode

E.3 Characteristics of DML Messages

Notation

2910 DML messages are encoded in XML. As any XML document, a DML message is a hierarchic tree. The POCT1-A standard uses the following representation for this hierarchic structure:

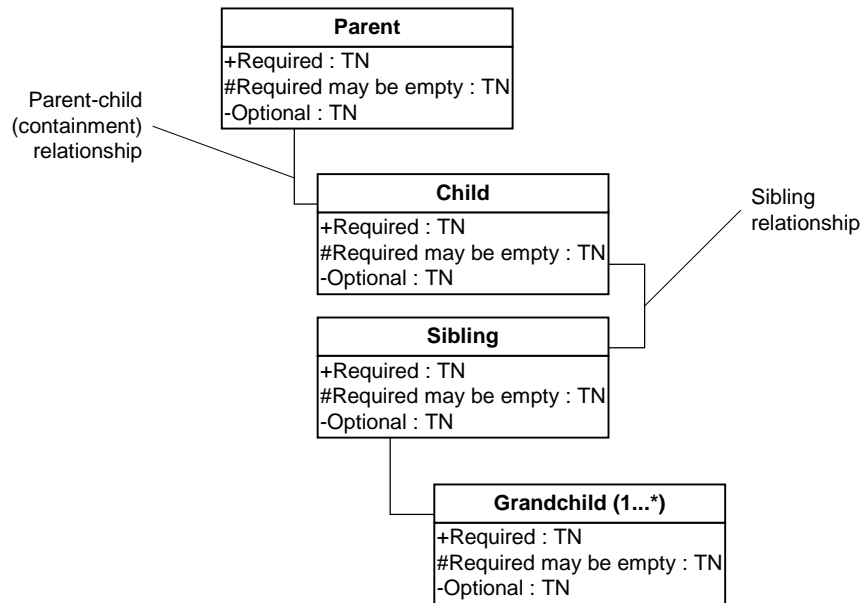

Figure E.3-1: Message Model Example, excerpt from POCT1-A – Appendix B

Each element is represented as an object. Object cardinality is noted as part of the object name:

- 2915
- (0...1) – zero or one instance
 - (0...*) – zero or more instances
 - (1...*) – one or more instances
 - The absence of a cardinality notation indicates one, and only one, instance

The components of the object are sub-elements of the XML element.

- 2920
- sub-elements preceded by '+' are Required
 - sub-elements preceded by a '-' are Optional
 - sub-elements preceded by '#' are Required if available (may be empty if there is no relevant data (which corresponds to the "RE" usage code))

Use of the Header Object in DML Messages

2925 Every message of the DML starts with a mandatory Header object encoded with the XML **<HDR>** element. This IHE profile defines the following usage for this object:

Attribute	Data Type	IHE Usage	IHE Cardinalities	Description
message_type	CV	X	[0..0]	A code made up of the message name and trigger value. Examples: "OBS.R01", "ACK.R01". This field is redundant with the root element of the message. It is not supported by IHE.
control_id	ST	R	[1..1]	A string guaranteed to uniquely identify this message instance throughout the conversation
version_id	ST	R	[1..1]	Set to "POCT1" for all messages that adhere to this standard
creation_dttm	TS	R	[1..1]	The sender's time when the message was sent.
encoding_chars	ST	X	[0..0]	Not used by IHE

Example of the beginning of a message of the Hello Topic:

2930

```
<HEL.R01>
  <HDR>
    <HDR.control_id V="10001"/>
    <HDR.version_id V="POCT1"/>
    <HDR.creation_dttm V="2001-11-01T16:30:00-08:00"/>
  </HDR>
  ...
```

2935

Hello Topic in DML

The Hello Topic contains two messages: The Hello message sent by the *Device* (POCRG) and the acknowledgement message sent by the *Observation Reviewer* (POCDM).

2940

A Device sends the Hello message only once as the first message in a Conversation. This message identifies the *Device*, its capabilities, its status, and the *Access Point* with its unique network address and port number.

2945

- The root element of this message is <HEL.R01>
- The header element of this message, is mike in any message <HDR>
- The element representing the Device (POCRG) is <DEV>
- The element representing the Device capabilities is <DCP>
- The element representing the Device static capabilities is <DSP>
- The element representing the Access Point is <AP>

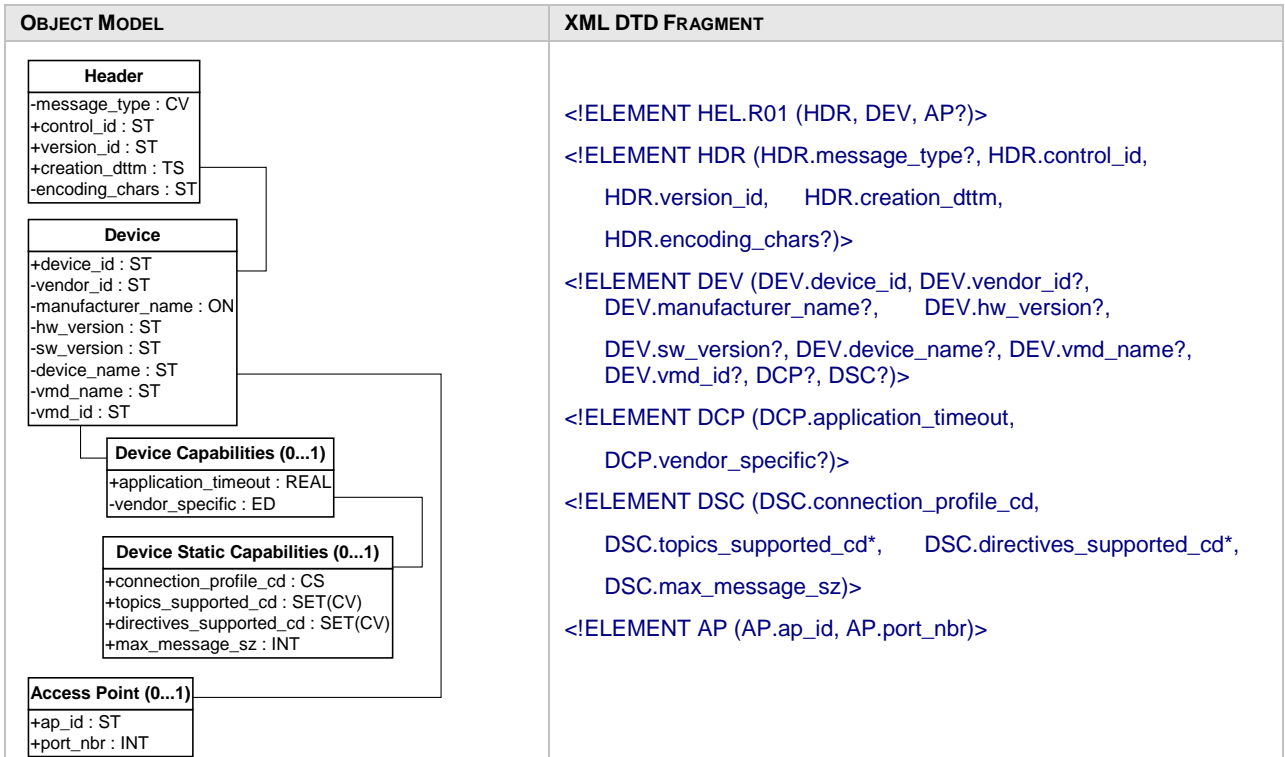

Figure E.3-2: Hello Message Model, excerpt from POCT1-A – Appendix B

2950 Example of Hello message taken from POCT1-A – appendix B:

```

2950 <HEL.R01>
2955   <HDR>
2960     <HDR.control_id V="10001"/>
2965     <HDR.version_id V="POCT1"/>
2970     <HDR.creation_dttm V="2001-11-01T16:30:00-08:00"/>
2975   </HDR>
2980   <DEV>
2985     <DEV.device_id V="0A-00-19-00-00-00-23-84"/>
2990     <DEV.vendor_id V="BCHMX"/>
2995     <DEV.model_id V="8000A"/>
3000     <DEV.serial_id V="42367C"/>
3005     <DEV.manufacturer_name V="Biochemtronix"/>
3010     <DEV.hw_version V="8000A-C"/>
3015     <DEV.sw_version V="2001-10-04"/>
3020     <DEV.device_name V="ICU-4 Glucose"/>
3025     <DCP>
3030       <DCP.application_timeout V="60"/>
3035     </DCP>
3040     <DSC>
3045       <DSC.connection_profile_cd V="SA"/>
3050       <DSC.topics_supported_cd V="DTV"/>
3055       <DSC.topics_supported_cd V="OP_LST"/>
3060       <DSC.directives_supported_cd V="SET_TIME"/>
3065       <DSC.directives_supported_cd V="LOCK"/>
3070       <DSC.directives_supported_cd V="UNLOCK"/>

```

2980

```

        <DSC.max_message_sz V="800"/>
      </DSC>
    </DEV>
  <AP>
    <AP.ap_id V="00-10-9D-FF-FF-23-45-67"/>
    <AP.port_nbr V="0"/>
  </AP>
</HEL.R01>

```

E.4 Main Data Types in DML for Transactions LAB-30 and LAB-31

2985

PN – Person name

The PN data type is used to communicate the elements of a person’s name. This data type may carry:

- One single attribute “V” that contains a formatted for display version of the name.
- Any of the child elements described below:

2990

Element	Use
GIV	The given name component
MID	The middle name component
FAM	The family name component
PFX	A prefix component (e.g., “Dr.”)
SFX	A suffix component (e.g., “Ph.D”)
DEL	A delimiter character used to separate components

Example: The following XML fragment illustrates how the **OPR.name field** can be used to encode the operator “Dr. John Ebert.”

2995

```

<OPR.name V="Dr. John Ebert">
  <FAM V="Ebert"/>
  <GIV V="John"/>
  <PFX V="Dr."/>
  <SFX V="MD"/>
</OPR.name>

```

3000

PQ – Physical Quantity

The PQ data type is used to communicate a measured value, with the units of measure. The attributes this data type may use are described in the following table. Either the ‘V’ and the ‘U’ attributes or the ‘NULL’ attribute must be specified.

3005

Table 72: PQ Data Type Attributes

Field	Required	Use
V	No	Contains the string representation of the value (1)

Field	Required	Use
U	No	Indicates the units of measure for the value (2)
NULL	No	Indicates one of the values from Table 70

Note 1: Trailing zeros may be used in the 'V' attribute to indicate precision.

Note 2: The HL7 "ISO+" units code set, defined in a section of the HL7 v2.5 specification, comprises the default values for the PQ units attribute. This specification defines an abbreviation for a single case unit (ISO 2955-83) plus extensions, which do not collide with ISO abbreviations.

3010 Example of a pCO₂ value of 71.1 mmHg: `<OBS.value V="71.1" U="mmHg"/>`

Example of a patient's height value of 1.85 m: `<PT.height V="1.85" U="m"/>`

TS – Point in time

This data type is used to communicate a point in time. This data type may use one and only one of these two alternative attributes:

3015 'V': String representation of a point in time: YYYY-MM-DDTHH:MM:SS.SSxOH:OM

Where:

3020 YYYY = four-digit year;
MM = two-digit month of the year;
DD = two-digit day of the month;
HH = 24-hour representation of the hour;
MM = minute;
SS.SS = second (optional decimal digits may follow the '.' separator);
3025 x = '+' if time is GMT *plus* offset; '-' if time is GMT *minus* offset;
OH = hours offset from GMT; and
OM = minutes offset from GMT.

'NULL': One of the values from Table 70:

3030 Example: The following XML fragment illustrates how a device could communicate that an observation was made on June 1, 2005 at 5:09:10 PM, in the time zone of Tokyo that is nine hours prior to GMT: `<SVC.observation_dttm V="2005-06-01T17:09:10+09:00"/>`

Table 70: Null Code Values

Value	Use
NI	No Information
NA	Not Applicable
UNK	Unknown
NASK	Not Asked
ASKU	Asked But Unknown
NAV	Not Available
OTH	Other

Value	Use
PINF	Positive Infinity
NINF	Negative Infinity

Glossary

3035 The IHE Glossary can be found as an appendix to the *IHE Technical Frameworks General Introduction* published on [this page](#).