



5

IHE Radiology Technical Framework Supplement

10

Chest X-Ray CAD Display (CXCAD)

15

Date: June 17, 2010
Author: Michael Planchart
Email: radiology@ihe.net

20

Foreword

25 This is a supplement to the IHE Radiology Technical Framework 9.0 Each supplement undergoes a process of public comment and trial implementation before being incorporated into the volumes of the Technical Frameworks.

This supplement is submitted for Trial Implementation as of June 17, 2010 and will be available for testing at subsequent IHE Connectathons. The supplement may be amended based on the results of testing. Following successful testing it will be incorporated into the Radiology Technical Framework. Comments are invited and may be submitted on the IHE forums at 30 <http://forums.rsna.org> or by email to radiology@ihe.net.

This supplement describes changes to the existing technical framework documents and where indicated amends text by addition (**bold underline**) or removal (~~**bold strikethrough**~~), as well as addition of large new sections introduced by editor's instructions to "add new text" or similar, which for readability are not bolded or underlined.

35 "Boxed" instructions like the sample below indicate to the Volume Editor how to integrate the relevant section(s) into the relevant Technical Framework volume:

<i>Replace Section X.X by the following:</i>
--

40 General information about IHE can be found at: www.ihe.net

Information about the IHE Radiology can be found at: <http://www.ihe.net/Domains/index.cfm>

Information about the structure of IHE Technical Frameworks and Supplements can be found at: <http://www.ihe.net/About/process.cfm> and <http://www.ihe.net/profiles/index.cfm>

45 The current version of the IHE Technical Framework can be found at: http://www.ihe.net/Technical_Framework/index.cfm

CONTENTS

Introduction..... 3
Profile Abstract 3
50 Open Issues and Questions 3
Closed Issues 3
Volume 1 – Integration Profiles..... 6
Glossary 6
1.7 History of Annual Changes 6
55 2.1 Dependencies among Integration Profiles 7
2.2.27 Chest X-Ray CAD Display Integration Profile 7
27 Chest X-Ray CAD Display Integration Profile 7
27.1 Actors/ Transactions..... 7
27.2 Chest X-Ray CAD Display Integration Profile Options 9
60 27.3 Chest X-Ray CAD Display Process Flow..... 9
27.4 Chest X-Ray CAD Display Security Considerations 11
<Appendix A> Actor Summary Definitions 11
<Appendix B> Transaction Summary Definitions 11
Volume 2 – Transactions 12
65 **Volume 3 - Transactions..... 15**
4.43.3 Referenced Standards 15

70

Introduction

Profile Abstract

75 The Chest X-Ray CAD Display Profile specifies how DICOM Chest CAD evidence objects are applied for display. It describes how Image Displays make use of the content in the Chest CAD SR SOP instance to render the CAD marks on projection radiographs of the chest encoded as CR, DX or Secondary Capture images.

Open Issues and Questions

None.

Closed Issues

- 80 1. *Workflow and dependencies on workflow profiles (e.g. SWF, RWF, PPWF) are out of the scope of this profile, and neither the common “push” model in the installed base or the formally defined PPW profile in IHE are required for this profile.*
2. *Re-Processing workflow is not defined, whether it be performed on the Acquisition Modality, Image Display or other device.*
- 85 3. *No specific requirements for Portable Data for Imaging (PDI) are specified, meaning that whilst Chest X-Ray objects may be stored on media, the choice of which types of objects (“For Processing”, “For Presentation” Images, Chest CAD SR, other SR reports, Presentation States or Key Image Notes), is at the discretion of the implementor.*
4. *An Image Display is not required to be a Print Composer, and here is no need to specify Print Composer behavior in this profile since printing CAD marks is not a viable use case.*
- 90 5. *No attempt is made to “standardize” particular choices of hanging protocols.*
6. *Display functions of anything other than displaying the CAD marks which were obtained from a Chest CAD SR are out of the scope of this profile.*
- 95 7. *Consideration of common or special features that the Image Display should have (e.g. Window/Level, Zoom, Pan) are out of the scope of this profile.*
8. *CT is out of the scope of this profile since it has been determined that it requires Image Display functionality that is beyond what is required for display of projection radiographs.*
- 100 9. *Chest X-Ray specific reporting workflow is not defined, nor are the objects in which a Chest X-Ray report might be encoded (such as DICOM SR objects with the Chest X-Ray Reporting template).*
-

- 105 10. *Image Manager/Archive Actors shall be able to not only receive but also respond to queries for and return Chest CAD SR objects from Evidence Creators (CAD systems), so that the Image Display can make use of them directly (rather than have them burned in to images or converted into presentation states).*
- 110 11. *Display of CAD Marks is defined in the Retrieve Images transaction rather than the Retrieve Evidence Documents transaction (from which there is a reference), in order to have all rendering requirements for the Image Display located in the same place in the document for clarity.*
12. *If more than one set of CAD objects are available for the same image, then all need to be made available for display at the user's discretion. This creates a need to also display the date and time that CAD was performed.*
- 115 13. *There are no specific requirements on the Acquisition Modality with respect to additional constraints on CR, DX or Secondary Capture images to which CAD might be applied.*
14. *Unlike Mammo CAD, there is not typically a dependence of Chest CAD Evidence Creators on "For Processing" images.*
- 120 15. *Further markup on the images (after display of CAD and interpretation by the reader) can be saved via CPI in Presentation States, but there is then no means of correlating that markup with the CAD mark locations or instance. It has been determined that there is no need for an additional mechanism to capture positive or negative responses made by the user related to the CAD marks that were displayed. This capturing will be done using the existing approaches used by Image Displays. Feedback obtained from radiologists' does not indicate that this is an existing user requirement.*
- 125 16. *No mechanism for getting the images to the Evidence Creator will be explicitly specified. This was excluded from the Mammography Image Profile (MAMMO) and we will adopt the same decision with this profile. There is no need for IHE defining how to Query/Retrieve DICOM images in a content profile.*
- 130 17. *There is no need for the content profile to address constraints on the content of Chest CAD SR objects (e.g., "dumb down" the potentially complex DICOM template). There is not sufficient data of specific use cases implemented in order to determine best approaches. As the DICOM standard indicates in the section A.35.6.1 "Chest CAD SR Information Object Description" the content of the SR shall include textual and a variety of coded information, numeric measurement values, references to the SOP Instances, and spatial regions of interest within such SOP Instances.*
- 135 18. *There is no need for defining a mechanism for signalling that CAD evidence documents are not intended to be persistently stored be addressed in this profile, this is a site specific configuration and it is not an interoperability or integration issue. The Mammography Image Profile dealt with this problem as well and it was decided that it would not be addressed.*
- 140

19. *The Spatial Locations Preserved is not required since “For Processing” images are not supported in this profile.*
20. *The Image Display shall be capable of displaying more than one image (e.g. current and priors). This is also addressed in the current text.*
- 145 21. *There are scenarios where more than one SR may be produced per CAD session, where a session is the processing of one image. When there are multiple SRs per processed image the Image Display shall allow the user to select which SR should be displayed over the image.*
- 150 22. *There is no mechanism defined to specify the appearance of the rendered marks (e.g., shape, size, color or the line thickness). The way of displaying the rendered marks is part of the filing. This is consistent with the Mammography Image Profile.*
23. *CAD findings specific information (e.g., operating point, CAD algorithm, version) is not considered information that is useful to the user and there is no requirement for the Image Display to present this information.*

155

Volume 1 – Integration Profiles

Glossary

Add the following terms to the Glossary:

...

160 1.7 History of Annual Changes

Add the following bullet to the end of the bullet list in section 1.7

- Added the Chest X-Ray CAD Display Profile.

- 165 • Modified the following transactions:

[RAD-16] Retrieve Images Transaction was modified by adding the following sections:

- 4.16.4.1.3.3 Chest X-Ray CAD Display Profile
- 4.16.4.2.2.1.2 Display of Chest X-Ray Images
- 170 4.16.4.2.2.1.2.1 Chest X-Ray CAD Marks

[RAD-43] Evidence Document Stored Transaction was modified by adding the following section:

- 4.43.4.1.3 Expected Actions
- 175 4.43.4.1.3.2 Chest X-Ray CAD Display Profile

[RAD-44] Query Evidence Documents Transaction was modified by adding the following section:

- 180 4.44.4.1.3.2 Chest X-Ray CAD Display Profile

[RAD-45] Retrieve Evidence Documents Transaction was modified by adding the following section:

- 4.45.4.2.3.2 Chest X-Ray CAD Display Profile

185 **2.1 Dependencies among Integration Profiles**

No new dependencies.

Add the following section to section 2.2

2.2.27 Chest X-Ray CAD Display Integration Profile

190 **The Chest X-Ray CAD Display Profile specifies how DICOM Chest CAD evidence objects are applied for display. It describes how Image Displays make use of the content in the Chest CAD SR SOP instance to render the CAD marks on projection radiographs of the chest encoded as CR, DX or Secondary Capture images.**

Add Section 27

195 **27 Chest X-Ray CAD Display Integration Profile**

The Chest X-Ray CAD Display Profile specifies how DICOM Chest CAD evidence objects are applied for display. It describes how Image Displays make use of the content in the Chest CAD SR SOP instance to render the CAD marks on projection radiographs of the chest encoded as CR, DX or Secondary Capture images.

200 **27.1 Actors/ Transactions**

Figure 27.1-1 shows the actors directly involved in the Chest X-Ray CAD Display Integration Profile and the relevant transactions between them.

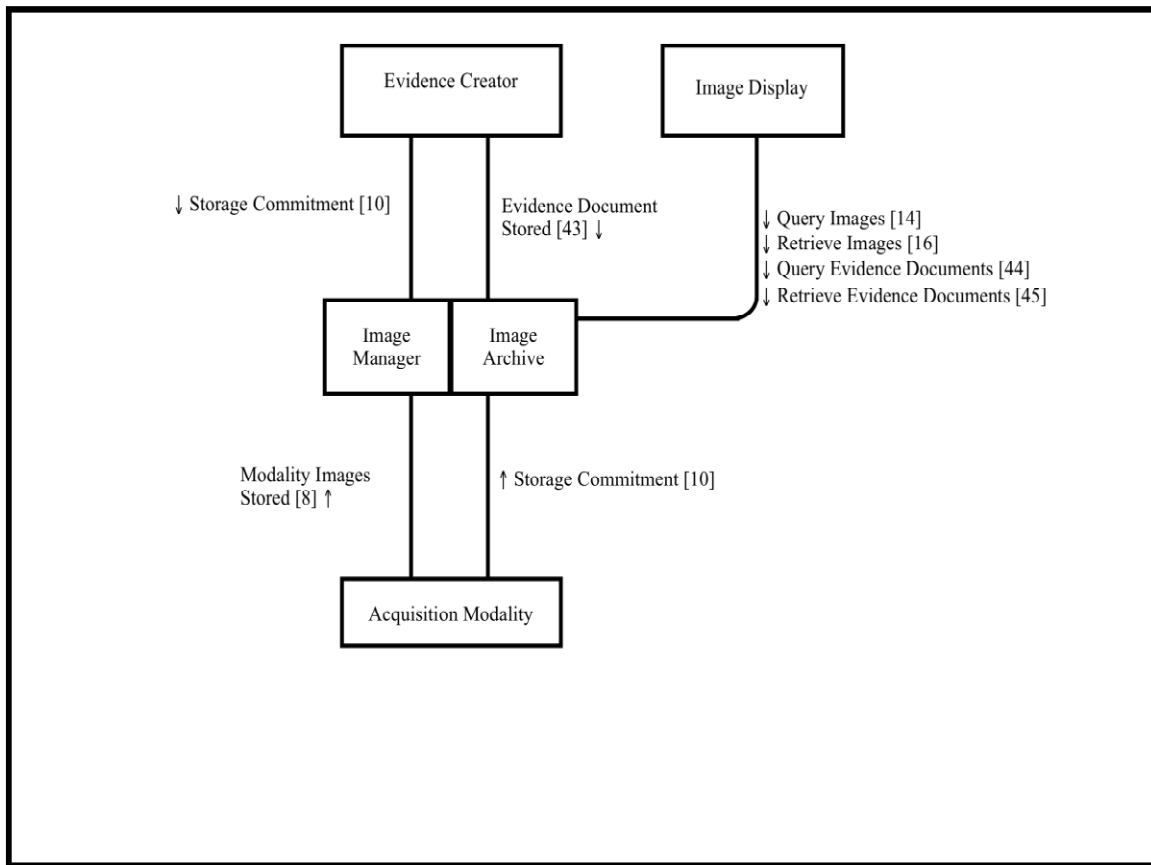

205

Figure 27.1-1. Chest X-Ray CAD Display Actor Diagram

Table 27.1-1 lists the transactions for each actor directly involved in the Chest X-Ray CAD Display Profile. In order to claim support of this Integration Profile, an implementation must perform the required transactions (labeled “R”). Transactions labeled “O” are optional. A complete list of options defined by this Integration Profile and that implementations may choose to support is listed in Volume I, Section 27.2.

210

Table 27.1-1. Chest X-Ray CAD Display Integration Profile - Actors and Transactions

Actors	Transactions	Optionality	Section in Vol. 2/3
<u>Acquisition Modality</u>	<u>Modality Images Stored [RAD-8]</u>	R	4.8
	<u>Storage Commitment [RAD-10]</u>	R	4.10
<u>Evidence Creator</u>	<u>Evidence Document Stored [RAD-43]</u>	R	4.43
	<u>Storage Commitment [RAD-10]</u>	R	4.10
<u>Image Manager/Archive</u>	<u>Modality Images Stored [RAD-8]</u>	R	4.8
	<u>Evidence Document Stored [RAD-43]</u>	R	4.43

	<u>Storage Commitment [RAD-10]</u>	<u>R</u>	<u>4.10</u>
	<u>Query Images [RAD-14]</u>	<u>R</u>	<u>4.14</u>
	<u>Retrieve Images [RAD-16]</u>	<u>R</u>	<u>4.16</u>
	<u>Query Evidence Documents [RAD-44]</u>	<u>R</u>	<u>4.44</u>
	<u>Retrieve Evidence Documents [RAD-45]</u>	<u>R</u>	<u>4.45</u>
<u>Image Display</u>	<u>Query Images [RAD-14]</u>	<u>R</u>	<u>4.14</u>
	<u>Retrieve Images [RAD-16]</u>	<u>R</u>	<u>4.16</u>
	<u>Query Evidence Documents [RAD-44]</u>	<u>R</u>	<u>4.44</u>
	<u>Retrieve Evidence Documents [RAD-45]</u>	<u>R</u>	<u>4.45</u>

27.2 Chest X-Ray CAD Display Integration Profile Options

215 **Options that may be selected for this Integration Profile are listed in the table X.2-1 along with the Actors to which they apply.**

Table 27.2-1 Chest X-Ray CAD Display - Actors and Options

Actor	Options	Vol & Section
<u>Acquisition Modality</u>	<i>No options defined</i>	--
<u>Image Archive/Manager</u>	<i>No options defined</i>	--
<u>Image Display</u>	<i>No options defined</i>	--
<u>Evidence Creator</u>	<i>No options defined</i>	--

27.3 Chest X-Ray CAD Display Process Flow

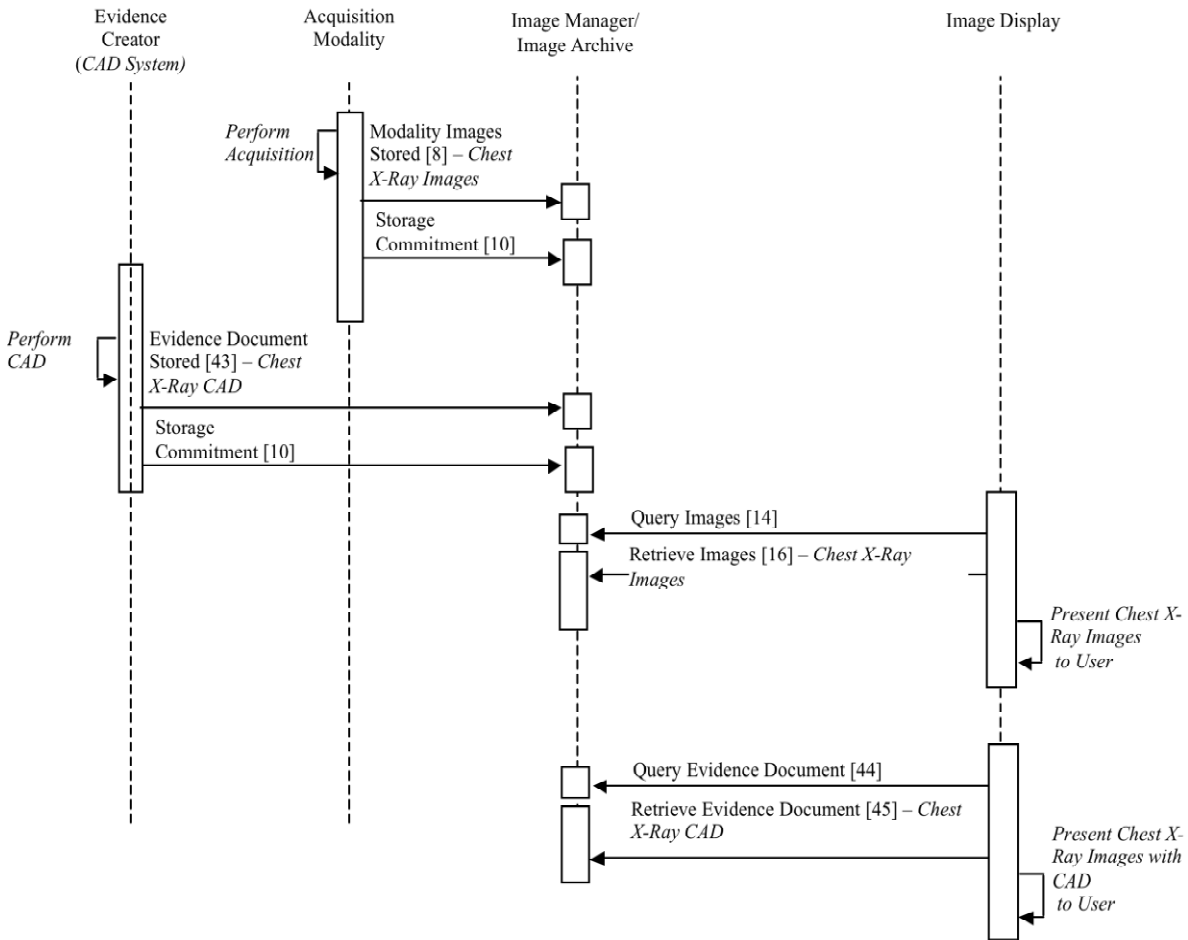

Figure 27.3-1. Basic Process Flow in Chest X-Ray CAD Display Profile

This section describes the process flow related to the use of the Chest CAD SR SOP within the context of this profile.

It is out of the scope of this profile to address the transactions between the Acquisition Modality actor and the Evidence Creator actor (i.e., the workflow by which the images are made available to the Evidence Creator), hence it is not illustrated in Figure 27.3-1.

An Image Archive that supports the Chest X-Ray CAD Display profile supports the storage of CR, DX, Secondary Capture Image Storage SOP Instances and Chest CAD SR SOP instances.

An Evidence Creator that supports the Chest X-Ray CAD Display profile creates a Chest CAD SR SOP instance for each case it processes regardless of findings or not and regardless of being successful or not, and in the case of a failed processing it reports the reasons and sub-categories of failure in the Chest CAD SR SOP instance.

235 **An Image Display that supports the Chest X-Ray CAD Display profile retrieves any Chest CAD SR SOP instances associated with the study under review and renders the respective CAD marks on the corresponding image(s).**

240 **In cases where there is more than one SR for a specific image processed during a CAD session the Image Display shall allow the user to select which SR should be displayed over the image.**

27.4 Chest X-Ray CAD Display Security Considerations

None.

<Appendix A> Actor Summary Definitions

245 *No new actors are defined for this profile.*

<Appendix B> Transaction Summary Definitions

No new transactions are defined for this profile.

Volume 2 – Transactions

250 **Amend section 4.16.3 of Retrieve Images:**

4.16.4.1.3 Expected Actions

...

4.16.4.1.3.1 NM Image Profile

...

255 **4.16.4.1.3.2 Mammography Image Profile**

Image Manager/Image Archive actors supporting the Mammography Image Profile shall support all the SOP Classes specified in Table 4.16.4.1.3.2-1.

Image Display actor supporting the Mammography Image Profile shall support all the SOP Classes specified in Table 4.16.4.1.3.2-1.

260

Table 4.16.4.1.3.2-1. Mammography SOP Classes for Display

SOP Class UID	SOP Class Name
1.2.840.10008.5.1.4.1.1.1.2	Digital Mammography Image Storage – For Presentation

Note that Image Displays are not required to support “For Processing” images.

4.16.4.1.3.3 Chest X-Ray CAD Display Profile

265 **Image Manager/Image Archive actors supporting the Chest X-Ray CAD Display Profile shall support all the SOP Classes specified in Table 4.16.4.1.3.3-1.**

Image Display actors supporting the Chest X-Ray CAD Display Profile shall support all the SOP Classes specified in Table 4.16.4.1.3.3-1.

270

Table 4.16.4.1.3.3-1. Chest X-Ray SOP Classes for Display

<u>SOP Class UID</u>	<u>SOP Class Name</u>
<u>1.2.840.10008.5.1.4.1.1.1</u>	<u>Computed Radiography Image Storage</u>
<u>1.2.840.10008.5.1.4.1.1.1.1</u>	<u>Digital X-Ray Storage – For Presentation</u>
<u>1.2.840.10008.5.1.4.1.1.7</u>	<u>Secondary Capture Image Storage</u>
<u>1.2.840.10008.5.1.4.1.1.7.3</u>	<u>Multiframe Grayscale Word Secondary Capture Image Storage</u>

Note that Image Displays are not required to support “Digital X-Ray Storage – For Processing” images.

Amend section 4.16.4.2.2.1.1.8 :

275 **4.16.4.2.2.1 Display of Digital X-Ray, Mammo and Intra-Oral Images**

...

4.16.4.2.2.1.1 Display of Digital Mammography Images

The contents of this section are required for Image Display claiming the Mammography Image Profile.

280 ...

4.16.4.2.2.1.1.8 Display of Mammography CAD Marks

...

Add section 4.16.4.2.2.1.2:

4.16.4.2.2.1.2 Display of Chest X-Ray Images

285 **The contents of this section are required for an Image Display claiming the Chest X-Ray CAD Display Profile.**

All Chest X-Ray CAD Image Display actors shall support the Retrieve Images transaction for all of the supported SOP Classes listed in Table 4.16.4.1.3.3-1.

290 **The Image Display shall be capable of displaying simultaneously a set of current and prior conventional two view frontal and lateral projection radiographs of the chest images, regardless of whether these images are in one or multiple DICOM Series or Studies, with and without the application of CAD marks.**

Add section 4.16.4.2.2.1.2.1:

295 **4.16.4.2.2.1.2.1 Display of Chest X-Ray CAD Marks**

Image Displays shall be able to apply marks on the displayed image corresponding to all findings encoded in Chest CAD SR objects with a (111056, DCM, “Rendering Intent”) value of (111150, DCM, “Presentation Required”). They may be able to display additional findings that have a (111056, DCM, “Rendering Intent”) value of (111151, DCM, “Presentation Optional”).

300

305 **The Image Display shall make the user aware that CAD marks are available for display, and indicate whether or not CAD marks are currently activated. If more than one set of CAD objects are available that are applicable to the same image (e.g. CAD was run more than once on the same image), then all SRs shall be made available for display at the user’s discretion.**

Whether or not the CAD marks are turned off by default shall be site and user configurable.

310 **The form in which the CAD marks are displayed may influence observer performance, and hence it may be necessary to display them in a manner prescribed by the CAD device vendor, which is not encoded in the DICOM object. The form of the CAD mark rendering is out of the scope of this profile to define.**

The Image Display shall make available for display the following information about each CAD finding, if encoded in the CAD object:

- **Manufacturer (0008,0070)**
- 315 • **Algorithm as defined in (111001, DCM, “Algorithm Name”) and (111003, DCM, “Algorithm Version”)**
- **Operating point as defined in (111071, DCM, “CAD Operating Point”)**
- **Content Date (0008,0023) and Content Time (0008,0033) of the CAD SR instance, if more than one exists and applies to the displayed image**

320 **The Image Display shall indicate when CAD was not attempted or has failed, either entirely, or if some algorithms have succeeded and others failed, as distinct from when CAD has succeeded but there are no findings. This information shall be obtained from the status values of (111064, DCM, “Summary of Detections”) and (111065, DCM, “Summary of Analyses”).**

325

Volume 3 - Transactions

Amend section 4.43.3 Evidence Document Stored Referenced Standards:

4.43.3 Referenced Standards

330 DICOM 2008~~9~~ PS 3.4: Storage Service Class; Basic Text SR SOP Class; Enhanced SR SOP Class; Comprehensive SR SOP Class; Chest CAD SR SOP Class; Mammography CAD SR SOP Class

DICOM 2009 PS 3.16: OB-GYN Ultrasound Procedure Reports; Catheterization Lab SR; Vascular Ultrasound SR; Mammo and Chest CAD SR.

This list is intended to provide a base list of examples. It is expected that DICOM will continue to publish additional SR SOP Classes and Templates appropriate for Evidence Documents.

335

For reference section 4.43.4.1.3 Evidence Document Stored Expected Actions – Chest CAD already there:

4.43.4.1.3 Expected Actions

340 The DICOM Standard defines a number of non-image storage SOP classes that may be used for creation of Evidence Documents. It is expected that the Image Archive will support multiple storage SOP classes as defined in table 4.43-1 below.

Table 4.43-1. Suggested Evidence Document SOP Classes

SOP Class UID	SOP Class Name
1.2.840.10008.5.1.4.1.1.88.50	Mammography CAD SR
1.2.840.10008.5.1.4.1.1.88.11	Basic Text SR
1.2.840.10008.5.1.4.1.1.88.22	Enhanced SR
1.2.840.10008.5.1.4.1.1.88.33	Comprehensive SR
1.2.840.10008.5.1.4.1.1.88.65	Chest CAD SR

345 It is also expected that the Image Archive will support one or more Templates that are defined to be used with the Evidence Documents, as specified in the Table 4.43-2.

Table 4.43-2. Suggested Evidence Document Templates

Template ID	Template Name
TID 4000	Mammography CAD Document Root Template
TID 5000	OB-GYN Ultrasound Procedure Report
TID 3500	Hemodynamics Report

TID 4100	Chest CAD SR Document Root Template
TID 5100	Vascular Ultrasound Procedure Report Template

The Image Archive **must shall** support storage level 2: i.e., all type 3 attributes **must shall** be supported.

350

Add section 4.43.4.1.3.2 to Evidence Document Stored :

4.43.4.1.3.2 Chest X-Ray CAD Display Profile

Evidence Creator (i.e., CAD System) and Image Manager/Image Archive actors supporting the Chest X-Ray CAD Display Profile shall support the Chest CAD SR SOP Class.

355 **The Evidence Creator shall create a Chest CAD SR SOP instance for each case it processes regardless of whether there are findings and regardless of whether the analysis is successful. In the case of a failed processing, the Evidence Creator shall report the reasons and sub-categories of failure in the Chest CAD SR SOP instance.**

360 **Image Manager/Image Archive actors shall not only be able to receive Chest CAD SR SOP Class objects from the Evidence Creator, but also be able to return them in response to queries (i.e., they must actually be stored intact for later retrieval, not merely processed or burned in to images dynamically). See Retrieve Evidence Transaction Section 4.45.4.2.3.2 Chest X-Ray CAD Display Profile.**

365 *Add section 4.44.4.1.3.2 to Query Evidence Documents:*

4.44.4.1.3.2 Chest X-Ray CAD Display Profile

Image Display and Image Manager/Image Archive actors supporting the Chest X-Ray CAD Display Profile shall support the Chest CAD SR SOP Class.

370 *Add section 4.45.4.2.3.2 Retrieve Evidence Documents:*

4.45.4.2.3.2 Chest X-Ray CAD Display Profile

Image Display and Image Manager/Image Archive actors supporting the Chest X-Ray CAD Display Profile shall support the Chest CAD SR SOP Class.

375 **Image Display actors shall be able to apply Chest CAD SR information to displayed images; see 4.16.4.2.2.1.2.1 Display of Chest X-Ray CAD Marks. It is not permitted to ignore data that has a rendering intent of presentation required; there is no such thing as a “low-grade” rendering for Chest CAD SR.**