

Integrating the Healthcare Enterprise



5

IHE ITI
Technical Framework Supplement

10

Mobile Cross-Enterprise
Document Data Element Extraction
(mXDE)

15

Rev. 1.1 – Trial Implementation

20 Date: August 4, 2017
Author: IHE ITI Technical Committee
Email: iti@ihe.net

25

Please verify you have the most recent version of this document. See [here](#) for Trial Implementation and Final Text versions and [here](#) for Public Comment versions.

Foreword

30 This is a supplement to the IHE IT Infrastructure Technical Framework V14.0. Each supplement
undergoes a process of public comment and trial implementation before being incorporated into
the volumes of the Technical Frameworks.

This supplement is published on August 4, 2017 for trial implementation and may be available
for testing at subsequent IHE Connectathons. The supplement may be amended based on the
results of testing. Following successful testing it will be incorporated into the IT Infrastructure
35 Technical Framework. Comments are invited and can be submitted at
http://www.ihe.net/ITI_Public_Comments.

This supplement describes changes to the existing technical framework documents.

“Boxed” instructions like the sample below indicate to the Volume Editor how to integrate the
relevant section(s) into the relevant Technical Framework volume.

40

<i>Amend Section X.X by the following:</i>
--

Where the amendment adds text, make the added text **bold underline**. Where the amendment
removes text, make the removed text **~~bold strikethrough~~**. When entire new sections are added,
introduce with editor’s instructions to “add new text” or similar, which for readability are not
bolded or underlined.

45

General information about IHE can be found at <http://ihe.net>.

Information about the IHE IT Infrastructure domain can be found at http://ihe.net/IHE_Domains.

Information about the organization of IHE Technical Frameworks and Supplements and the
process used to create them can be found at http://ihe.net/IHE_Process and <http://ihe.net/Profiles>.

50 The current version of the IHE IT Infrastructure Technical Framework can be found at
http://ihe.net/Technical_Frameworks.

55 **CONTENTS**

	Introduction to this Supplement.....	4
	Open Issues and Questions	6
	Closed Issues.....	6
60	General Introduction	11
	Appendix A – Actor Summary Definitions	11
	Appendix B – Transaction Summary Definitions.....	11
	Glossary	11
	Volume 1 – Profiles	12
65	45 Mobile Cross-Enterprise Document Data Element Extraction (mXDE) Profile.....	12
	45.1 mXDE Actors, Transactions and Content Modules.....	15
	45.1.1 Actor Descriptions and Actor Profile Requirements.....	17
	45.1.1.1 Data Element Extractor	17
	45.1.1.2 Data Element Provenance Consumer	17
70	45.2 mXDE Actor Options.....	18
	45.2.1 Data Element Extractor Actor Options	18
	45.2.1.1 XDS Document Registry Integration	18
	45.2.1.2 MHD Document Responder Integration	18
	45.2.2 Data Element Provenance Consumer Actor Options	19
75	45.2.2.1 XDS Document Consumer Integration	19
	45.2.2.2 MHD Document Consumer Integration	19
	45.3 mXDE Required Actor Groupings.....	19
	45.4 mXDE Overview.....	20
	45.4.1 Concepts	20
80	45.4.2 Use Cases	20
	45.4.2.1 General Use Case	20
	45.4.2.1.1 General Use Case Description	21
	45.4.2.1.2 Process Flow	22
	45.5 mXDE Security Considerations	24
85	45.5.1 mXDE integrity and credibility of information accessed.....	24
	45.6 mXDE Cross Profile Considerations	25
	45.7 Deployment Models.....	25
	45.7.1 mXDE Deployment Model A - Central Document Registry/Repository and Central Fine-Grained Data Source	26
90	45.7.2 mXDE Deployment Model B - Distributed Document Repository and Central Fine-Grained Data Source.....	27
	Volume 2 – Transactions	29
	3.43 Retrieve Document Set	29
	3.43.1 Scope	29
95	3.43.2 Use Case Roles.....	30
	Volume 3 – Content Modules.....	32

Introduction to this Supplement

100 The Mobile Cross-Enterprise Document Data Element Extraction (mXDE) Profile provides the means to access data elements extracted from shared structured documents. The profile enables the deployment of health data exchange infrastructures where fine-grained access to health data coexists and complements the sharing of coarse-grained documents and the fine-grained data elements they contain.

105 This profile is based on the reality that health information sharing relies on different granularities of exchange:

- 110 • **Document-Level Granularity:** Share and access documents as a composition of various data elements to reflect the information known and produced during a care or administrative workflow steps. This level of granularity is optimum to ensure that contained data has clarity of context in care delivery and reflects source attestation (responsibility) of clinical data shared.
- 115 • **Data Element-Level Granularity:** Access a specific type of data elements (e.g., vitals signs, medications, etc.). This level of granularity is optimum when a list of data elements relevant to a “time span” or a set of encounters is of interest. Examples of situations where this level of granularity may be optimum include access to a list of allergies at the time of medication dispensation, or information reconciliation at the time of hospital admission.

Each granularity level delivers unique benefits and this profile provides efficient access to both levels.

120 The sharing of documents across community/regional/national health information exchange platforms is one of the fundamental paradigms of exchange of health records. Currently, these kinds of records are often shared using IHE profiles such as: Cross-Enterprise Document Sharing (XDS), Cross-Community Document Access (XCA), and Mobile access to Health Documents (MHD with XDS on FHIR^{®1}).

125 However, many health information exchange platforms that support document sharing are considering extending their services by offering cross-document data aggregation. This can be addressed, in part, with the access to documents created on-demand with the On-Demand Document Source in the XDS Profile, and, in part, with profiles such as PCC’s Query for Existing Data for Mobile (QEDm) Profile that supports the granular access to specific data elements (e.g., list of medications, list of allergies).

130 The mXDE Profile allows an integrated approach to health records by using existing services from the IHE profiles mentioned above.

¹ FHIR is the registered trademark of Health Level Seven International.

The mapping of the document content to data elements is outside the scope of this profile. It needs to be specified for each deployment based on the specific document content and data elements managed.

135

Open Issues and Questions

None

Closed Issues

140 **mXDE_102: Should other Deployment Models be considered besides the two described in Section 45.7, if any?**

Resolution:

⇒ *The two models provided seem sufficient. During trial implementation the need to add other deployment models to Section 45.7 may be considered.*

145 **mXDE_103: Integration of a document sharing environment where an XDS Document Consumer is grouped with a Data Element Extractor.**

The need to introduce an actor grouping option where an XDS Document Consumer is grouped with the Data Element Extractor to gain access to documents content and extract data elements along with creation of Provenance Resources has been considered (See diagram).

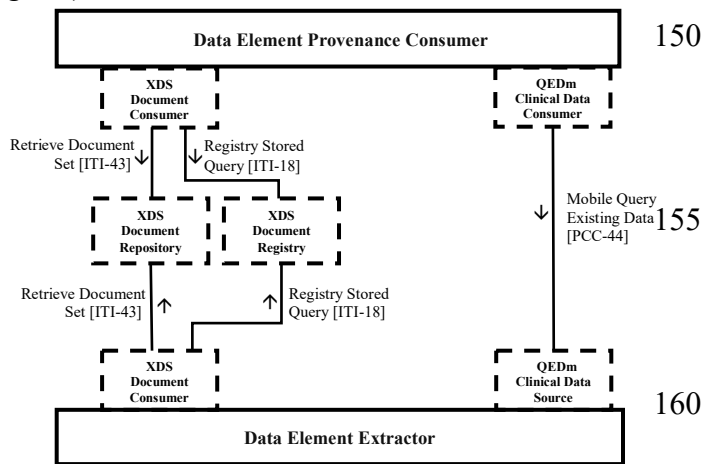

150 Given the “pull” behavior of the XDS Document Consumer and the need to limit the update delays for the Data Element Extractor, it has been considered that the introduction of such an option needs further study. Feedback from implementers during Trail Implementation may result in input to address the architectural challenges of such a grouping.

155

160

PROS: this option would allow a Data Element Extractor to be an independent product from the XDS Document Registry, and to be able to work in both XDS and XCA environments.

165 **CONS:** this approach would likely be less efficient than the already document option integrating with a Document Registry. It might be possible to mitigate some of those inefficiencies through document subscriptions and content prefetching.

Resolution:

170 ⇒ *Not introduce that option in the trial implementation version of mXDE. Experience gained through trial implementation may provide input on the need of this additional grouping option.*

175 ***mXDE_101: The actor diagram is shown as three alternative groupings of actors. Should we simplify the presentation by showing a single diagram and include some text explaining the choices that are introduced later as options?***

Resolution:

⇒ ***Implementers are likely to choose one of these alternative groupings. It was felt simpler for the readers to keep these diagrams distinct.***

180 ***mXDE_201: how to manage fine-grained data 'Location' and Reconciliation in an Affinity Domain with N Repositories?***

We are defining a data locator service that allows to collect all the fine-grained information of interest by querying in a 'central point'.

Case #1: 1 XDS Registry + 1 XDS Repository (& Fine-Grained Data Repository)

- 185
- the Clinical Data Source can be providing data elements resources as the central point for querying & retrieving ALL fine-grained data
 - Reconciliation may be placed at this central point.
- ⇒ OK (for centralized reconciliation & access)

190 **Case #2: 1 XDS Registry (with a central Clinical Data Source or Fine-Grained Data Repository) + N XDS Repositories**

- The unique XDS Registry still works well as master top-level index for coarse-grained XDS Documents,
 - The Clinical Data Source & Reconciliation grouped with the Registry/Responder still works well as a central point to query/access fine-grained information.
- 195
- The Clinical Data Source is grouped with a Document Consumer to access and extract data elements out of documents content from the N Document Repositories, each providing a subset of the data (this may happen with caching when new documents are registered or on demand when the Clinical Data Source is queried for data elements.

200 **Case #3: 1 XDS Registry + N XDS Repository (Each with a Clinical Data Source or Fine-Grained Data Repository)**

- The unique XDS Registry still works well as master top-level index for coarse-grained XDS Documents, but there is no longer have a central point to query/access fine-grained information.
- 205
- When the Clinical Data Source Actors placed at the level of each Doc Repository, each provides a subset of the data

- 210
- This case raises two issues:
 - The Clinical Data Sources are no longer unique. Is that an issue? It may imply that some deduplication/reconciliation may be necessary by the Clinical Data Consumers
 - This deployment requires specific behavior from the Clinical Data Consumers to locate the various Clinical Data Sources.

Resolution:

215 ⇒ *When multiple Doc Repositories in an affinity domain deployment, Case 2 should be supported, but case #3 appears to be a very particular case that need not be covered by mXDE. Case #1 and # 2 will be the two deployment models to be discussed in an informative section (See Section 45.7 on Deployment Models).*

mXDE_202: Is fine-grained content always derived/derivable from Documents?

220 mXDE assumes that the shared Repository/Registry is being fed by document sources with documents that are shared.

The data elements contained in these documents is offered for data element level query and extracted as a Clinical Data Source and delivered as query responses to clinical data consumers.

225 Is this the only input that is used?

Couldn't we consider fine-grained data elements that have not be created/shared through the provide and register of documents?

This was already considered in the on-demand documents option of XDS.

230 Another way to ask the same question, is whether the mXDE Profile should be limited to consider fine-grained content derived/derivable from Documents that are persisted in a certain XDS Repository?

Resolution:

⇒ *It is allowed in mXDE to have data elements not coming from documents. Impacts of such flexibility will be analyzed (e.g., impact on privacy).*

235 **mXDE_203: Privacy and BPPC consent policies**

Any specification about privacy?

It is necessary to provide some “guidance”, but no need for a solution as this would be the topic of the grouping of mXDE with existing or future privacy IHE profiles.

The grouping with existing profiles may be of interest.

240 **Resolutions:**

⇒ *To apply the existing BPPC/APPC consent from the source document to each “fine-grained” element (privacy properties inheritance). This may be a simple and effective way to ensure consistent policies for both document-level and fine-grained data element level access.*

245 ⇒ *For fine-grained data elements not coming from documents it’s suggested to consider a new BPPC/APPC consent for specifying if someone can query or not for a certain category of information (e.g., consent to access the Vital Signs)*

mXDE_204: Integrity and credibility of information accessed

250 The profile provides a controlled approach to access the same health information either in a document level coarse grain level granularity or in a fine-grained data element granularity.

The relationship between these two levels results in a number of situations that could result in “defects in information integrity and/or credibility in the information being accessed. The following points should be discussed in the profile:

- 255 1. Different forms of mappings may have to be performed. Although it is beyond the scope of the mXDE Profile to specify such mapping between data elements in documents and fine-grained data elements accessed directly, it is important that implementers note that:
 - a. Such mappings may not be perfect (typical limitations in semantic mappings).
 - b. Some information contained in the documents may not be “expressed” as data elements (e.g., textual elements) and be “lost” in the data element queries vs the documents
- 260 2. Some sources that have “signed” a document may object that it is “taking apart in data elements” having the data elements taken out of the context offered by the document. These data elements may not be made visible in the data element granularity queries. Include examples: non-coded information is critical to interpret the coded information, constraint on use (e.g., document for display only), a treatment with stress induced that results non-generic vital signs. In all of those context is key to correct clinical interpretation.
- 265 3. mXDE is designed to “limit” these above issues, by offering the means to avoid these weaknesses of the “data element granularity”, by allowing the user that gets from a query lists of data elements, to easily request the document(s) that are sources of any of those fine-grained data element of interest.
- 270

Resolution:

⇒ *The profile will provide a good discussion on the above issues and “guidance” on the profile to help implementers of the profile.*

275 ***mXDE_205: Check/add the key requirements to ensure that health data is consistently exchanged at different level of granularity***

The following points of consistency seem to be most important:

- *When a data element is accessed by a Clinical Data Consumer and found relevant, one need to offer a simple way to extract:*
 - *Identifiers from the data element in order to access one or more documents in which this item was initially shared.*
 - *Use the above identifiers to access these documents content and “related” items that may have been shared.*
- *Some of those ‘identifiers’ may also be needed for clinical decision traceability.*

280

285

Resolution:

- ⇒ ***mXDE shall precisely define the identifiers that grant consistency between documents and/or fine-grained data elements (e.g., from data element → discover the document from which the resource is extracted). The concept of a Provenance Resource is profiled by mXDE to address these requirements.***

290

General Introduction

Update the following Appendices to the General Introduction as indicated below. Note that these are not appendices to Volume 1.

Appendix A – Actor Summary Definitions

295 *Add the following actors to the IHE Technical Frameworks General Introduction list of actors:*

Data Element Extractor – The Data Element Extractor extracts data elements from documents along with the associated provenance information that traces back to the source document.

Data Element Provenance Consumer – The Data Element Provenance Consumer uses the provenance information associated with data elements to access the source information.

300 Appendix B – Transaction Summary Definitions

Add the following transactions to the IHE Technical Frameworks General Introduction list of Transactions:

Not applicable

305 Glossary

Add the following glossary terms to the IHE Technical Frameworks General Introduction Glossary:

No new terms added.

Volume 1 – Profiles

310 *Add Section 45*

45 Mobile Cross-Enterprise Document Data Element Extraction (mXDE) Profile

315 The Mobile Cross-Enterprise Document Data Element Extraction (mXDE) Profile provides the means to access data elements extracted from shared structured documents. The profile enables the deployment of health data exchange infrastructures where fine-grained access to health data coexists and complements the sharing of coarse-grained documents and the fine-grained data elements they contain.

This profile is based on the reality that health information sharing relies on different granularities of exchange:

- 320 • **Document-Level Granularity:** share and access documents as a composition of various data elements to reflect the information known and produced during a care or administrative workflow step. This level of granularity is optimum to ensure that contained data has clarity of context in care delivery and reflects source attestation (responsibility) of clinical data shared.
- 325 • **Data Element-Level Granularity:** access a specific type of data element (e.g., vital signs, medications, etc.). This level of granularity is optimum when the list of data elements relevant to a “time span” or a set of encounters is of interest. Examples of situations where this level of granularity may be optimum include access to a list of allergies at the time of medication dispensation, or information reconciliation at the time
- 330 of hospital admission.

Each granularity level delivers unique benefits and this profile provides efficient access to both levels.

335 This profile defines rules to ensure consistency and traceability of information used for clinical decisions. When a data element is accessed by a Clinical Data Consumer, identifiers from that data element can be used to access one or more documents in which this data element was originally recorded, providing a valuable broader clinical context.

Profile Introduction and Concepts

340 The sharing of documents across community, regional, or national health information exchange platforms is one of the fundamental paradigms of exchange of health records. Currently, these kinds of records are often shared using IHE profiles such as Cross-Enterprise Document Sharing (XDS), Cross-Community Document Access (XCA), and Mobile access to Health Documents (MHD).

345 However, many health information exchange platforms that support document sharing are considering extending their services by offering cross-document data aggregation. This can be addressed, in part, with the access to documents dynamically created with the On-Demand Document Source in the XDS Profile, and, in part, with profiles such as PCC’s Query for Existing Data for Mobile (QEDm) Profile that supports the granular access to specific data elements (e.g., list of medications, list of allergies).

350 The mXDE Profile takes it one step further. It allows an integrated approach to health records by using existing services from the IHE profiles mentioned above.

The mapping of the document to data elements is outside the scope of the mXDE Profile. It needs to be specified for each deployment based on the specific document content and data elements managed.

355 Figure 45-1 conceptually depicts the sharing of health information supported by mXDE, highlighting that health information could be shared at different levels of granularity: Document-Level Granularity (shown with the green documents) and the Data Element-Level Granularity (shown with orange hexagons). The health data exchange infrastructure depicted as a “hub” in the middle is providing a location service to access both document-level or data element-level health data in a patient-centric manner.

360

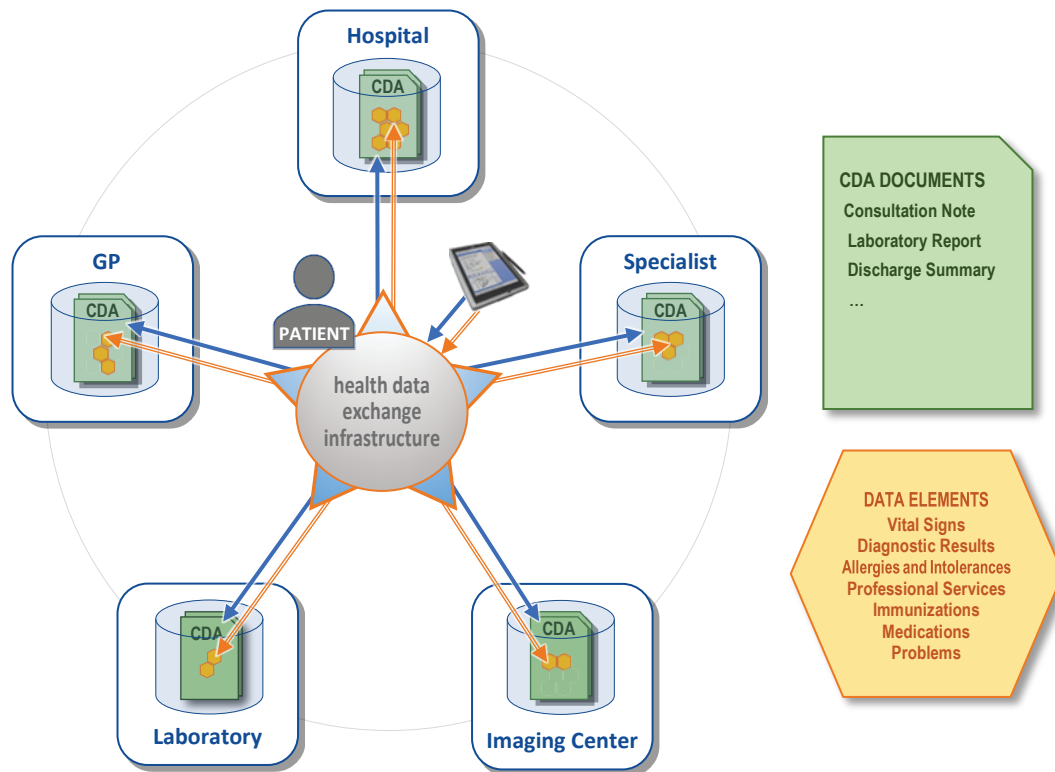

Figure 45-1: mXDE environment and multilevel granularity access to health information

365 Figure 45-2 below, depicts a deployment of the mXDE Profile which can support the environment in Figure 45-1 above. It illustrates one possible combination of mXDE actors (Data Element Extractor and Data Element Provenance Consumer) with actors and transactions from the MHD, XDS and QEDm IHE Profiles.

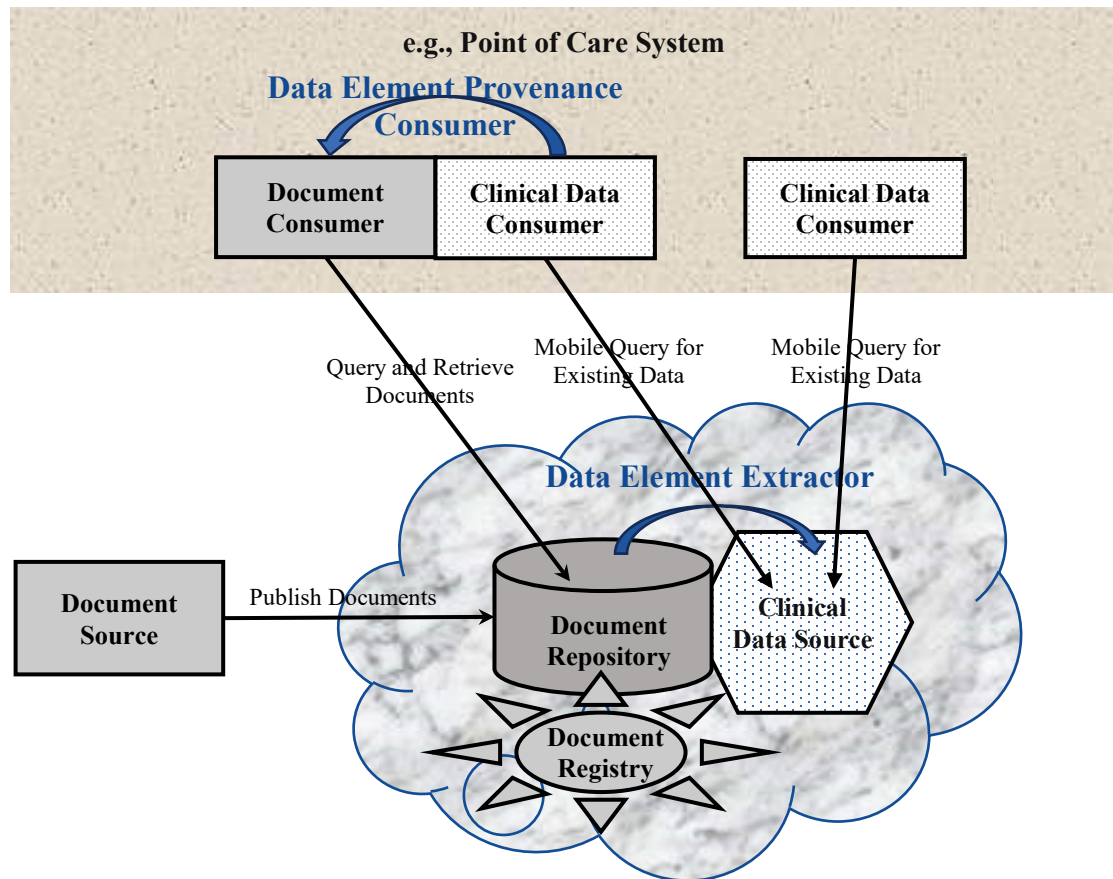

Figure 45-2: mXDE Profile combining actors and transactions of other IHE Profiles

- 370
- Document-Level Granularity “publication” is out of scope of this profile but may be performed using the XDS Provide and Register [ITI-41] transaction, the MHD Provide Document Bundle [ITI-65] transaction or other means.
 - Data Element-Level Granularity access is central to mXDE and is discussed in Section 45.1. The Provenance information, returned with each fine-grained data element in the Query responses, allows identification of the document from which the fine-grained data element was extracted.
 - Document-Level Granularity “consumption” is central to mXDE and is discussed in Section 45.1. Using the identification of the document from which a data element was extracted, it is possible to access the clinical context in which that data element was observed.
- 375

380 This profile supports a variety of deployment models. Two of those are discussed in Section 45.7

45.1 mXDE Actors, Transactions and Content Modules

This section defines the actors, transactions, and/or content modules in this profile. General definitions of actors are given in the Technical Frameworks, General Introduction, Appendix A at http://ihe.net/TF_Intro_Appendices.aspx.

385 The mXDE Profile includes two actors:

- The **Data Element Extractor Actor** accesses documents to extract data elements and create the links to the data elements' source documents.
- The **Data Element Provenance Consumer Actor** uses the provided links from data elements to source documents to obtain broader clinical context in which the data elements were recorded.

390

Three alternative groupings of actors are supported by mXDE. Each one is depicted by a separate figure below that shows the actors directly involved in the mXDE Profile and the relevant transactions between them. These groupings are further specified in Section 45.3.

Grouped actors are shown with conjoined boxes. The actors shown with dotted line boxes are specified by other IHE profiles.

395

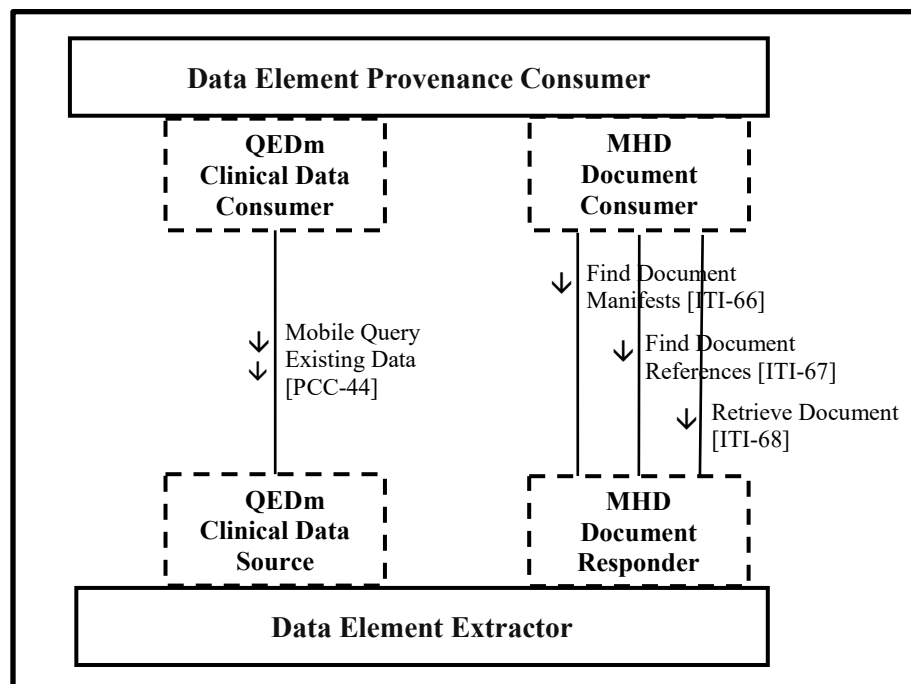

Figure 45.1-1: mXDE Actor Diagram with QEDm and MHD

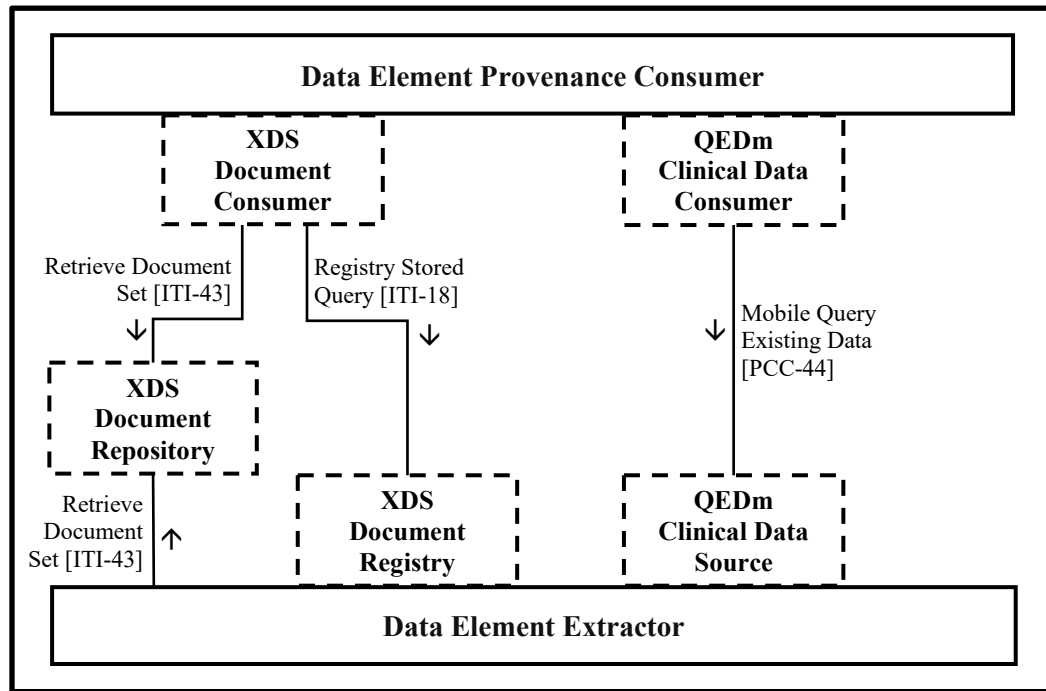

Figure 45.1-2: mXDE Actor Diagram with QEDm and XDS

400

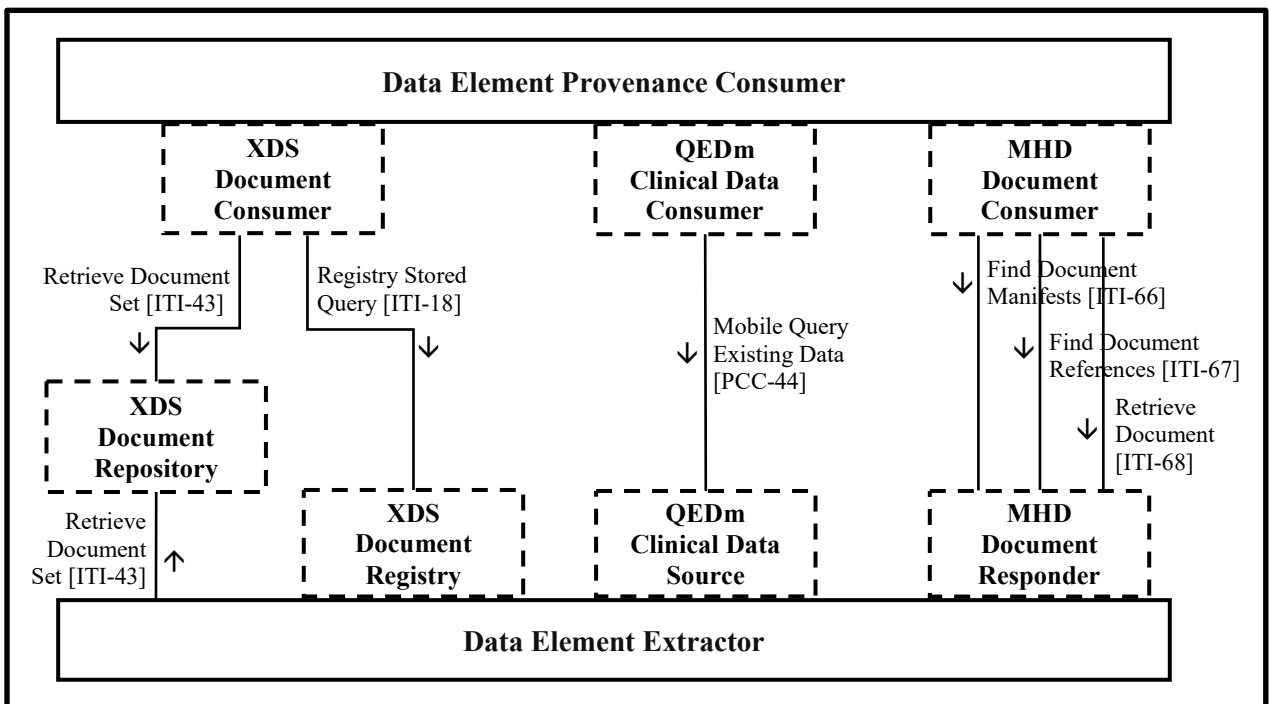

Figure 45.1-3: mXDE Actor Diagram with QEDm, XDS and MHD

Table 45.1-1 lists the transactions for each actor directly involved in the mXDE Profile.

Table 45.1-1: mXDE Profile - Actors and Transactions

Actors List	Transactions	Optionality	Reference
Data Element Extractor	Retrieve Document Set [ITI-43]	O (See Note 1)	ITI TF-2b: 3.43
Data Element Provenance Consumer	None	-	-

405 Note 1: This transaction is required if the Data Element Extractor supports the XDS Document Registry Integration Option. See Section 45.2.1.1.

45.1.1 Actor Descriptions and Actor Profile Requirements

45.1.1.1 Data Element Extractor

The Data Element Extractor:

- 410
- Shall access documents, through:
 - a grouped XDS Document Registry and the Retrieve Document Set [ITI-43] transaction, or
 - a grouped MHD Document Responder.
 - Shall extract the data element information from the retrieved documents
- 415
- Shall obtain the provenance information and create an HL7^{®2} FHIR Provenance Resource associated with extracted data elements (see PCC QEDm Trial Implementation Supplement, Volume 2, Section 3.44.4.2.2.1 “Resource Specific Contents”).
 - Shall make the Provenance Resource available to the grouped PCC QEDm Clinical Data Source using the Document Provenance Option. This allows provenance information to
- 420
- be returned in its query responses along with the extracted data elements.

45.1.1.2 Data Element Provenance Consumer

The Data Element Provenance Consumer:

- 425
- Shall be grouped with a QEDm Clinical Data Consumer using the Document Provenance Option. The Clinical Data Consumer retrieves data elements together with the provenance information through the Mobile Query Existing Data [PCC-44] transaction.
 - Shall be capable of using the provenance information returned in responses to access source documents through:
 - a grouped XDS Document Consumer, or

² HL7 is the registered trademark of Health Level Seven International.

- a grouped MHD Document Consumer.

430 45.2 mXDE Actor Options

Options that may be selected for each actor in this profile, if any, are listed in the Table 45.2-1. Dependencies between options when applicable are specified in notes.

Table 45.2-1: mXDE – Actors and Options

Actor	Option Name	Reference
Data Element Extractor	XDS Document Registry Integration (Note 1)	Section 45.2.1.1
	MHD Document Responder Integration (Note 1)	Section 45.2.1.2
Data Element Provenance Consumer	XDS Document Consumer Integration (Note 2)	Section 45.2.2.1
	MHD Document Consumer Integration (Note 2)	Section 45.2.2.2

435 Note 1: The actor shall implement at least one of the options XDS Document Registry Integration or MHD Document Responder Integration

Note 2: The actor shall implement at least one of the options XDS Document Consumer Integration or MHD Document Consumer Integration.

45.2.1 Data Element Extractor Actor Options

45.2.1.1 XDS Document Registry Integration

440 The support of this option by a Data Element Extractor enables:

- extracting data elements contained in documents stored in an XDS Document Repository;
- tracking of document provenance for the extracted data elements through references to source documents managed by the XDS Document Registry.

The Data Element Extractor that supports this option:

- 445
- shall be grouped with an XDS.b Document Registry;
 - shall make available data elements extracted from documents that are known to the Document Registry;
 - shall be able to retrieve documents from an XDS.b Document Repository using the Retrieve Document Set [ITI-43] transaction.

450 45.2.1.2 MHD Document Responder Integration

The support of this option by a Data Element Extractor enables:

- extracting data elements contained in documents provided by the MHD Document Responder;

- 455
- tracking of document provenance for the extracted data elements through references to source documents provided by the MHD Document Responder.

The Data Element Extractor that supports this option:

- shall be grouped with an MHD Document Responder;
 - shall make available data elements extracted from documents that are known to the MHD Document Responder;
- 460
- shall obtain documents from the grouped MHD Document Responder.

45.2.2 Data Element Provenance Consumer Actor Options

45.2.2.1 XDS Document Consumer Integration

The support of this option enables a Data Element Provenance Consumer to access the referenced source documents managed by the XDS Document Registry and Repositories.

465 The Data Element Provenance Consumer that supports this option:

- shall be grouped with an XDS Document Consumer and thus be capable of accessing the documents referenced by any Provenance Resource.

45.2.2.2 MHD Document Consumer Integration

470 The support of this option enables a Data Element Provenance Consumer to access the referenced source documents managed by the MHD Document Responder.

The Data Element Provenance Consumer that supports this option:

- shall be grouped with an MHD Document Consumer and thus be capable of accessing the documents referenced by any Provenance Resource.

45.3 mXDE Required Actor Groupings

475 An actor from this profile (Column 1) shall implement all required transactions for the grouped actor (Column 3) in the Required Actor Groupings Table as shown below.

Note that each one of the three alternatives of actor diagrams specified for the mXDE Profile in Section 45.1 has different required actor groupings.

Table 45.3-1: mXDE Profile - Required Actor Groupings

mXDE Actor	Grouping Condition	Actor(s) to be grouped with	Reference
Data Element Extractor	Required	PCC QEDm / Clinical Data Source with the Document Provenance Option	PCC TF-1: X.1.1.1 PCC TF-1: X.2.2.9 (Note 1)
	Required	ATNA / Secure Node or Secure Application	ITI TF-1: 9

mXDE Actor	Grouping Condition	Actor(s) to be grouped with	Reference
	If the MHD Document Responder Integration Option is supported.	MHD / Document Responder	ITI TF-1: 33 (Note 2)
	If the XDS Document Registry Integration Option is supported.	XDS / Document Registry	ITI TF-1: 10
Data Element Provenance Consumer	Required	PCC QEDm / Clinical Data Consumer with the Document Provenance Option	PCC TF-1: X.1.1.2 PCC TF-1: X.2.1.9 (Note 1)
	If the MHD Document Consumer Integration Option is supported.	MHD / Document Consumer	ITI TF-1: 33 (Note 2)
	If the XDS Document Consumer Integration Option is supported.	XDS / Document Consumer	ITI TF-1: 10

480 Note 1: Currently in the PCC QEDm Trial Implementation Supplement

Note 2: Currently in the MHD Trial Implementation Supplement

Section 45.5 describes some optional groupings that may be of interest for security considerations and Section 45.6 describes some optional groupings in other related profiles.

45.4 mXDE Overview

485 45.4.1 Concepts

See “Profile Introduction and Concepts” in Section 45.

45.4.2 Use Cases

490 The use case below assumes that every consumer device (mobile or not) knows or discovers the patient identity. The patient identity could be obtained through a transaction in an IHE Profile such as PDQ, PDQV3, PDQm, PIX, PIXV3, or PIXm, or it could simply be entered via some device interface (RFID, Bar-Code, etc.) or user interface, or it could be specified in a configuration setting (e.g., mobile PHR application).

45.4.2.1 General Use Case

495 A human using a consumer device needs to discover the available information of a certain patient and to retrieve the parts of interest in order to get coarse and fine-grained data based on the patient identity and on certain search criteria.

45.4.2.1.1 General Use Case Description

500 A patient encounters his family physician who advises him to make an appointment for a surgical procedure. Consequently, the family physician produces and shares a Transfer of Care document in an XDS Affinity Domain. He also shares a Pharmacy Prescription document.

Following the encounter, the patient makes an appointment with the local hospital for the intended surgery. He also picks up his prescribed medication at the local pharmacy which results in the pharmacy sharing a Pharmacy Dispensation document.

Back at home, the patient uses his smart phone to:

- 505
1. Access the recent prescription and recently dispensed medications to review the dosage and timing for his medication. For this, the prescription information is accessed by the patient portal app on his smartphone.

However, the patient's condition worsens, resulting in an emergency hospitalization.

At the emergency department, the emergency physician:

- 510
2. Urgently needs to stabilize the patient and seeks to obtain his current medication list (the medications prescribed and dispensed need to be extracted from at least two documents).
 3. Decides to complete the patient admission and to schedule the intended surgery. For this, he retrieves the Transfer of Care document.

At the surgery department, the anesthesiologist:

- 515
4. While preparing for the surgery, obtains the history of prescribed and dispensed medications and the list of known allergies (the allergies need to be extracted for the past 10 years from all shared documents for the patient).

At the conclusion of the hospital stay, the attending physician and other health professionals create and share the Discharge Summary document.

520 Back at home, the patient wants to review the Discharge Summary associated with his surgery. He opens the patient portal app on his smart phone, through which he:

- 525
5. Queries the Document Registry to list the recent documents shared for him and retrieves the selected Discharge Summary. The patient can read the recommendations on discharge and the new pharmacy prescription including related dosage. Based on this information, he decides to consult the family physician again for clarification.

Later, in order to better evaluate the results, the family physician needs to check the improvements of patient health. The family physician uses his tablet to:

- 530
6. Query and access all the patient's vital signs and medications (directly as fine-grained data elements) with related provenance information.
 7. In order to reconstruct the patient's history about the cured pathology, each time he finds relevant changes in the patient's history, he uses the provenance information to identify any original document and eventually retrieves it. The document in which the original

data was initially shared makes him understand the context at that time (other findings, observations, etc.) to better evaluate the meaning of fine-grained information.

535 This analysis helps the family physician to improve the care plan for the patient.

45.4.2.1.2 Process Flow

540 Figure 45.2.1.2-1 illustrates the Use Case and assumes some possible actor groupings based on the scenario described. In particular, it assumes that a consumer application running on a mobile device (e.g., the patient’s smartphone and the family physician’s tablet) supports IHE actors designed for mobile use including, but not limited to, the MHD Document Consumer and the QEDm Clinical Data Consumer Actors. However, different actor groupings could be conceived. The only required groupings in the mXDE Profile are those specified in Section 45.3.

Note: “Data Element” is abbreviated “DE” in the diagram below.

IHE IT Infrastructure Technical Framework Supplement – Mobile Cross-Enterprise Document Data Element Extraction (mXDE)

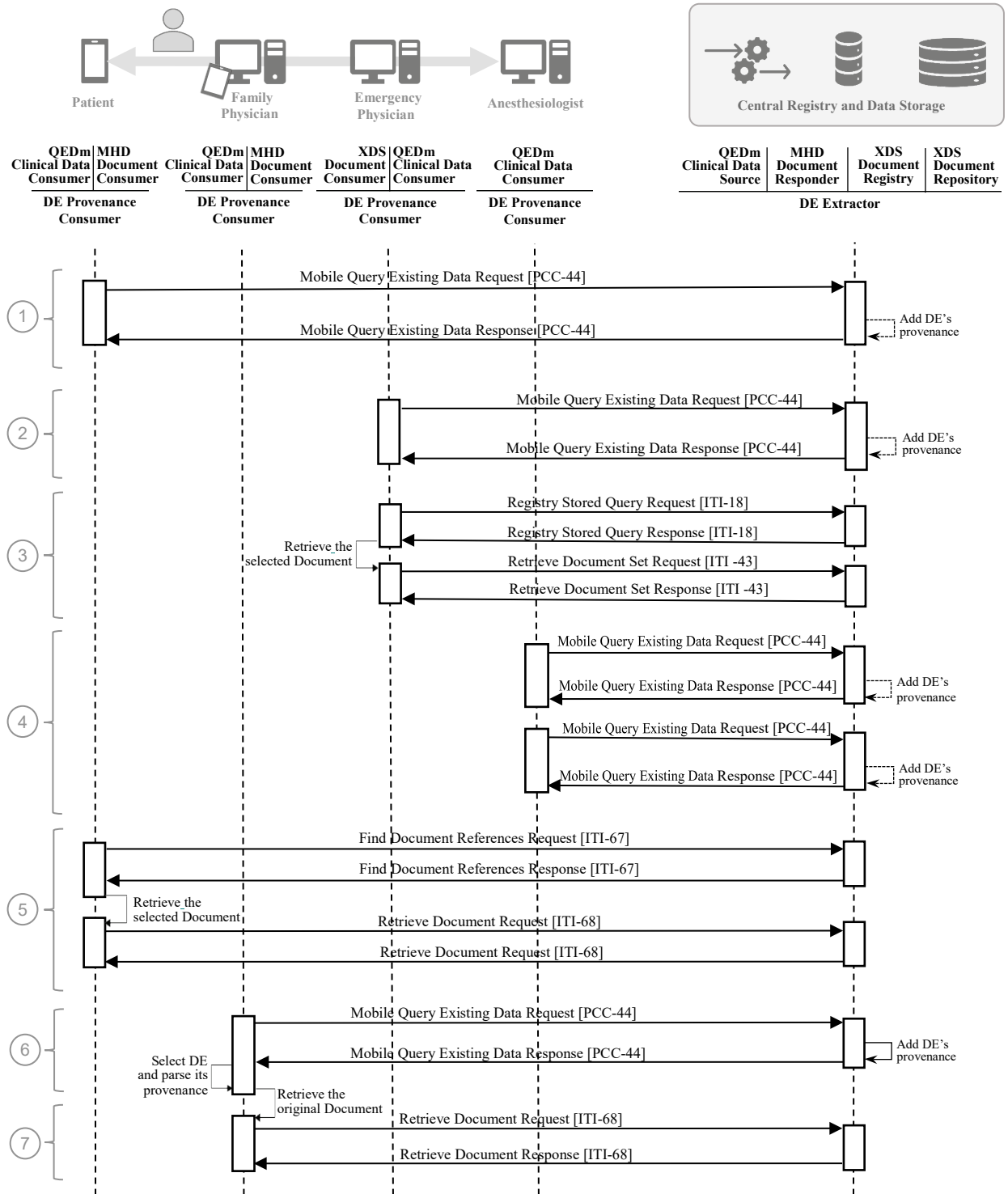

Figure 45.4.2.1.2-1: Basic Process Flow in mXDE Profile

545 **45.5 mXDE Security Considerations**

mXDE is a profile that supports the deployment of a system of systems, thus the security considerations should take into account the overall system design and also the interactions between actors that make up that system. The Security Considerations sections in the underlying QEDm, MHD, XDS Profiles, should also be taken into account in the system design and
550 operational deployment.

IHE security profiles (e.g., ATNA, XUA, IUA, BPPC, APPC) provide functionality to aid with security and privacy. However, the interactions between various environments such as IUA and XUA can be challenging. XUA is used in the XDS environment and is based on SAML. IUA is used in QEDm and MHD environments and is based on OAuth technology. Bridging between
555 these technologies is possible, but is not specified by this profile because bridging depends on specific deployment context.

The mXDE Data Element Extractor will often need to have an XUA identity by which it accesses documents for extraction. This identity would have broad read-only access to documents so that it can extract information. Yet when a Data Element Provenance Consumer queries for data-elements or documents, it will identify a user (e.g., clinician, patient, or
560 organization). The queries would need to be mediated by access control decisions and enforcement that are appropriate. For example, when there is a document-level consent (e.g., BPPC, APPC, or other) and there is a consent restriction that is specified to denying a designated user access, then when that designated user attempts to access data-elements, the access needs to
565 be denied. The solution is a policy and design challenge not addressed by this profile because it depends on specific deployment context.

The provenance solution included in mXDE and QEDm can be used by an access control decision engine. Given any data-element that might be returned on a query, the associated Provenance Resource includes traceability to the Document from which that data-element came.
570 Thus, an access control decision that needs to filter out specific documents can use the Provenance information to determine the results that must be eliminated from the Bundle before the Bundle can be returned to the Data Element Provenance Consumer. The specific use of Provenance in access control decisions, and enforcement is a policy and design challenge not addressed by the QEDm Profile.

575 The Data Element Extractor, and actors with which it is grouped, is grouped with an ATNA Secure Node or Secure Application to provide logging and other security features (see ITI TF-2a: 3.20). It is recommended that the Data Element Provenance Consumer be grouped with an ATNA Secure Node or Secure Application

45.5.1 mXDE integrity and credibility of information accessed

580 The mXDE Profile provides a controlled approach to access the same health information either in a document-level (coarse grain) granularity or in a data element level granularity (fine-grain). In some situations, the relationship between these two levels could result in defects in information integrity and/or credibility in the information being accessed.

The implementer of this profile should consider the following specific issues:

- 585
1. Different forms of mappings may have to be performed when actor groupings have been implemented (it is beyond the scope of the mXDE Profile to specify mapping between data elements in documents and data elements accessed directly) and the consequences need to be accounted for:
 - a) Such mappings may not be perfect (typical limitations in semantic mappings).
 - 590 b) Some information contained in the documents may not be “expressed” as data elements (e.g., textual elements) and will be unavailable in the data element queries
 2. Some document authors that have approved or signed a document, may object to individual data elements being extracted from the overall document context. The data elements from such documents would not be visible at the data element level of access.

595 Examples when such a situation arises are:

 - a) non-coded information is critical to interpret the coded information,
 - b) constraints that require that specific information be only for display but excluded from being copied or imported,
 - 600 c) a treatment summary with a stress induced test that results in “unusual” vital signs-in this context.

mXDE is designed to limit the above issues. It offers the means to avoid these weaknesses of the data element granularity by allowing the user that retrieves a query list to easily request the document(s) that are sources of the data element(s) of interest.

45.6 mXDE Cross Profile Considerations

605 ITI PIX - Patient Identity Cross Referencing and ITI PDQ - Patient Demographics Query

An mXDE Data Element Provenance Consumer may be grouped with a Patient Identifier Cross-reference Consumer in the PIX, PIXV3, or PIXm Profiles or with a Patient Demographics Consumer in the PDQ, PDQV3, or PDQm Profiles to resolve patient identifiers prior to submitting QEDm, XDS or MHD queries.

610 45.7 Deployment Models

For the implementation of the mXDE Profile, a number of actors that generally are considered as part of a health information sharing infrastructure may be organized in various architectural structures. Two deployment models are identified for information in this section. These are not exhaustive and other variants may be supported.

- 615 In each one of these two deployment models, the “interoperability” defined by the mXDE transactions is the same.

Here are the main data flows described for each model:

1. Providing documents
- 620 2. Accessing data element content and if desired one or more of the documents from which a data element was extracted. This access uses the document references conveyed in a Provenance Resource associated with the data element.

The systems involved in each deployment model are represented by grey boxes. The actors implemented are listed below.

625 For simplicity, the flow diagrams use generic names for transactions that can be easily associated with the IHE transactions supported by the implemented actor.

This informative section also discusses the pros and cons of each deployment model.

45.7.1 mXDE Deployment Model A - Central Document Registry/Repository and Central Fine-Grained Data Source

630 In this deployment model, the health information infrastructure is designed as a centralized system, and groups an XDS Document Registry and Document Repository, and a QEDm Clinical Data Source to which fine-grained queries are directed. The operation of this deployment model is described through the transaction flows below.

635 Because of the centralized nature of the Document Registry/Repository and the Data Element (DE) Extractor and Clinical Data Source responding to QEDm queries, obtaining the Provenance information and its sharing with the Clinical Data Consumer and the Document Consumers is quite simple.

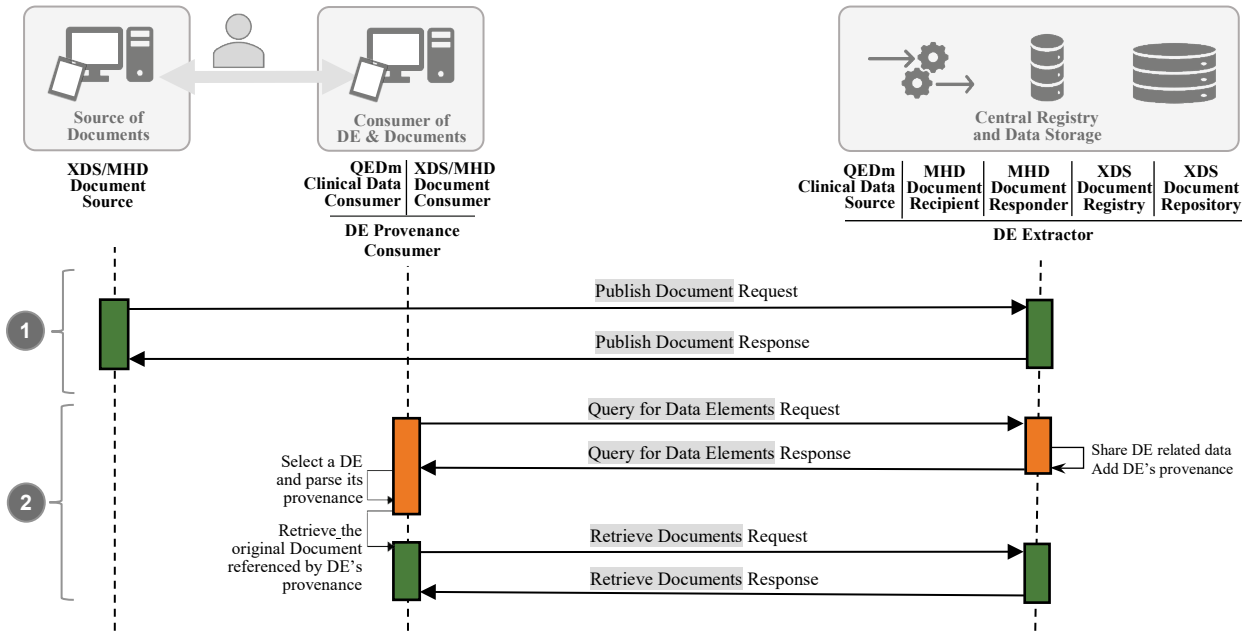

Figure 45.7.1-1: mXDE Deployment Model A

640 **45.7.2 mXDE Deployment Model B - Distributed Document Repository and Central Fine-Grained Data Source**

In this deployment model, the health information infrastructure is designed around an XDS Document Registry and a QEDm Clinical Data Source that are centralized but with multiple Document Repositories. These fine-grained queries are directed towards a centralized Clinical Data Source, but because the Document Repositories have been distributed, the centralized Clinical Data Source that can access the document content distributed among various Document Repositories and then extract data and aggregate data elements received from these documents. The operation of this deployment model is described through the transaction flows below.

645 Because of the decentralized nature of the Document Repositories, the central Data Element (DE) Extractor grouped the Clinical Data Source responding to QEDm queries have to assemble the provenance information from documents coming from various Document Repositories and consolidate this information for the Clinical Data Consumer. This deployment model is a little more complex than the previous one as the repositories are distributed, but this complexity is transparent to the Document Consumers.

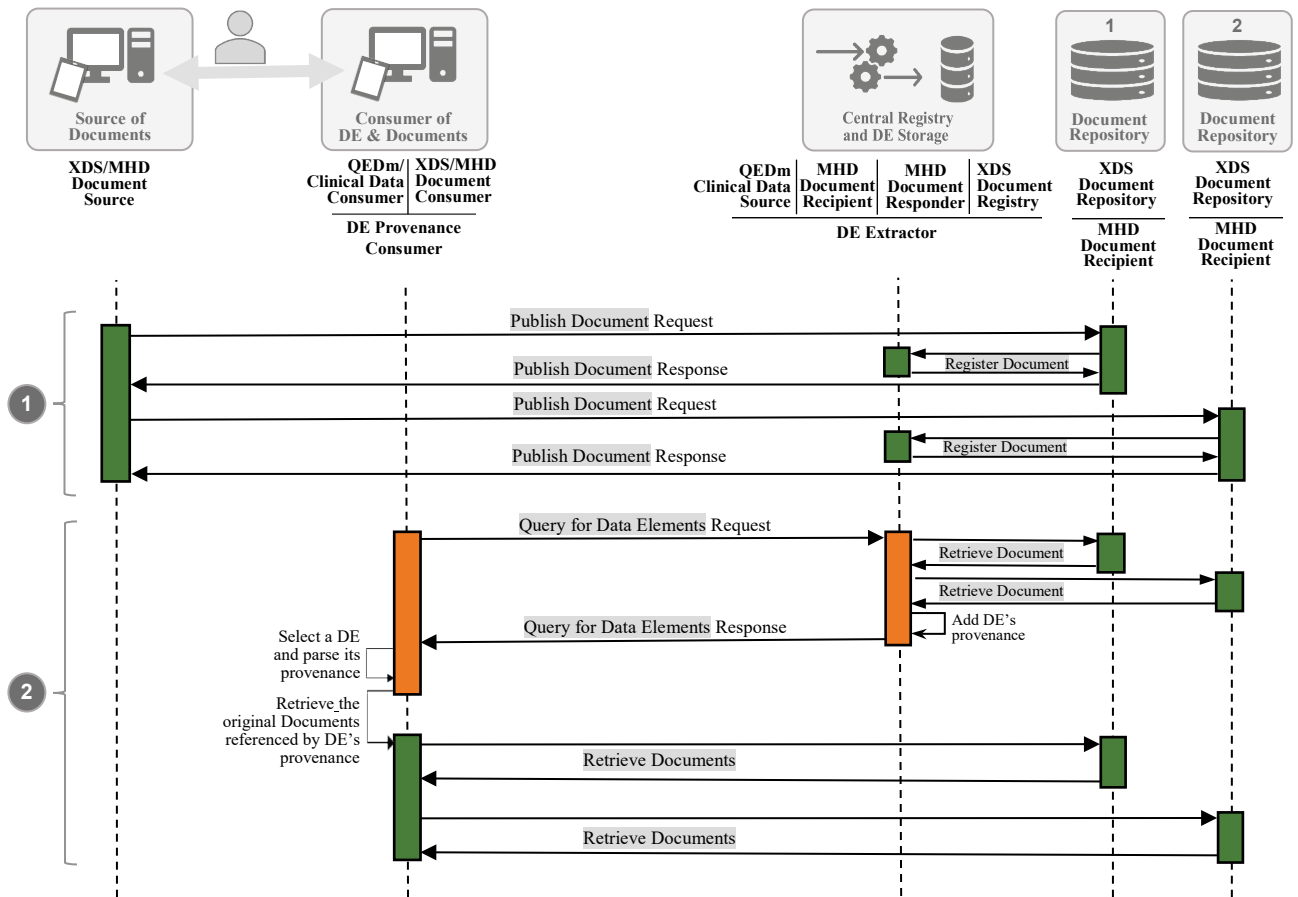

Figure 45.7.2-1: mXDE Deployment Model B

655

Volume 2 – Transactions

Update Volume 2b, Sections 3.43, 3.43.1 and 3.43.2 as follows.

3.43 Retrieve Document Set

660 This section corresponds to transaction [ITI-43] of the IHE Technical Framework. The Document Consumer, Document Repository and Initiating Gateway Actors use transaction [ITI-43].

Integration Profiles using this Transaction
Cross-Enterprise Document Sharing-b (XDS.b)
Cross-Community Access (XCA)
<u>Mobile Cross-Enterprise Document Data Element Extraction (mXDE)</u>

665 Actors that support the Asynchronous Web Services Exchange Option shall support Asynchronous Web Services Exchange on all XDS.b transactions they implement. Refer to ITI TF-2x: V.5 Synchronous and Asynchronous Web Services Exchange for an explanation of Asynchronous Web Services Exchange.

3.43.1 Scope

670 This transaction is used by the Document Consumer **or by the Data Element Extractor** to retrieve a set of documents from the Document Repository or Initiating Gateway. The Document Consumer has already obtained the XDSDocumentEntry uniqueId and the Document Repository repositoryUniqueid from the Document Registry/Initiating Gateway by means of the Registry Stored Query transaction.

675 **3.43.2 Use Case Roles**

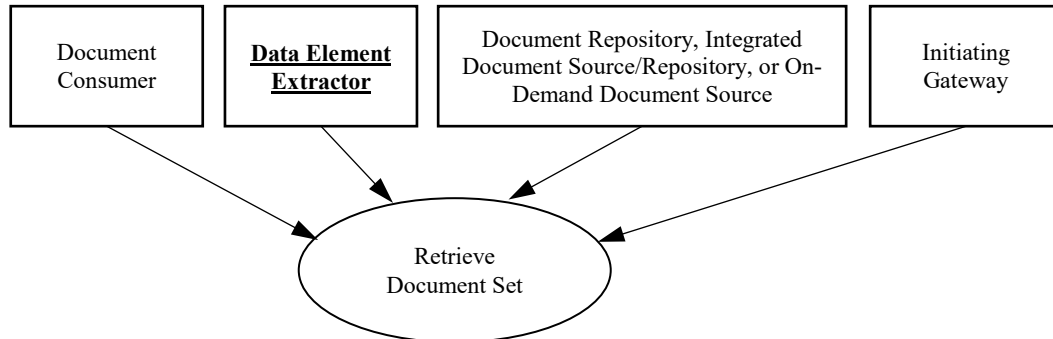

XDS Actors:

Actor: Document Consumer

Role: Obtains document.

680 **Actor:** Document Repository or Integrated Document Source/Repository

Role: Provides documents.

Actor: On-Demand Document Source

Role: Creates documents in response to a request for retrieval of an on-demand document entry.

685 Within this transaction, the Document Repository and Integrated Document Source/Repository Actors can be used interchangeably.

XCA Actors:

Actor: Initiating Gateway

690 **Role:** An Initiating Gateway which implements the XDS Affinity Domain Option retrieves a set of documents by using the Cross Gateway Retrieve transaction and/or a Retrieve Document Set transaction.

mXDE Actors:

Actor: Data Element Extractor

Role: Obtains documents.

695 **The Data Element Extractor obtains documents in the same manner as the Document Consumer does. In this transaction, the requirements for the Data Element Extractor are identical to those for the Document Consumer.**

Update Volume 2b, Sections 3.43.4 Interaction Diagram as follows.

700

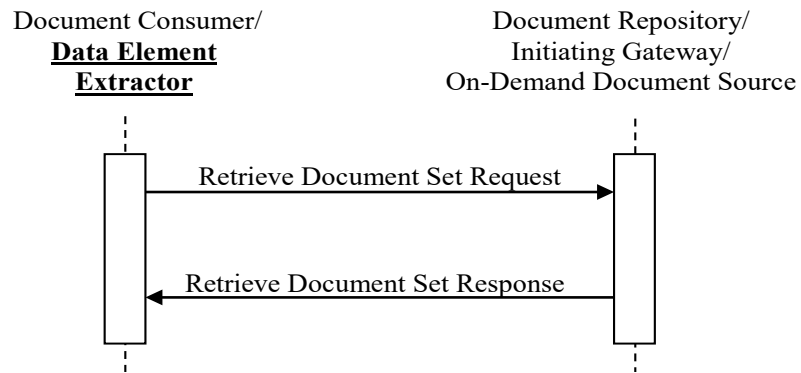

Volume 3 – Content Modules

Not applicable.